

MARTCP

Training/
Qualification
Program

Hot Mix Asphalt
Plant Technician
Level I

Aggregate Storage and
Feeding Systems

Page 4-1

1

Objectives

- Describe proper aggregate stockpiling and material-handling techniques that ensure mix quality
- Differentiate between different types of aggregate bulk stockpiling techniques
- Recognize different types of individual aggregate storage bins and feeders

Page 4-1

2

Objectives (cont.)

- Discuss differences between RAP and virgin aggregate stockpiling techniques, bins, and feeders
- Identify equipment and techniques for introducing fine bulk mineral aggregates and additives into the cold-feed area of the plant
- Describe the relationship of the previously mentioned objectives to quality mixes

page 4-2

3

Aggregate Storage and Feeding Systems

- Gradation is controlled at quarry, not at plant
- Quality management plans can identify problems

page 4-2

4

Horizontally Stockpiled Aggregate



Page 4-4

5

Horizontal Stockpiling with Separated Aggregate Piles



Page 4-5

6

Radial Stackers with Truck Dumping Station



Page 4-7

7

Bunker Storage with Rail Off-Loading System



Page 4-8

8

Belt Feeder Below Bunker Storage



9

Bunker Storage Used with Truck Delivery



10

Bulk Storage Bins

- Another approach to stockpiling aggregate
- Fed with conveyors
- Fitted with individual feeders

page 4-10

11

Large Elevated Aggregate Bulk Storage Bins

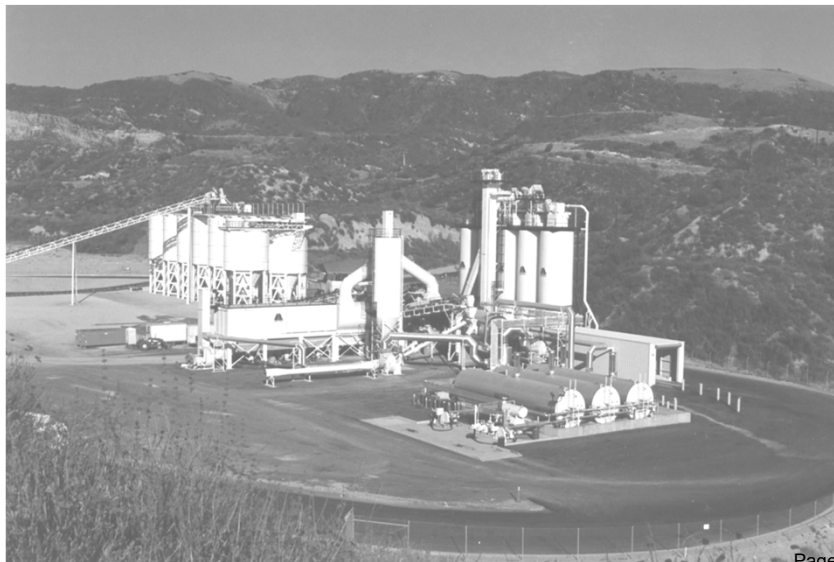

Page 4-10

12

Feeding Stockpiled Materials

- Use of loader most common
- Proper techniques required to avoid segregation

page 4-11

13

Taking Material Too Close to Grade



Page 4-12

14

Attacking Pile Straight On

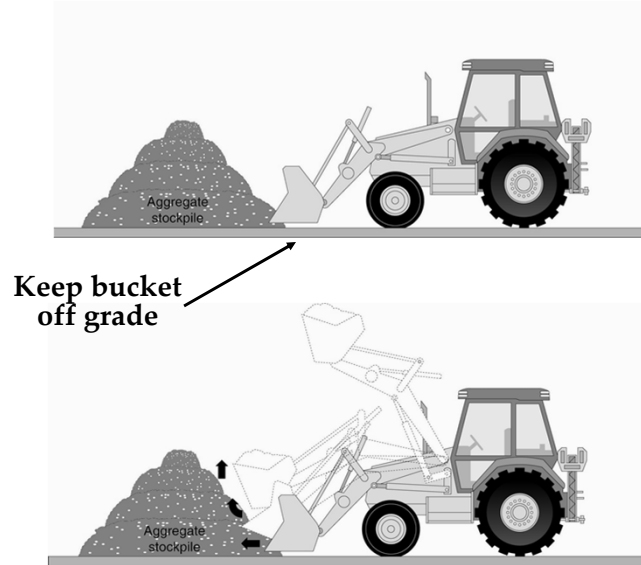

Page 4-12

15

Proper removal technique
from a stockpile created with
a radial stacker

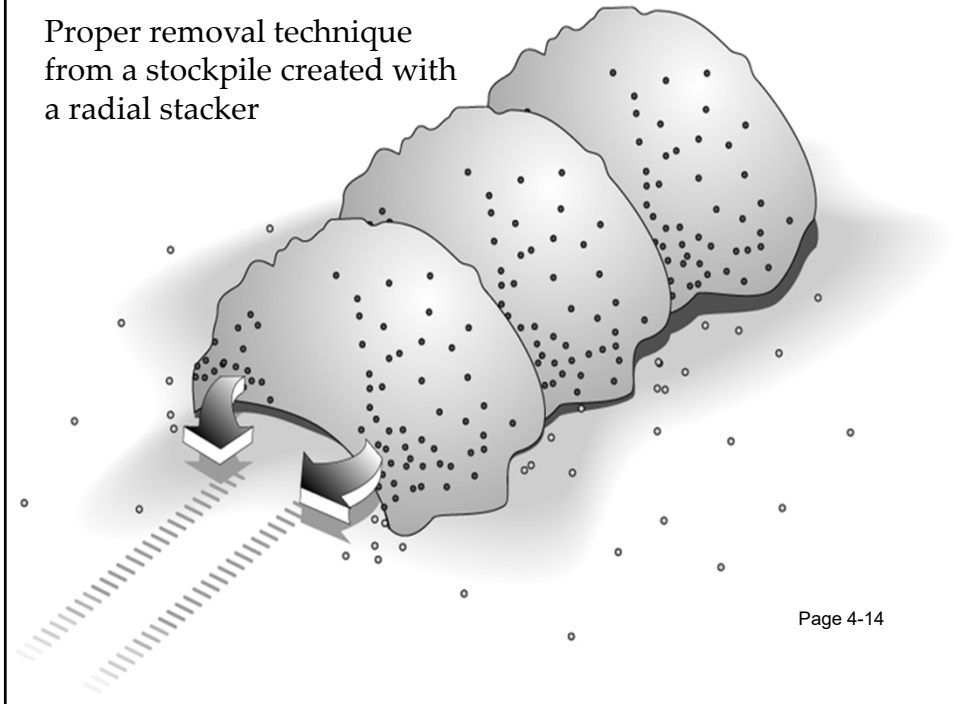

16

Cold Feed Bins with Vertical Dividers



Page 4-15

17

Material bins should
not be heaped above
divider walls



Page 4-15

18



19

RAP is a Quality Construction Material

Must be:

✓ Properly processed

✓ Properly stockpiled

Page 4-16

20

RAP Stockpile Using Radial Stacker



Page 4-16

21

Aggregate Feeders

- Recirculating plate
- Vibrating plate
- Belt Calibration

Page 4-18

22

Reciprocating Plate Feeder

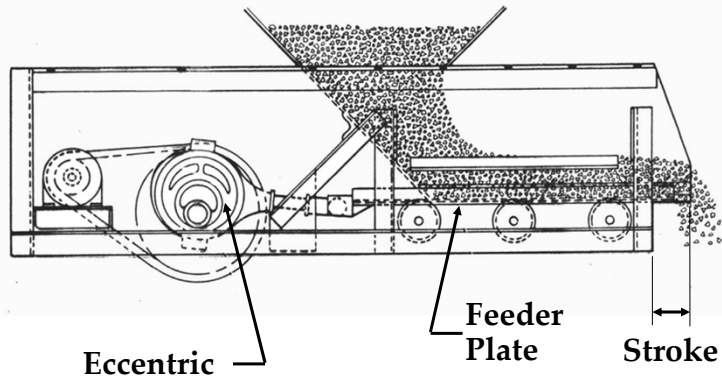

Page 4-18

23

Vibrating Pan Feeder

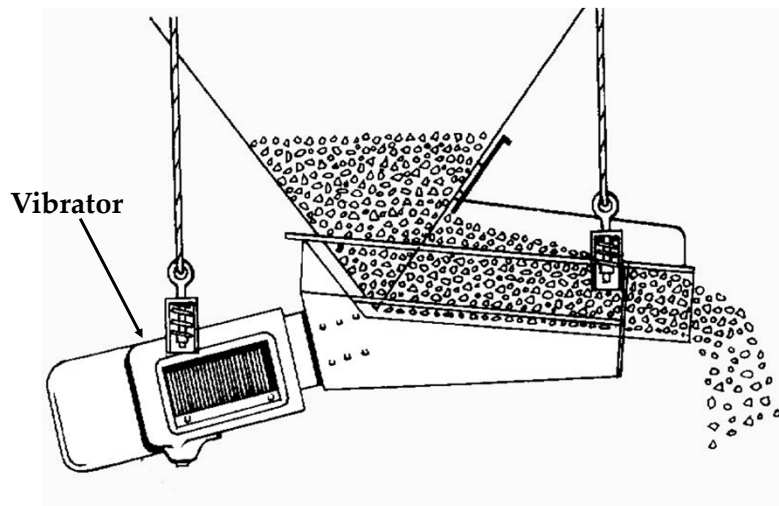

Page 4-19

24

Vibrating Pan Feeder



Page 4-20

25

Continuous Belt Feeder

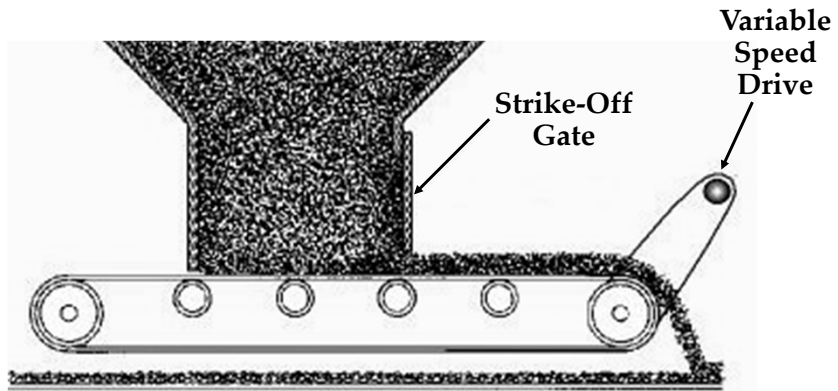

Page 4-21

26

Batch Plant with Feeder Belts on Cold Feed Bins



27

Belt Feeder and Bin Wall Vibrator



28

Effect of Bin Opening Shape on Material Flow

Rectangular
Bin Opening
Configuration

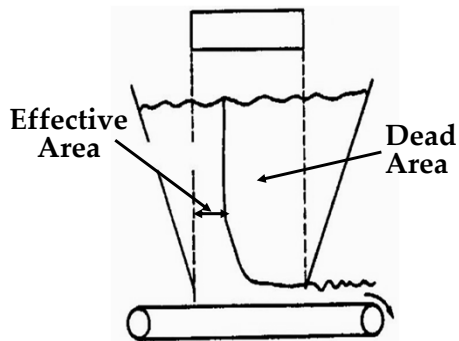

Trapezoidal
Bin Opening
Configuration

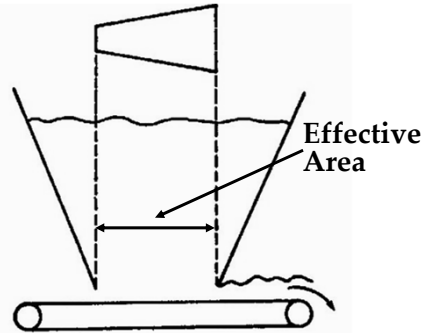

Page 4-27

29

How Material Bridges in a Bin

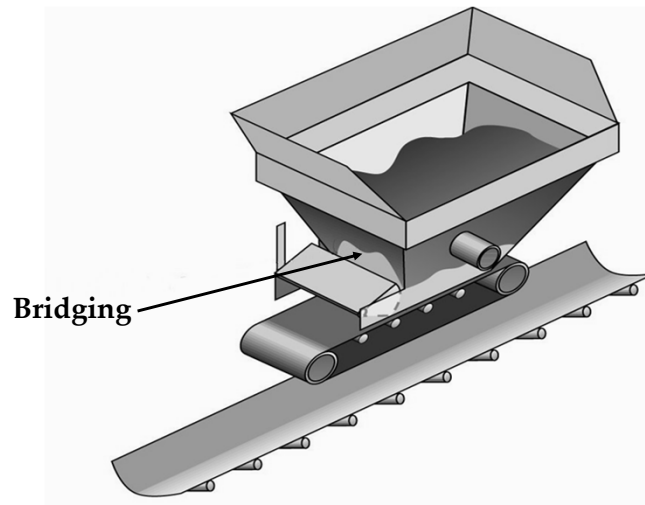

Page 4-28

30

Aggregate Feeder

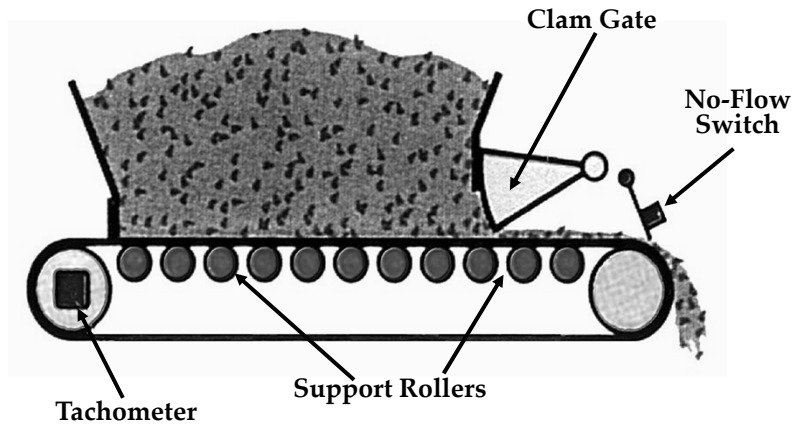

Page 4-28

31

Bin Wall Vibrators and Air Cannon on Cold Feed Bin

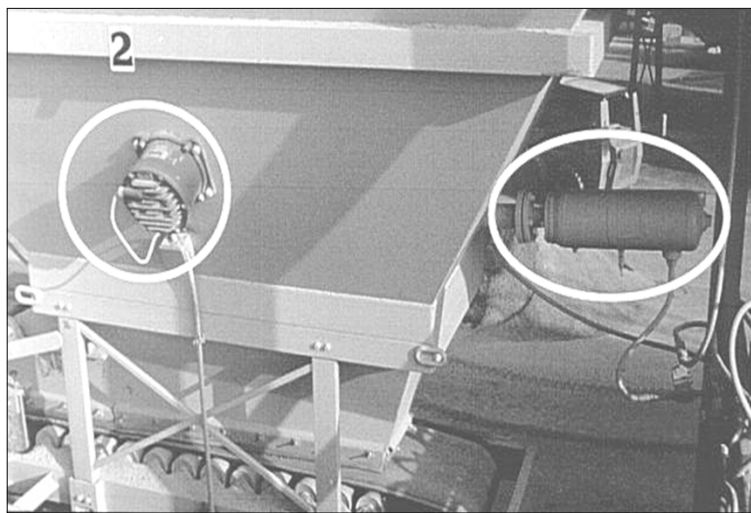

Page 4-29

32

Tachometer on Tail Shaft of Feeder

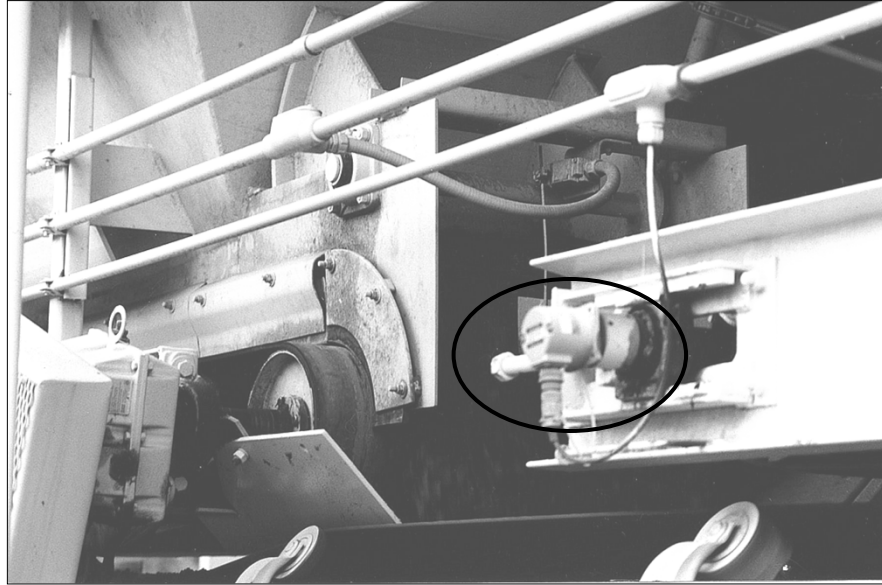

Page 4-30

33

Incline RAP Feeder



Page 4-32

34

Collecting Conveyors

Collects material from each feeder and transfers to dryer

Page 4-33

35

Collecting Conveyor Under Cold Feed Bins

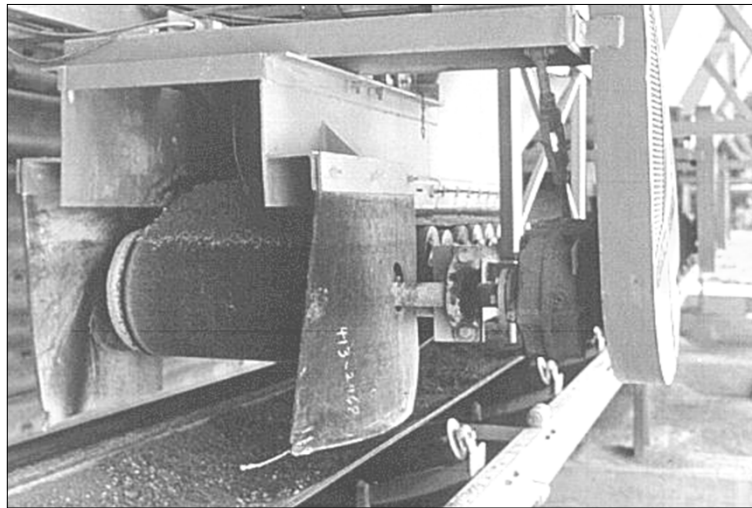

Page 4-34

36

Single Deck Scalping Screen on Drum-Mix Plant

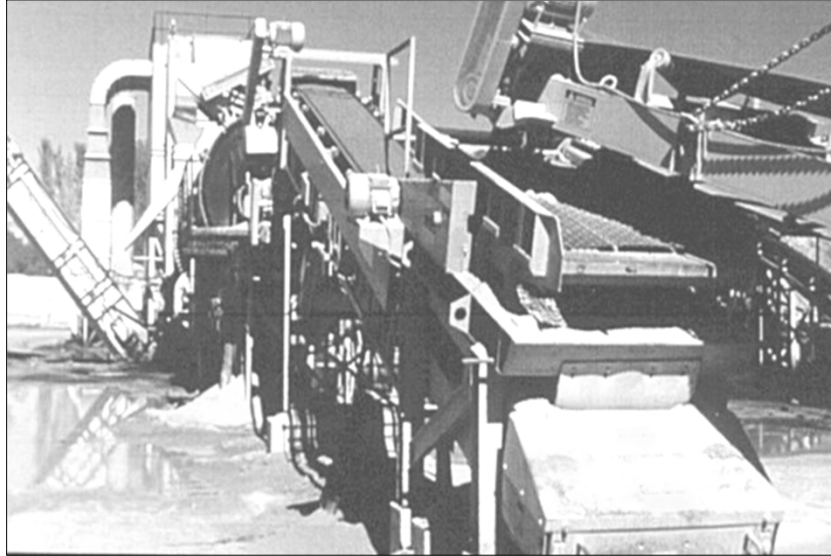

Page 4-35

37

Dust Bin at the End of a Cold Feed System



Page 4-37

38

Lime Silo Sitting over a Belt Conveyor



Page 4-37

39

Continuous Pugmill for Treating Aggregate with Lime and Coater



Page 4-38

40

Calibration

- **Each material / each component**
- **Calibrate after each run**
- **Production rates key**

41

Aggregate Sampling and Testing

- **90% to 95% of mix (aggregates)**
- **Samples must be representative**
- **Tests must be performed in accordance with established procedures**

Page 4-39

42

Sampling Principals

- **Use random sampling**
- **Use proper sampling**
- **Obtain sufficient material**

Page 4-40

43

Sampling Aggregates (AASHTO T2, ASTM D75)

- **Sample size 4 - 5 times weight required for test**
- **Sample stockpiles as being built**
- **Coarse agg. - get into stockpile**
- **Fine agg. - thief sampler**
- **Blended aggregate from belt**

Page 4-40

44

Sampling Stockpile as Being Built

- **Sample from flowing aggregate stream**
- **Entire cross section**
- **At least 3 increments**
- **Use random sampling**



Page 4-40,41

45

Sampling Stockpile as Being Built

- **Sampling from belt**
 - Stop belt (use lockout/tagout)
 - Insert 2 templates about 0.6 m apart
 - Remove material from belt
 - Obtain at least 3 increments
 - Use random sampling



Page 4-41

46

Sampling Existing Stockpile Coarse Aggregate

- Use power equipment when available
 - Knock off top
 - Create small sampling pile from materials drawn from different levels
 - Obtain at least 3 increments
 - Use random sampling



Page 4-41

47

Sampling Existing Stockpile Coarse Aggregate

- When power equipment is not available
 - Sampling from bottom, middle, and top third of volume
 - Insert board above area to be sampled
 - Use random sampling



Page 4-41

48

Test Repeatability and Reproducibility

- All procedures have some testing error
 - Conduct tests as written
 - QC and QA testing has to be done using the same procedures

49

Routine Aggregate Tests

- √ Moisture content of aggregates
- √ Aggregate gradation
- √ Specific Gravity & Absorption of Aggregates

Page 4-42

50

Aggregate Sampling and Testing Summary

- Use Random Sampling
- Sample in Accordance with Established Procedures
- Test in Accordance with Established Procedures
- DO NOT TAKE SHORTCUTS



51

QUESTIONS ?



52

MODULE 3

AGGREGATE STORAGE AND FEEDING SYSTEMS

Glossary of Keywords

Bulk Storage Bin	A large cold-feed bin system that allows large quantities of individual aggregate to be stored directly over the hopper and feeder.
Bunker	Type of aggregate storage system in which large quantities of individual aggregate can be stored between common walls.
Cold Feed	A common field term used to denote the entire cold aggregate feed end of the hot-mix plant facility, regardless of style.
Cold-Feed Bin	The (typically) steel bin that holds quantities of an individual aggregate for metering to the hot-mix plant. Typically this bin is charged with a front-end loader.
Feeder	The common term for the device that sits immediately below the hopper of the cold-feed bin and is used to meter aggregate to the dryer.
Mineral Filler	A common generic term for fine, mineral aggregate products such as lime and different types of filler materials. Typically, most of the material will pass through a 0.075 mm (No. 200) mesh screen.
Radial Stacker	Type of conveyor and stockpiling system that allows aggregate to be stockpiled at height with a conveyor that moves on an arc.
RAP	Reclaimed Asphalt Pavement is hot-mix asphalt pavement that has been removed from the field and stored for processing into new hot-mix asphalt.
Scalping Screen	A screen used in drum-mix plants to remove oversized aggregate, and tramp materials from aggregate, prior to introduction into the drum-mix dryer.
Stockpiling	The process of storing aggregate in large quantities for future use.

3.1 INTRODUCTION

In today's hot-mix plants, the gradation and quality of the aggregate is assured at the quarry, not at the hot plant. The purpose of the hot-mix plant is to meter and blend the individual aggregates to the proper final composite gradation. Because of this, it is important that material characteristics are periodically verified with test procedures applicable to the agency or customer for whom the mix is being produced. The automated controls and plant equipment cannot detect or correct inconsistencies in gradation or aggregate quality. This is especially true with drum-mix plant facilities, where there is not a chance for even slight gradation correction.

If individual aggregate gradation is suspect, then a batch-type plant may be indicated for production. However, batching plants, with sizing screens over the hot bins, can control gradation only within certain limits. The best field approach is to not use aggregates with suspected gradation inconsistency. These aggregates can be rescreened and regraded, or recrushed and resized. In short, if materials have inconsistent gradation, it is an aggregate production issue, not a hot-mix production issue.

Ultimately, it is the responsibility of the hot-mix producer to provide a quality product. If plant operators or quality control managers suspect problems with aggregate quality or gradation consistency, they are obligated to cease production, investigate, and seek a solution to the problem.

It should be reiterated here that the automated controls and plant equipment cannot detect or correct inconsistencies in gradation or aggregate quality. Plant equipment is designed only to meter and measure the given materials to a specified formula accurately and consistently -- then thoroughly heat, thoroughly coat, and safely store the final hot-mix product for dispatch to the job site. There are, management practices and equipment choices available to the producer to ensure that the aggregate is properly stored, protected, and introduced into the plant.

3.2 STOCKPILING AGGREGATES

When stockpiling aggregates, a producer has several choices available.

Horizontal Stockpiling

As shown in figure 3.1 horizontal stockpiling with end-dump aggregate trailers is probably the most commonly used method for stockpiling materials at a hot-mix plant.



Figure 3.1 Horizontally stockpiled aggregate.

When stockpiling with end-dump trailers, each truckload should be dumped in an individual pile as shown in figure 3.2. Any procedure that results in the aggregate being pushed or dumped over the side of the stockpile should be avoided because such a practice may result in segregation. Segregation is the separation of the larger aggregates from the smaller aggregates, a condition that destroys the uniformity of the mix.



Figure 3.2 Horizontally stockpiling with properly separated aggregate piles.

Trucks and loaders should also be kept off the stockpiles because they break aggregate, create fines, and contaminate the stockpile. Keeping them off is often easier said than done, and drivers and equipment operators must be educated as to why they need to minimize their contact with the aggregate. Figure 3.3 displays horizontal stockpiles.



Figure 3.3 Horizontal stockpiles.

Stockpiles must be stored separately in the yard and should not touch. This eliminates any possibility that materials could contaminate an adjacent pile. Materials should be stockpiled on a clean, free-draining grade to allow any precipitation that might accumulate in the materials to leave. To minimize concern in this area, many contractors pave under the aggregate stockpiles which accomplishes the following:

- Eliminates any possibility that yard stone or yard materials can contaminate the stockpile.
- Reduces moisture in aggregate stockpiles by guaranteeing a solid, free-draining base. This is critical because reduced moisture lowers drying costs and maximizes plant production.
- Reduces fugitive dust emissions that are generated in the process of taking aggregates from stockpiles and charging cold-feed bins.

Producers also protect the aggregate by stockpiling under a roof as shown in figure 3.4. This prevents precipitation from accumulating in the aggregate. Protected aggregates are easier to handle, are less expensive to dry, and allow the plant to achieve design production rates. Covered stockpiles must allow for free airflow to avoid moisture buildup.



Figure 3.4 Covered aggregate stockpiles.

Radial Stacking Conveyors

Radial stacking conveyors are another approach used to stockpile aggregates as shown in figure 3.5. They allow more material to be stockpiled over a smaller area by raising the elevation of the stockpile and reducing truck traffic in the yard. Radial stackers can be used at the end of truck dumping stations or at the end of rail car off-loading conveyors as shown in figure 3.6.



Figure 3.5 Radial stackers at quarry facility.



Figure 3.6 Radial stackers with truck dumping station.

Proper use of a radial stacker includes slowly raising the conveyor that allows the stockpile to grow vertically after the conveyor has been moved horizontally. This approach reduces the segregation from stockpiling that can occur as a stacker is allowed to drop aggregate from a great height on horizontal moves. The recommended maximum drop to avoid segregation is 2.4 m.

As with horizontal stockpiling, paving under the aggregate piles reduces fugitive dust emissions, aids in draining the stockpile from free moisture, and protects against contamination of materials from yard stone.

Bunker Storage Systems

Bunker storage systems are often used in conjunction with rail off-loading facilities or truck dumping stations when radial stacking systems are not employed as shown in figure 3.7. Bunker storage systems typically use transfer conveyors from the unloading site to the bunkers. Frequently an indexing conveyor is employed to direct the aggregates to the proper bunker.



Figure 3.7 Bunker storage with rail off-leading system.

Bunker systems offer several advantages over stockpiling materials in the open:

- They allow larger quantities of materials to be stockpiled over a relatively small footprint because materials can be stockpiled up against the bunker walls and raised vertically.
- They can be easily covered to reduce moisture accumulation from precipitation, thus reducing operating costs.
- They reduce any possibility of material contamination between piles. Material must not be allowed to overflow or extend beyond the end of the bunker wall. Bunker systems can also be built over a tunnel that houses the individual aggregate feeder belt conveyors as shown in figure 3.8, so the plant can be fed without moving the aggregate with a loader.



Figure 3.8 Belt feeder below bunker storage.

Bunker systems eliminate a coordination point for smooth production -- assuring that cold-feed materials are being introduced to the plant at a proper feed rate for drying and mixing.

Bunker systems can be fed directly from a quarry as shown in figure 3.9, further reducing operating costs by eliminating haul costs to the plant site. Production management at the quarry can direct materials to the hot plant when inventories are depleted.



Figure 3.9 Bunker storage used with truck delivery.

Bulk Storage Bins

Bulk storage bins are another approach to stockpiling aggregate materials. They are typically fed with a charging conveyor from a truck dumping station or a rail off-loading facility as shown in figure 3.10. Bulk storage bins are different from bunker systems in that the bins are structural steel and have the individual feeder belts fitted to the bottom of the bins. Essentially, they look like giant cold-feed bins.



Figure 3.10 Covered and elevated bulk storage bins.



Figure 3.11 Bulk storage bins used with truck dumping system

Hot-mix plants are moving in the direction of bulk storage bins for the following reasons:

- Reduced variable costs in production because materials do not have to be moved again with a front-end loader.
- Reduced fugitive dust emissions associated with tramming materials with a front-end loader over haul roads.
- Reduced acreage required to stockpile large quantities of material.

Bulk storage bins can be easily covered to keep precipitation from accumulating in the materials. Covers help prevent materials from freezing in the winter and help reduce operating costs by lowering drying expenses and maximizing production.

3.3 FEEDING STOCKPILED MATERIALS INTO COLD-FEED BINS

When stockpiling techniques require feeding stockpiled materials into cold-feed bins, care should be taken to use the following management practices:

- Material should first be fed from the mid-section of the pile, and not from the bottom of the pile. This prevents the wetter aggregate, which increases drying costs and reduces production throughput, from being fed into the dryer.
- Material should not be obtained close to the grade as shown in figure 3.12, as this allows the possibility of contaminating the aggregate with material from the grade.
- Material should be removed from the face exposed to the sun as this side of the pile will have less moisture. Use the solar effect to help reduce drying costs and increase dryer throughput.
- If material has been stockpiled in "lifts," remove the material so as to split a horizontal seam, rotating and lifting up with the bucket. This helps remix the aggregate and reduces any tendency towards segregation of material that might have occurred. The entire "face" should be worked in order to minimize any segregation that might have occurred due to stockpiling techniques.
- Remove material with a front-end loader by going straight into the stockpile, rotating the bucket up, then backing straight out instead of scooping up through the pile as shown in figure 3.13. This will minimize segregation that can be caused by larger-size aggregate rolling down the face of the pile.



Figure 3.12 Improper removal technique with loader.

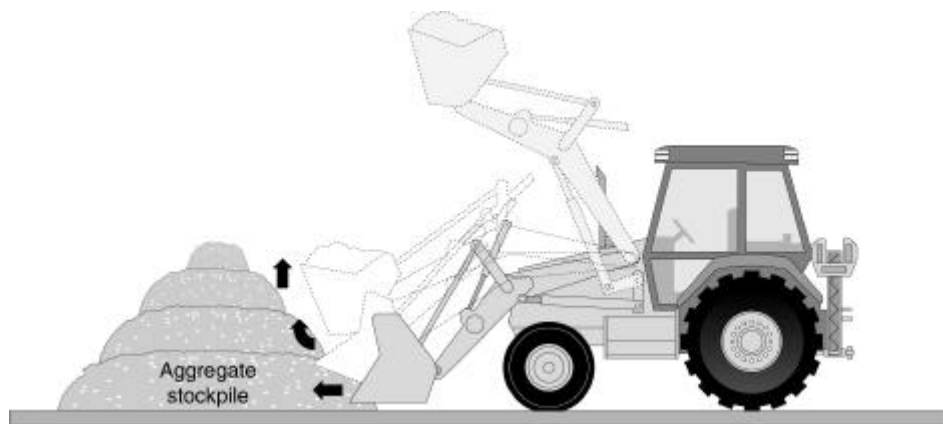
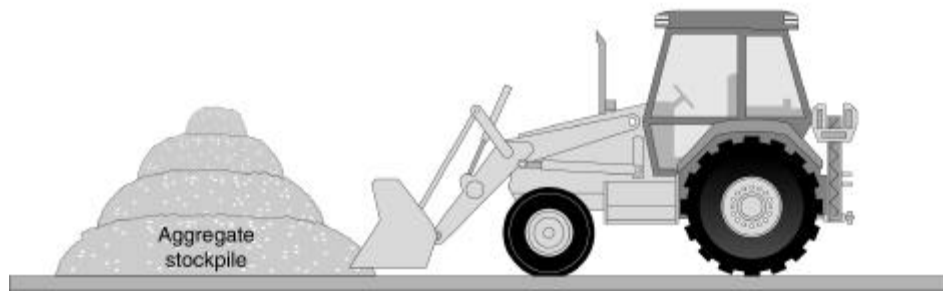

Figure 3.13 Proper removal technique with loader.

In all cases, the loader operator should try to work a vertical face, lifting up and through the face. The operator should not take material from the same point repeatedly, allowing aggregate to fall down and fill the void left behind. Following these guidelines reduces the possibility of larger aggregate rolling down the slope and segregating in the process.

When removing materials from a stockpile that has been created with a radial stacker, materials should be taken from the end of the stockpile and from the cross section as shown in figure 3.14. Materials should never be removed from the sides of the pile. The outsides of the pile will naturally be coarser than the middle and inside of the pile. The front-end loader should take some material from each side and the middle, and fold this material into the middle so that is thoroughly mixed as shown in figure 3.15.

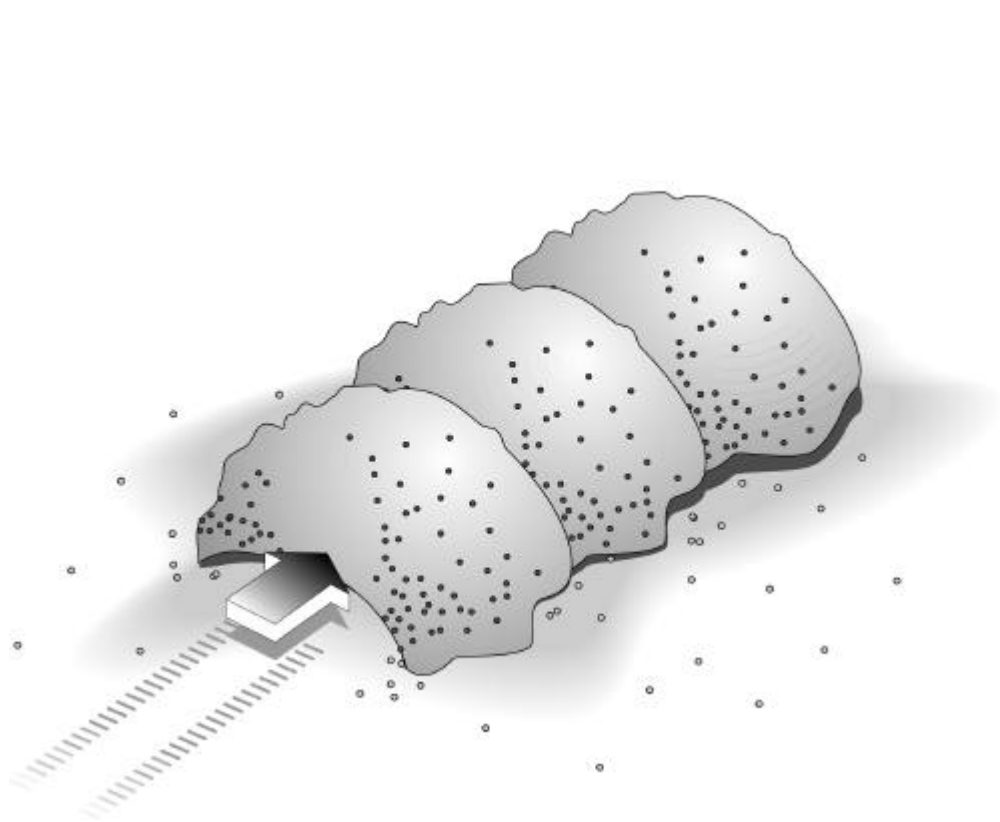

Figure 3.14 Remove material from end of stockpile created with radial stackers.

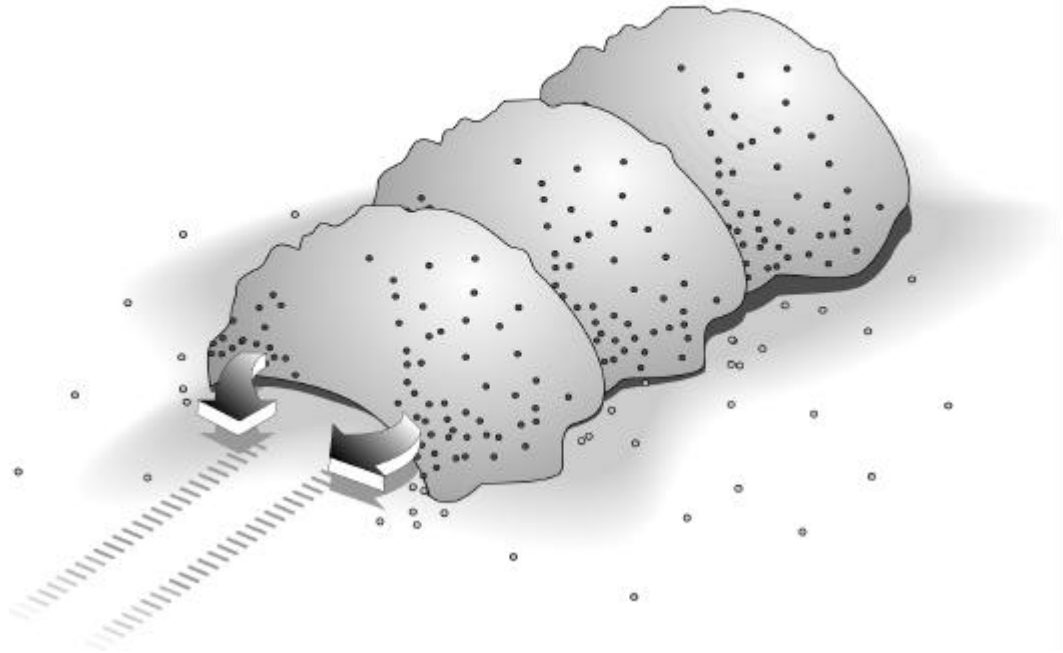

Figure 3.15 Mix material from wings with center material when removing aggregate.

Paving haul-road surfaces and slowing equipment speeds will help reduce the fugitive dust emissions that can occur from tramming aggregate to cold-feed bins with a loader.

Discharge aggregates from the loader to the cold-feed bin in a slow, even movement and at an elevation relatively low to the feed bin to help reduce the possibility of fugitive dust emissions while charging the bin.

Cold-feed bins should not be overcharged or heaped to the point where it is possible that materials from one bin can flow over to the adjacent bin as shown in figure 3.16. The loader bucket width must be less than the width of the bin. Vertical dividers, as shown in figure 3.17, can be placed between the bins to make sure that overflow cannot occur, even when bins are filled to capacity. These bin dividers should not be installed on the side on which the loader feeds the bin.



Figure 3.16 Material should not be heaped causing overflow.

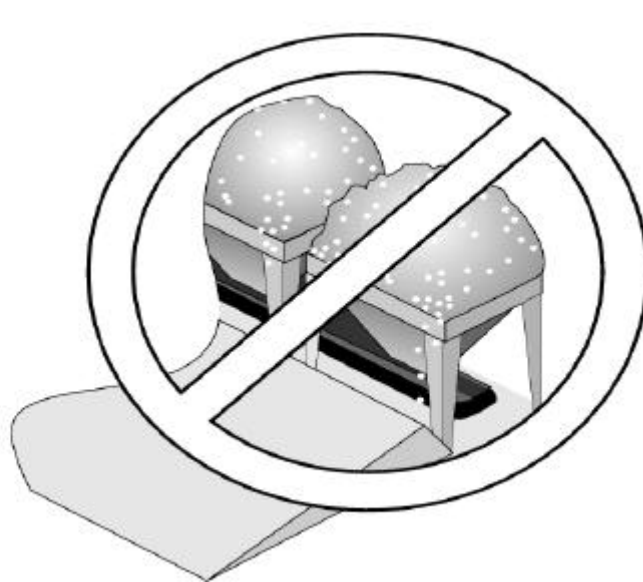

Figure 3.17 Cold feed bins with vertical dividers.

3.4 STOCKPILING RAP MATERIALS

RAP, or Reclaimed Asphalt Pavement, materials deserve special attention, as they have unique properties and unique stockpiling requirements. RAP materials have two separate gradation characteristics.

From a mix-design standpoint, the composite stone gradation in the RAP, asphalt content and asphalt properties are important. From this information a recycled job-mix formula is constructed.

From a material-handling standpoint, the gradation of the RAP particles is important. This is a separate issue from the gradation of the aggregate in the RAP and is often a point of confusion. The easiest way to remember this is to realize that a 50 mm RAP particle may not have an aggregate size in it any larger than 12.5 mm -- and the size of the RAP particle has nothing to do with the mix formula that is being made with it.

Because RAP often has 50 mm size material, it can easily segregate when stockpiled from an extreme height. When using radial stackers, RAP should be stockpiled very carefully. Older literature, manuals, and "rules of thumb" suggest that RAP materials should not be stacked with radial type stackers but placed along the ground at truck/trailer discharge height or no higher than what a loader could lift. It was believed that RAP material would recompact with its own weight, and radial stacking was discouraged.

However, years of field experience have shown that RAP materials have a tendency to "crust over" only in the first 152-254 mm exposed to atmosphere. They do not seem to compact inside the pile. Therefore, careful radial stacking is acceptable as shown in figure 3.18, and the loader can easily feed the RAP materials once it breaks through the crust with the bucket. In fact, because of the crust phenomenon, many producers now discourage horizontal stockpiling. In a horizontal stockpile the loader operator constantly encounters this crust, making removal of the pile difficult and reducing plant production rates.

A unique aspect of RAP is that it does not easily drain water and accumulated moisture has a tendency to stay in the pile. This is another reason why producers have shifted toward radial stacking of RAP materials. The crust formed in radial stacking has a tendency to seal the pile and helps reduce moisture penetration.



Figure 3.18 RAP stockpile using radial stack.

In fact, low-level horizontal stockpiles, when left through the winter in climates with heavy snowfall, are extremely wet in the spring and difficult to handle. This reduces plant output because of the handling characteristics, and the high moisture content. There is an increase in production costs because of the large quantity of fuel required to dry out the moisture.

Some producers have invested in open-sided covered buildings for stockpiling RAP as shown in figure 3.19 to minimize the negative effects of moisture getting in the pile. If large quantities of RAP are used, an investment in this type of storage unit can have a positive payback in reduced fuel consumption and increased plant production.



Figure 3.19 Covered RAP stockpile.

If crushing equipment is available and space allows, any additional crushing or downsizing of the RAP is best done just prior to production. There is less chance for moisture to enter and stay in the RAP material if it is crushed just prior to use. Producers that have on-site crushing and screening equipment for RAP typically try to stay only a week or two ahead of hot-mix production.

If large quantities of RAP are available from one source and that source is consistent, then it is advisable to stockpile this RAP separate from other RAP materials. This pile can be randomly sampled and mix formulas constructed specifically for this RAP source.

If various sources of RAP have to be mixed together at the plant site, due to space constraints or to the lack of significant volume coming from each RAP source, it is advisable that the RAP be processed by crushing and screening. Random samples should be taken and tested to determine the characteristics of the final RAP product. Field experience has proven that a consistent RAP product can be made from a stockpile of RAP taken from different sources.

Typically the RAP is mixed with a dozer or front-end loader, assuring that as much blending as possible occurs with this equipment. Then the crushing equipment is adjusted so that the RAP product is reduced in size to the top size of largest aggregate desired. Frequently, some downsizing of the largest aggregate occurs. For example, RAP is crushed to 19 mm minus, with the knowledge that some, but not all, of the RAP has 25 mm aggregate in it. In this way, the producer can be sure that all RAP will be uniformly sized at 19 mm minus.

Frequently the producer makes two products, a nominal 19 mm x 12.5 mm product, and a 12.5 mm minus product. It is not unusual to find material passing a 4.75 mm (No. 4) sieve rejected in an effort to remove unwanted dirt or subgrade materials. Common practice will vary slightly from region to region with specifying owner/agencies often drafting acceptable procedures for the area. However, RAP blended, crushed, and sized through a crushing and screening plant in the above manner is typically discharged into stockpiles in a uniform product, however, and this fact requires special note in the course.

3.5 TYPES OF AGGREGATE FEEDERS

In both batching facilities and drum-mix facilities, aggregate feeders are employed to regulate the flow of each individual material into the hot-mix plant, regardless of the types of aggregate stockpiling techniques and aggregate storage equipment used. Although all new plants are being built with belt feeders, several different types of feeders have been used in the past. Some of these are still in use today, so they merit discussion.

Reciprocating Plate Feeders

Reciprocating plate feeders are older-style feeders and were used only in conjunction with batch plants, and originated in the quarrying industry.

Reciprocating plate feeders operate with a drive motor and cam fitted to a solid plate as shown in figure 3.20. The motor and cam cause the plate to move back and forth, which shakes material from the feed bin. This type of feeder is no longer manufactured and hasn't been made since the 1960s. Occasionally, however, you will stumble on a batch plant with this style of feeders. If you do, take a photograph for posterity. It should be obvious they can't be used for a drum-mixer since they cannot regulate flow accurately.

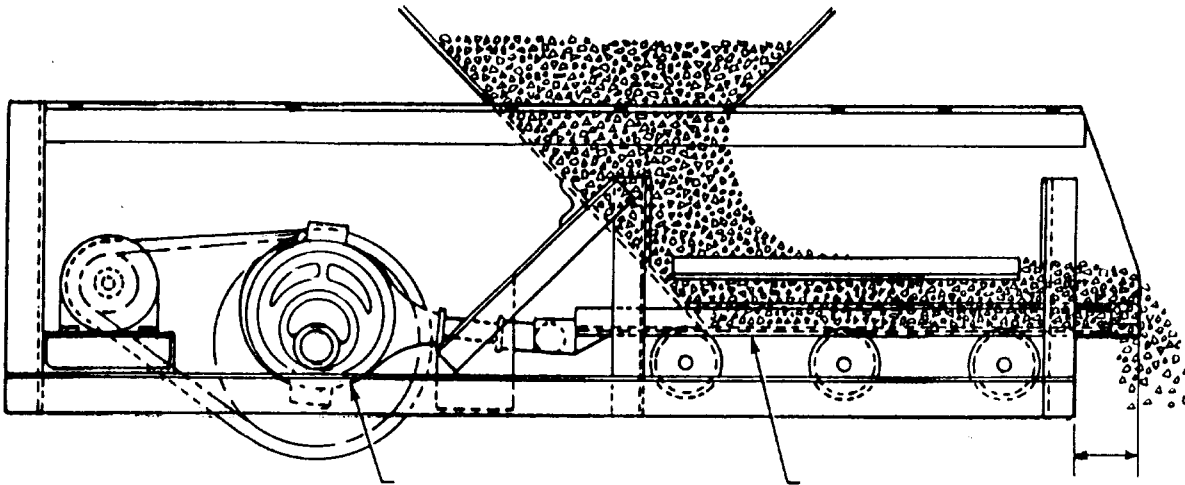

Figure 3.20 Reciprocating plate feeder.

Vibrating Pan Feeders

As time passed, vibrating pan feeders became more common in batch-style plants. If a batch-style plant is not equipped with belt feeders, odds are that it has vibrating pan feeders. These are still very common today.

Vibrating pan feeders are superior to reciprocating plate feeders because they can be regulated for better flow and the feed mechanism is less complicated.

With a vibrating pan feeder as shown in figure 3.21, a vibrating motor mechanism is located at the rear of the pan. The frequency of this motor can be changed with a controller card and rheostat in the control house. More vibration means more flow; less vibration means less flow. Vibrating pan feeders are not accurate enough in the flow control to be used for drum-mixer plants that control gradation at the cold feed and are only used in a batch-style plant. With the control panel, the operator can adjust the flow from each material bin to match the batching cycle of the tower.

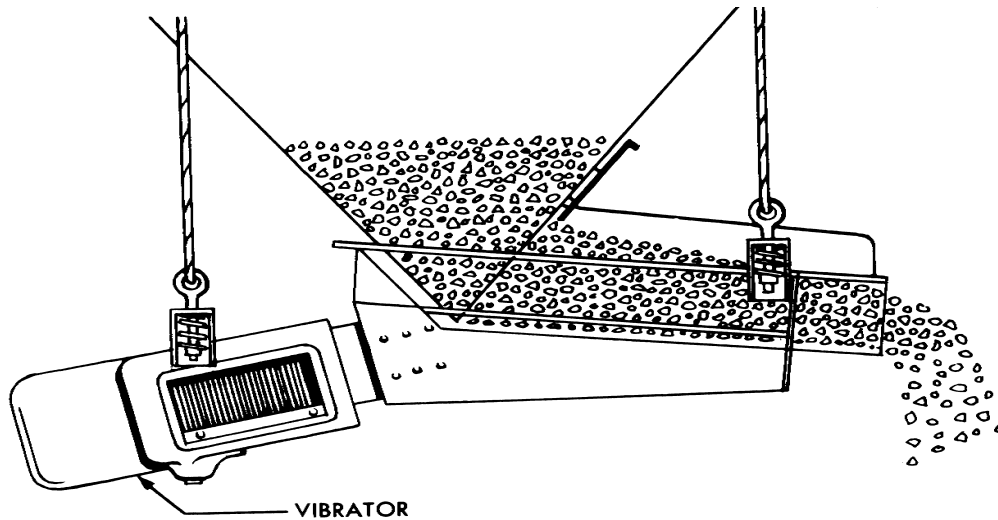

Figure 3.21 Vibrating pan feeder.

In most cases, the aggregate sizes being charged into the cold-feed material bins, or in the cold-feed material bunkers, match the sizing screens in the batch tower and, consequently, the materials in the hot bins. The job of batch plant operators, then, is to match the cold-feed flow to the hot-bin flow. This is done by observing the hot-bin level indicators in the batch tower, the batch production, and the feed level from the cold-feed material bins. If they run over on one material, they reduce the cold-feed flow of that material or the individual materials that make up that hot-bin pull. If they run short of material, they increase the cold-feed flow of that material or the individual materials that make up that hot-bin pull. Figure 3.22 shows an actual vibrating pan feeder.



Figure 3.22 Vibrating pan feeder.

The control rheostats and vibration controls that are attached to each vibrating pan are used to regulate that cold feed flow. Frequently, a total flow control rheostat or potentiometer is available that increases or decreases the flow of all aggregate materials to the tower. This is used when the balance of the individual feeds is correct, but the operator wants to speed up or slow down batch production.

Belt Feeders

Belt feeders became the primary feeder after continuous-flow plants became popular. The flow of the individual feeder can be accurately controlled with a belt feeder.

Belt feeders, as shown in figure 3.23, have flow control available in two ways: gate opening and belt speed. Belt feeders are very stable and predictable in the flow of aggregate, as long as the opening to the feeder is not restricted.

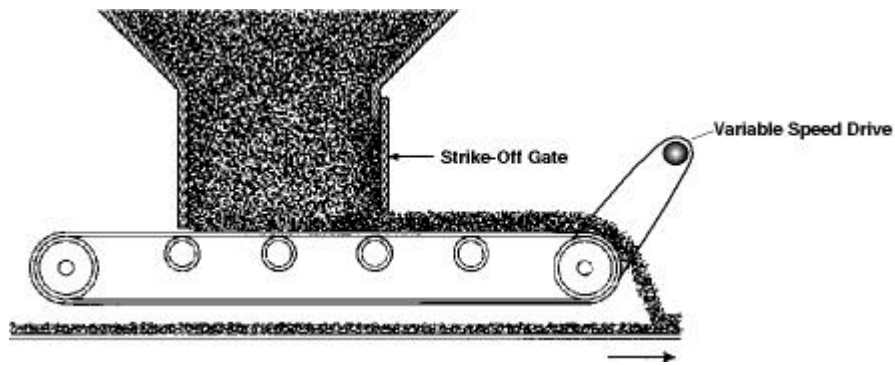

Figure 3.23 Continuous belt feeder.

Belt feeders are used exclusively on drum-mix plants as shown in figure 3.24. For a discussion of how the feeder is actually used to meter aggregate and control gradation on a drum-mixer.



Figure 3.24 Drum-mixer with feeder belts on cold feed bins.

Belt feeders have become popular even for batch-style plants as shown in figure 3.25. New batch plants are now shipped with belt feeders, not vibrating pan feeders. Many batch plants are also being converted from vibrating pan feeders to belt feeders because they regulate the flow of material better. They also allow the possibility for cold-feed proportioning to be done at the feeder and bypassing screens for gradation control in states that allow this type of operation.



Figure 3.25 Batch plant with feeder belts on cold feed bins.

For a batch plant, the flow from the individual feeders can be regulated with the strike-off gate as shown in figure 3.26. Batch plants do not require variable-speed motor/controllers to be fitted to the drive pulley.

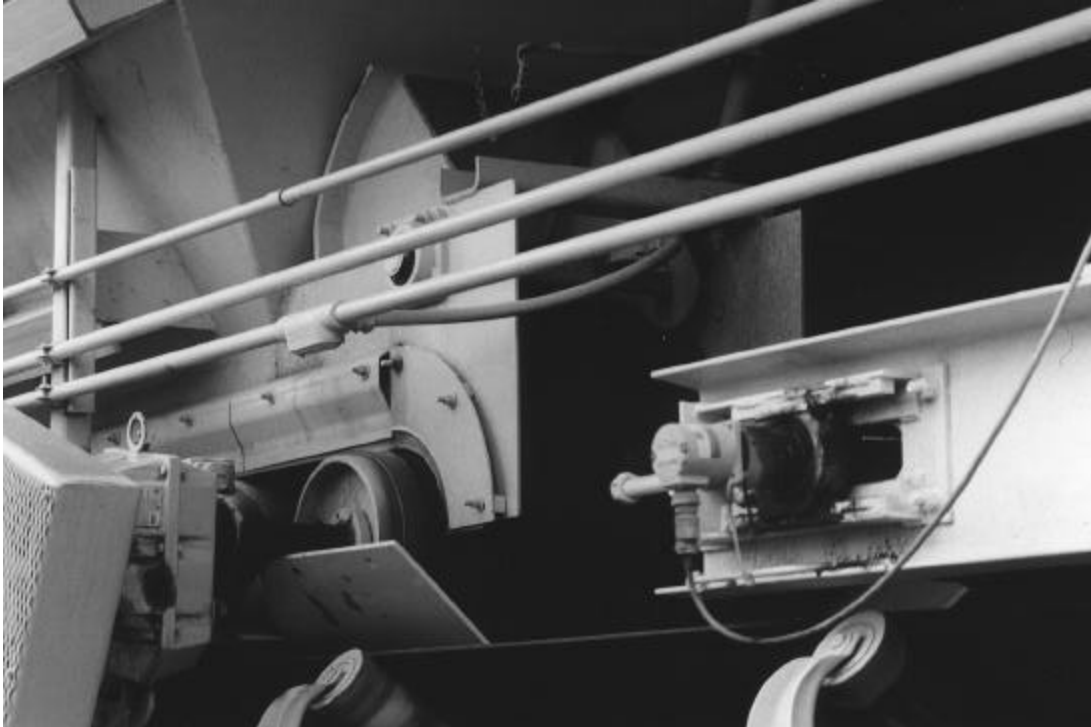

Figure 3.26 Belt feeder with adjustable strike-off gate.

Adjustment of the strike-off gate to increase or decrease flow is sufficient to regulate the cold-feed flow to approximate the hot-bin draw in a batch plant. This is generally insufficient for production with a drum-mix plant, although it is theoretically possible. Of course, walking out to the feeder and changing the gate setting is very inconvenient.

For this reason, and because many states allow screenless mixing in a batch plant with drum-mix style gradation control at the cold feed, many batch plants are now equipped with variable-speed belt feeders.

Types of Variable-Speed Belt Drives

There are several styles of variable-speed drives for belt feeders, but most feeders in the hot-mix industry fit into one of the following categories:

- DC motor with variable-speed motor controller card fitted to a constant-speed gearbox as shown in figure 3.27.



Figure 3.27 Feeder with DC motor and constant speed gearbox.

- AC motor with variable-speed motor controller card fitted to a constant-speed gearbox as shown in figure 3.28.

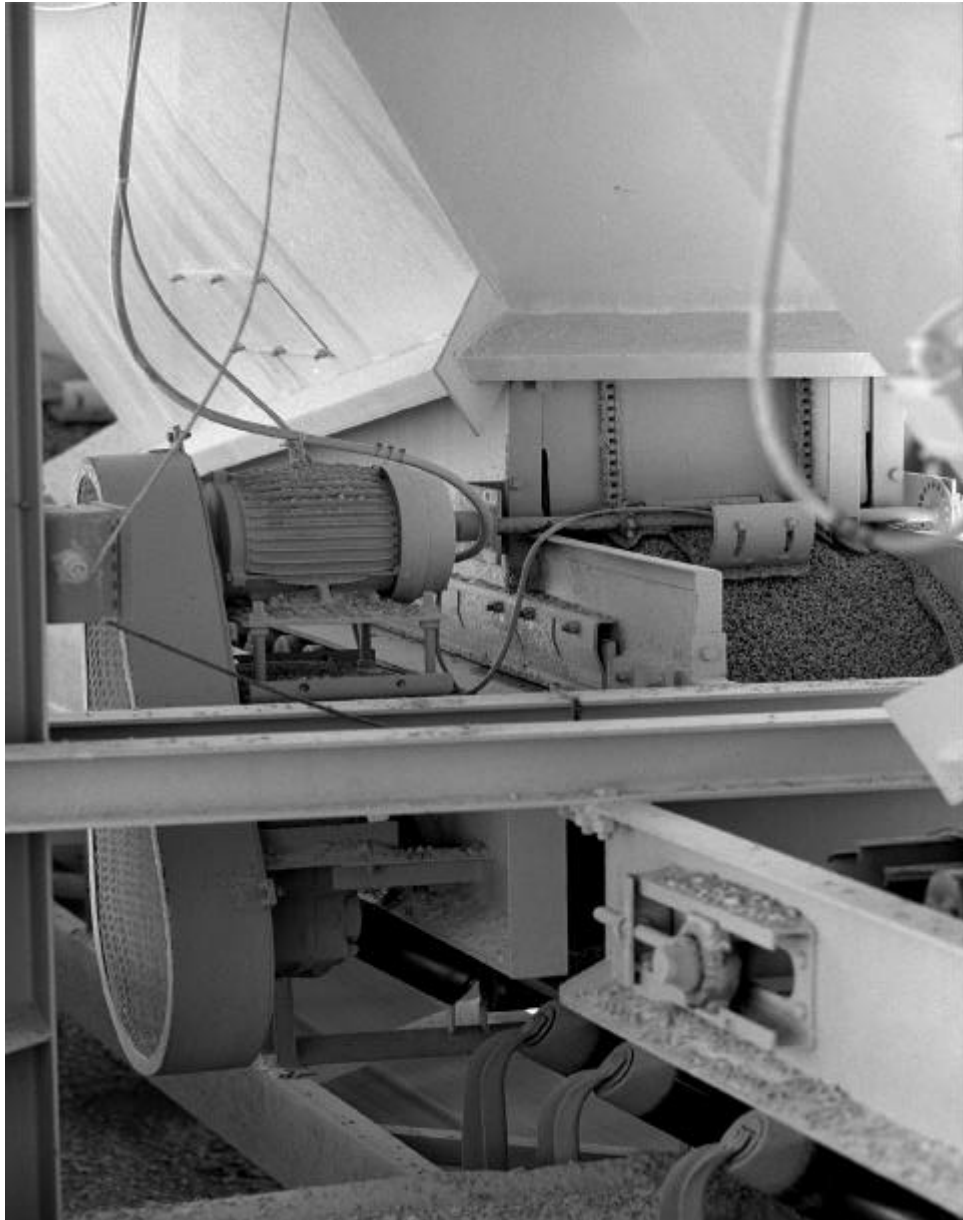

Figure 3.28 Feeder with AC motor and constant speed gearbox.

- AC motor with variable-speed clutch device fitted to a constant-speed gearbox as shown in figure 3.29.



Figure 3.29 Feeder with TASC drive fitted to constant speed gearbox.

- Conventional constant-speed AC motor fitted to a variable-speed gearbox as shown in figure 3.30.

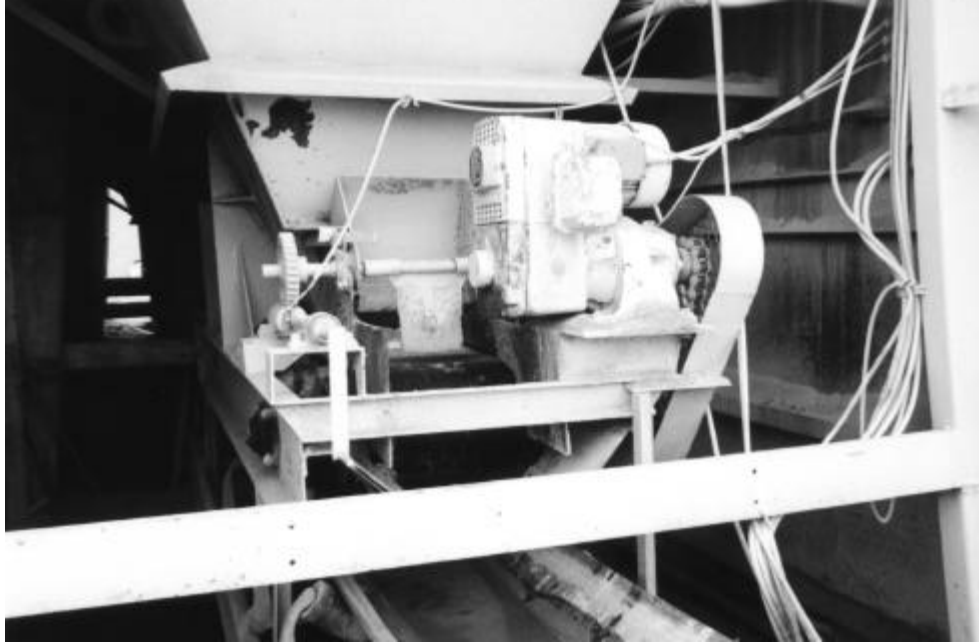

Figure 3.30 Feeder with Reeves variable speed gearbox drive.

There is a considerable amount of debate among manufacturers and field personnel as to which style of drive is best, but each type performs satisfactorily for repeatable and consistent flow control. The different types of drives have really not changed much over the last 15 years. In fact, manufacturers have switched between types and moved from one drive type to another. There is a high probability that on plants equipped with variable-speed belt feeders, one of the above drive types will be found.

In the control room, the panels for each of these drives looks similar. Modern control panels typically have digital speed display meters, and offer total and proportional control dials or thumbwheels. Computers can be programmed to drive the feeders from stored mix formulas recalled by the operator. A computerized system is typically used for a drum-mix plant and can be used for a batch plant.

3.6 FLOW OF MATERIAL FROM THE FEED BIN AND FEED HOPPER

Hopper Design

Regardless of what type of aggregate storage system is used, some type of feeder will be used to convey material to the hot-mix plant and fitted immediately above the feeder will be a feed hopper. For plants with cold-feed bins, the bottom of the bin is also the feed hopper. For plants with bunker-feed systems, a small hopper sits directly above the feeder and is usually fitted below the concrete floor of the bunker.

Experience has shown that trapezoidal openings as shown in figure 3.31, promote better flow of material than rectangular openings. Notice that in figure 3.32 the "live" area of the hopper covers the entire cross-sectional area of the hopper with the trapezoidal design.



Figure 3.31 Feeder belt and hopper showing trapezoidal shape to opening.

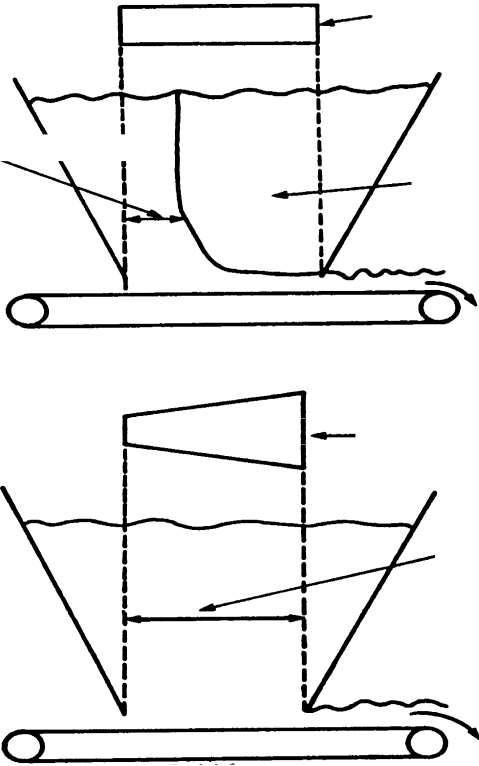

Figure 3.32 Effect of bin opening shape on material flow.

With a rectangular design, the leading edge of the rectangle can act like a material dam, keeping material from flowing from the bin. The trapezoidal opening, therefore, offers not only better flow of material from the feed hopper but also better control of the feed rate from the hopper. Most manufacturers now use trapezoidal hopper designs.

Bridging

Bridging is a term used when the cohesion of the material keeps material from flowing. It is termed "bridging" or "bridging over" because the material forms a natural arch bridge inside the bin or hopper. If one could look up inside the hopper or bin as shown in figure 3.33, it would appear as if the material was hollowed out immediately above the feeder. If the material bridges over in a drum-mix plant and there is no way to detect it, serious consequences can result to mix gradation and mix quality. For this reason, most drum-mix plants are fitted with paddles and limit switches to detect no-flow conditions as shown in figure 3.34.

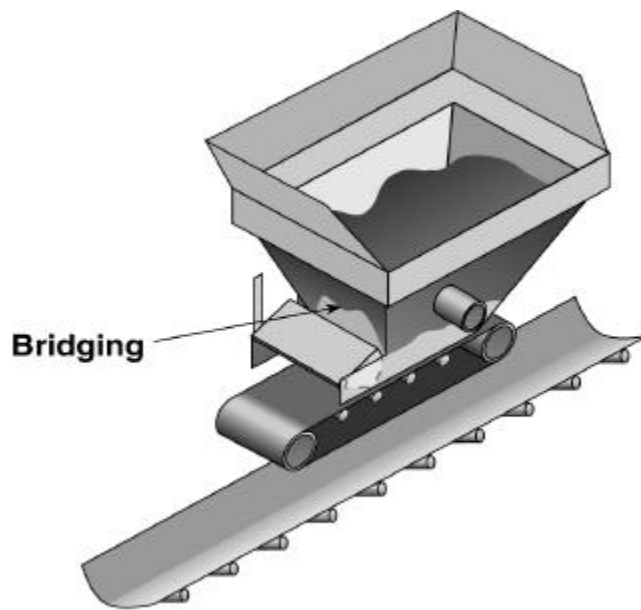

Figure 3.33 How material bridges in a bin.

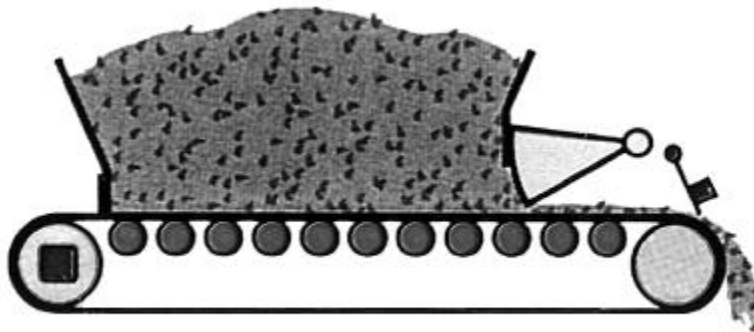

Figure 3.34 Feeder with no-flow switch, tachometer, and manually adjustable clam gate.

No-flow conditions in a batch plant also cause operational difficulties. Although mix quality will not be directly affected at the cold-feed end, the plant will eventually run out of material for a hot bin if a feeder stops flowing. The plant will have to be shut down and the problem corrected in order to continue production. The trapezoidal shape of the hopper discussed above reduces the possibility of bridging, but it won't eliminate it. Vibrators are often installed to shake the hopper or feed bin walls to cause the material to lose its cohesion, or "break the bridge." These can be operated manually or be set to operate automatically.

"Air Cannons" or "Blasters" as shown in figure 3.35 are also used to dislodge packed or bridged materials. These devices have a large reservoir that is filled with compressed air. When activated, the compressed air is released from the reservoir sending a jet of air through a pipe into the feed bin. This device is very effective in dislodging bridged material and is frequently found on RAP bins.



Figure 3.35 Bin wall vibrators and air cannon on cold feed bin.

Ceramic and high molecular weight plastics are also popular preventative methods for bridging. These materials make the bin wall slicker, which keeps the material from adhering to the wall, and helps keep the bin free-flowing.

Partial Flow from Belt Slippage

Feeder speed displays are necessary in order to control gradation at the cold feed. In recent years it has become increasingly popular to drive the feeder speed display from a tachometer mounted on the tail shaft of the feeder belt as shown in figure 3.36 for one reason -- if a feeder belt starts slipping and partial flow develops, the feeder controls can catch it.



Figure 3.36 Tachometer on tail shaft of feeder to detect belt slippage or breakage.

If the feed control system is automated, it will automatically increase feeder speed to obtain the flow needed. If the feeder speed is manual, a tachometer on the tail shaft allows the operator to see the partial flow with a glance over the panel and quickly correct it. Drive belts slipping on the feeder motor or feeder gearbox can have the same effect as the feeder belt slipping on the head pulley. A tachometer fixed to the tail shaft will catch either condition.

Partial Flow from Restrictions

Partial flow can also be caused by foreign material in the cold-feed bins or feed hopper. There is no automated monitoring procedure for this condition, other than the total flow deviation alarm that might be part of the control system of a drum-mix plant. Each plant typically has a groundsperson whose job is to constantly walk around the plant and visually check drive motors, bearings, belts, and fittings to ensure that everything is operating properly. Part of this employee's routine task is to clean the belt transfer points, under the feeders, and check that the flow of material is not hindered in the cold-feed system.

Other ways to prevent partial flow in equipment design are to install scalping screens over the feeder openings, or weigh the material from each feeder with a belt scale. Partial flow can also occur if sticky, wet, or clay-type materials collect on the bin sidewalls in sufficient quantities to choke down the opening to the feeder. Bin vibrators help reduce this possibility. Ultra High Molecular Plastic (UHMW) or ceramic tile liners also help reduce this possibility.

3.7 RAP COLD-FEED BINS

RAP bins require different shapes from conventional cold-feed bins for a variety of reasons. Frequently a large percent of total production is run through a RAP bin. In a drum-mix plant, running 363 tonne/hr (400 tph) of a 50 percent recycle mix, amounts to half the production from one bin:

$$363 \text{ tonne/hr} \times 50\text{percent} = 181 \text{ tonne/hr of RAP required}$$

In a batch plant, while the percent of total production is not substantial (usually no more than 25 percent), the feed rate required from the bin is substantial when you take into consideration the time allowed to meter that amount of material into the plant. For instance, a 4,536 kg batch plant with a 45-second batch cycle, running 25 percent RAP, requires a RAP feed bin to operate as follows:

$$\begin{aligned} 4,536 \text{ kg} \times 25\text{percent} &= 1,134 \text{ kg batch} \\ 1,134 \text{ kg in 15 seconds} &= 4,536 \text{ kg per minute} \\ 4,536 \text{ kg per minute} &= 272 \text{ tonne ton per hour} \end{aligned}$$

Regardless of whether a RAP bin is on a drum-mix plant or a batch plant, a RAP bin must be very large and fitted with more horsepower than virgin aggregate bins on the same size plant. RAP also doesn't flow as well as virgin aggregate. It bridges easier than virgin aggregate due to the moisture, the asphalt binder, and the dense composite gradation of RAP materials. It is not unusual to see a laborer positioned directly above a RAP bin with a long pole to help reduce the bridging and increase the flow of RAP from a bin.

Unlike sand bins, vibrators do not help the flow of RAP from a cold feed bin. In fact, they only seem to increase the likelihood of bridging. This is probably due to the dense composite gradation of RAP from 50 mm down.

RAP material also has a tendency to compact in the bin, especially on hot and humid days. It is theorized that this tendency toward compaction is due to the percentage of AC in the RAP, the dense gradation of the RAP, and the cohesive properties of the asphalt binder. Taking all these things into consideration, RAP bin designs have evolved significantly since the early 1980s to eliminate the feed problems characteristic of RAP. RAP bins have inclined feeders as shown in figure 3.37, and steeper side walls, shallower hoppers, longer gate openings, and more horsepower than aggregate feeder designs. They are frequently fitted with blasters instead of vibrators to break the bridge. Figure 3.38 shows twin RAP bin system with long RAP feeders.

Many RAP bins are also fitted with "lump breakers" at the discharge of the feeder belt as shown in figure 3.39. These breakers resemble small roll crushers. They are used to reduce the particle size as it flows from the bin to the plant. Smaller RAP particles heat quicker and become part of the virgin/RAP recycled mix faster than larger particles. Because both production and quality are protected with smaller RAP particles, this type of equipment is found fitted to many plants.

The unique feed characteristics of the RAP bin, or rather the possibility of reduced flow from the RAP bin due the nature of RAP materials, can cause mix quality problems in the final mix. This has been a problem for plant manufacturers and plant operators alike. It would be of greater concern if plant control equipment was not designed to protect mix quality by measuring the flow of RAP as it leaves the bin and enters the plant.



Figure 3.37 Incline RAP feeder.



Figure 3.38 Twin RAP bin system with long RAP feeders.

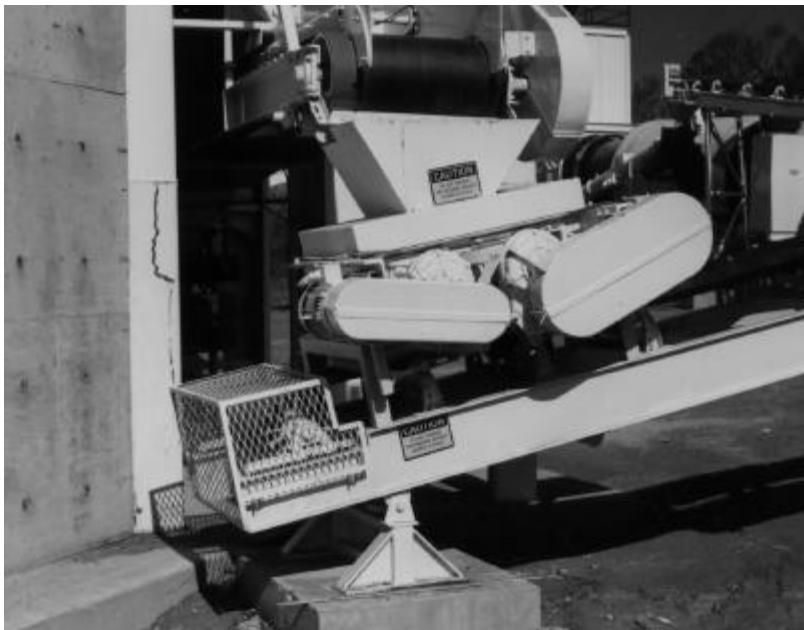

Figure 3.39 RAP bin with lump breaker at discharge.

On drum-mix plants, RAP conveyors have their own belt scales to measure flow. The feed from the bin is tied to the production requirements and measured by the belt scale. If flow decreases, the control system will automatically speed up the belt to compensate. If the flow does not change within a prescribed time frame, an out-of-tolerance alarm will alert the operator to a potential quality control problem. In batch plants, the RAP is also weighed as it enters the plant, either by introducing the RAP directly into the weigh box or by weighing it with a separate weigh hopper or belt scale. Still, every precaution needs to be taken by plant personnel to see that the RAP material feeds evenly and consistently from the bin to the other plant equipment.

Collecting Conveyors

Fitted below each feeder and feed hopper is a collecting conveyor as shown in figure 3.40. The purpose of the collecting conveyor is to "collect" the material from each feeder and transfer it to the conveyor charging the dryer. Collecting conveyors typically end at the feeders, and material is then transferred to another "transfer conveyor." But collecting conveyors can be used to feed up and onto screen decks, or go all the way to the dryer. The conveyor used to feed material into the dryer is typically referred to as the "charging conveyor" or "feed conveyor" on a batch plant as shown in figure 3.41, and the "belt-scale conveyor" on a drum-mixer.

On batch plants this is simply the final conveyor used to feed aggregate to the dryer -- hence the term "charging conveyor" or "feed conveyor." On drum-mix plants this is also the conveyor that is fitted with the belt scale for weighing the aggregate for control purposes -- hence the term "belt-scale conveyor".

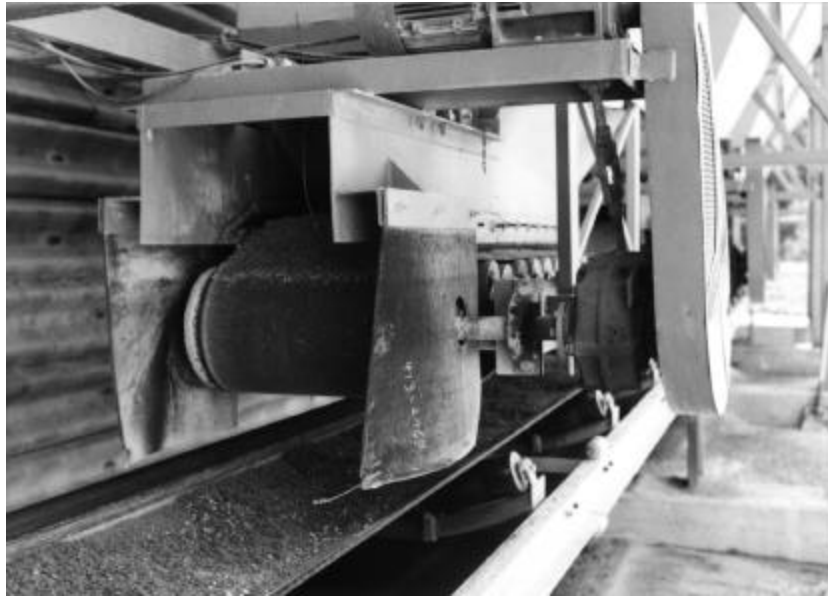

Figure 3.40 Collecting conveyor under cold feed bins.



Figure 3.41 Dryer feed conveyor on batch plant.

Belt-scale conveyors typically have a gravity take-up mechanism installed that keeps the belt taut and the belt-scale reading accurate. It also frequently has wind guards around the scale so that the wind

cannot influence the load cell reading. Belt-scale conveyors need to be checked periodically for accuracy, and recalibrated when necessary.

Scalping Screens

On a drum-mix plant, a scalping screen is typically located at the transfer point between the collecting conveyor and the belt scale conveyor. The purpose of the scalping screen is to ensure the quality of the mix by removing any oversize materials that may have contaminated the aggregate mixture between the quarry and the hot-mix plant.

In a drum-mix plant, this is typically the only point where screening is being done, although technically, screening is not the proper term. The scalping screen is not used to size aggregates; it is only being used to catch oversize materials. Scalping screens are typically sized slightly larger than the top size of the material being used in the mix. For instance, a 16 mm screen cloth might be used for a 12.5 mm top-sized mix formula, while a 44 mm screen cloth might be used for a 37.5 mm top-sized mix formula.

In determining dimensions and horsepower of scalping screens against production rates of the plant, it is best to consult a plant manufacturer. Scalping screens are selected differently than material sizing screens used in rock production at quarries, and a certain amount of "art" is involved, based on characteristics in local aggregates. Figure 3.42 shows single deck scalping screen on drum-mix plant.

Many metropolitan drum-mixers are fitted with double-deck scalping screen as shown in figure 3.43 so that oversize materials can be scalped from both large-stone mixtures and small-stone mixtures without shutting down production to change screen cloth. This is done with remotely controlled, air-operated deck selector.



Figure 3.42 Single deck scalping screen on drum-mix plant.



Figure 3.43 Double deck scalping screen on drum-mixer with air operated deck selector.

An alternative approach to scalping screens for a drum-mixer is to install individual screens below each material feeder as shown in figure 3.44. This eliminates the need for a multiple-deck scalping screen because each material is "scalped" individually.

3.8 FINE, BULK MATERIAL AGGREGATES INTRODUCED AT COLD FEED

Sometimes it is necessary to introduce fine mineral aggregates at the cold-feed end of the plant as displayed in figure 3.45. Two popular examples are stone screenings for gradation correction and lime for anti-strip control.

Stone Screenings

Stone screenings typically have their own cold-feed bin. This bin is usually smaller than other cold-feed bins and sometimes is enclosed if the moisture content of the dust is low. These bins function essentially the same as other cold-feed bins and usually have a smaller belt feeder with a variable speed drive attached. Variable speed screw conveyors can also be used.



Figure 3.44 Cold feed system with scalping screens installed on each feed conveyor.



Figure 3.45 Dust bin at the end of a cold feed system.

Bulk Lime (Lime Silos)

Bulk lime is sometimes used as a way of treating aggregate prior to the drying process to reduce the stripping effect of liquid asphalt on some aggregates. When bulk lime is added to the aggregates, it is usually metered from a silo directly onto the aggregate as it flows down a conveyor enrobe to the drum. Lime silos can also sit adjacent to the belt conveyor as shown in figure 3.46 with a screw conveyor feeding the lime onto the aggregate. Lime can be added volumetrically or by weight. Adding bulk lime to the aggregate is essentially the same as adding baghouse fines back into the production process of a drum-mix plant after the fines have been stored in a silo. Some states require that the lime be thoroughly mixed with the wet aggregates prior to drying. A popular approach to meet this requirement is a continuous pugmill.



Figure 3.46 Lime silo sitting over a belt conveyor.

A continuous pugmill for lime looks very similar to one used to make hot-mix. Typically they are not as long and have less horsepower. There is no need to heat them or to equip them with sophisticated wear liners. These pugmills are typically located at a transfer point between belt conveyors leading to the dryer or drum-mixer as shown in figure 3.47. They are usually installed with a divert chute so that material does not always need to flow through them and they can be put into operation only when required.

3.9 LIQUID ADDITIVES INTRODUCED AT COLD FEED

Lime slurry can also be added to aggregates for anti-strip control at the cold feed prior to the dryer. Currently this is the only type of liquid additive used for treating aggregate, but the procedure employed would be typical of most other types of chemical additives that would be required for treating aggregate instead of asphalt.

With lime slurries, a typical blend of 25 percent lime and 75 percent water is mixed and stored in a bulk tank. The slurry is then metered and sprayed on the aggregate, based on a proportion of the total virgin aggregate flow. Slurry can either be measured volumetrically or metered onto the aggregate. Volumetric control consists of calibrating a pump and flow control valve, much as one would calibrate a feeder. Systems can be sophisticated or relatively simple. Simple systems involve a manual control for the operator with a digital position meter; the flow is controlled manually like that of a cold-feed bin. Sophisticated systems use a feedback signal to a control system, with the slurry being part of the mix formula and/or tied to a belt-scale signal.



Figure 3.47 Continuous pugmill for mixing lime with aggregate prior to entry to dryer or drum-mixer.

Metered control consists of a flow meter installed in the slurry line and use of the metered signal to establish slurry flow. Again, systems can be simple or sophisticated. Simple systems involve manual control for the operator, but the output from an actual flow meter is useful to regulate flow rate.

Sophisticated systems are the same as described above, but use the signal from the meter as a feedback signal to a control system.

Aggregate does not necessarily have to be treated as it is fed to the dryer. Some states allow, and/or special projects require, aggregate to be treated in bulk prior to being fed with a loader into the plant. In this situation, aggregates are charged into the bin of a CTB (cement-treated base) type plant fitted with a continuous pugmill mixer as shown in figure 3.48, and the lime slurry is added to the aggregates in the mixer. The aggregates are then re-stockpiled on the ground and fed into the plant at a later time. The same type of slurry pumping and measuring equipment is used with this approach as is used when treating aggregates as they enter the dryer.

If plants are not fitted for regular slurry processing, or a special project requires use of a slurry, then this preprocessing of aggregates is often used. Other types of liquid chemicals used to treat aggregates could be applied as well with the approaches discussed above.

3.10 AGGREGATE SAMPLING AND TESTING

Aggregates are typically about 95 percent of the HMA mixture. Therefore, it is important that the gradation and quality of the aggregate be known to assure that a quality mix is produced. There are a number of tests performed on aggregate to determine their quality or acceptability. These tests may include the following: gradation, moisture content, flat-and-elongated particles, Fine Aggregate Angularity,

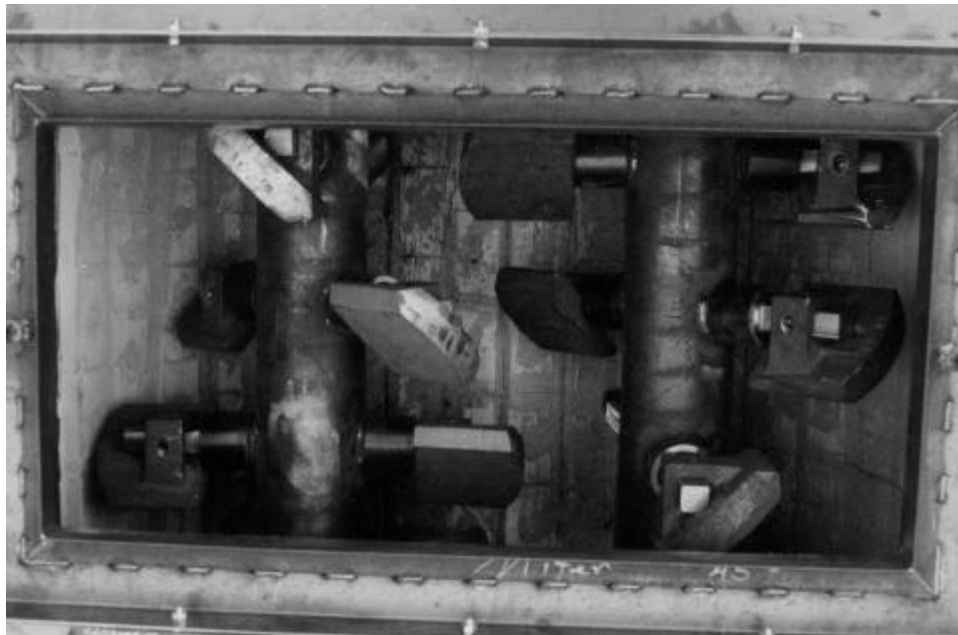

Figure 3.48 Close-up of pugmill used to mix lime with aggregate.

LA abrasion, crushed particles, and sodium sulfate soundness, to name a few. For the test to be meaningful, the sample must be representative, and the test must be performed in accordance with established procedures. The sampler must use every precaution to obtain samples that will show the nature and condition of the materials they represent.

There are three principals to obtaining a representative sample:

1. Select sample units using random sampling procedures.
2. Use proper sampling procedures.
3. Obtain sufficient material based on the type and number of tests to be performed.

Sampling Procedures

Random sampling is only one portion of the sampling plan; the next step is to use proper sampling procedures. AASHTO T2 and ASTM D75 cover sampling of coarse and fine aggregates for the following purpose:

1. Preliminary investigation of the potential source of supply
2. Control of the product at the source of supply
3. Control of the operations at the site of use
4. Acceptance or rejection of the materials

The coarse and fine aggregate delivered to the manufacturing facility must contain the proper proportion of all the sizes specified in the job-mix formula. The facility cannot make sizes; it can only reject sizes larger than specified and adjust blend proportions. Therefore, it is best to sample the stockpile as it is being built rather than after the fact.

Sample Size: A key item to remember is to always obtain more material than is necessary to perform the test or tests that will be required. The sample quantity obtained should be at least four or five times more than the weight required for the particular test. If more than one test is going to be conducted, then the sample quantity should be further increased by the number of tests to be conducted from the single sample. This is true no matter where or how you are sampling.

Sampling Stockpiles As They Are Being Built: This is the best method according to technical representatives. Two procedures can be used to sample stockpiles as they are being built. The most common method is to sample from a flowing aggregate stream since production does not have to stop. The entire cross section of the material is sampled as it is being discharged. Typically, a special device is constructed for this purpose at each particular plant. At least three approximately equal increments should be obtained and combined to form a field sample with enough mass to perform the required tests.

The other procedure for sampling during production is to sample from the belt. This requires stopping production during sampling. Obtain three approximately equal increments, selected at random, and combine to form a field sample with enough mass to perform the required tests. The conveyor belt is stopped (using proper lock out/tag out safety procedures) while the sample increments are being obtained. Insert two templates, the shape of which conforms to the shape of the conveyor belt in the aggregate stream on the belt, and space them in such away that the material contained between them will yield an increment of the required weight (approximately 0.6 m.) Carefully scoop all material between the templates into a suitable container and collect the fines on the belt with a brush and dust pan and add to the container. Be careful not to remove fines that would normally adhere to the belt.

Sampling Existing Stockpiles: It is difficult to obtain a reliable sample from a coned stockpile of coarse aggregate, and test results made on samples from such a pile may be very misleading. The tests may indicate that certain particle sizes are present, but the percentages indicated can be widely different from the true average percentage in the entire stockpile. If absolutely necessary to obtain a sample, the best

way is to knock off the top of the coned pile with a front-end loader. A composite sample can then be obtained by combining small portions taken at random locations from the flat surface.

For large stockpiles it may not be possible to knock off the top of the pile. For such piles every effort should be made to enlist the services of power equipment to develop a separate, small sampling pile composed of materials drawn from various levels and locations in the main pile, after which several increments may be combined to compose the field sample. If necessary to indicate the degree of variability existing within the main pile, separate samples should be drawn from separate areas of the pile.

When power equipment is not available, field samples should be made up by sampling at least three increments taken from the top, middle, and bottom third of the volume of the stockpile. Remember, in cone-shaped stockpiles most of the volume of the stockpile is near the bottom. The graph in Figure 4.50 shows the relationship between a given height in a stockpile and the percent of the total volume of the stockpile. As you can see in this graph, over 50 percent of a cone-shaped stockpile's volume is contained in the bottom quarter of the stockpile. Therefore, the three incremental samples should be taken between 0 - 12, 12 - 32, and 32 - 100 percent of the stockpile height. With coarse aggregate stockpiles a board should be pushed into the stockpile just above the area to be sampled to avoid obtaining segregated material that often rolls to the outside of stockpiles.

Sampling from Railroad Cars or Trucks: Coarse aggregates received in railroad cars are best sampled from a belt or truck during unloading. If sampling is necessary before unloading, three or more trenches at least 0.3 m deep should be dug across the car and portions for a composite sample taken from the bottom of the trench.

Fine aggregate in a stockpile, or in barges or railroad cars, can be sampled with a thief sampler. This is a piece of 25 mm pipe, about 1.5m in length equipped with a "t" handle and slotted along one side. The pipe is forced into the mass of aggregate as far as possible, given a turn, and pulled out. The samples can be removed by pushing out small portions with an object, such as a large nail inserted in the slot.

Sampling from Cold-Feed Bins: Samples of individual aggregate may also be obtained from the openings of the cold-feed bins when the facility is not producing mixture. Remember to use proper lock out/tag out safety procedures when sampling from cold-feed bins.

Sampling Blended Aggregate from Feed Belts: The best way to get a sample of blended aggregate is from the conveyor belt. If available, a sampling device that allows sampling from a moving belt should be used. If a continuous sampling device is not available, stop the belt (using proper lock out/tag out safety procedures) and place three short sections (approximately 0.6 m) of the aggregate from three separate locations into a container. Care must be taken not to remove the material that normally sticks to the bottom of the belt.

Reducing Field Samples for Testing: ASTM C702 (AASHTO T248), Reducing Field Samples of Aggregate to Testing Size, presents methods for reducing field samples to test sample sizes. The coarse aggregates should be split or quartered to the proper testing sample size. Fine aggregates may be split or quartered to test portion size, but this must be done while the sample is still moist to prevent loss of fines. Care must be used to ensure a representative belt sample is obtained. Natural and manufactured sands may not be evenly distributed over a 0.6 m length of belt. As a result, multiple samples are necessary.

Each test procedure provides minimum test portions that are typically based on the maximum size of the aggregate being tested. The larger the aggregate size, the larger the test portion and therefore the larger the size of sample required. In general, the larger the mass of the test portion, the greater the

accuracy. A single sample, composite or otherwise, does not provide much information. The results of tests on five or more samples should be averaged to obtain a reliable estimate of the true gradation.

The following table extracted from ASTM D-75 provides minimum recommended sample sizes based on maximum nominal aggregate size.

Table 1: Recommended sample sizes based on maximum nominal aggregate size (ASTM D-75)

Maximum Nominal Size of Aggregate	Approximate Minimum Mass of Field Samples, lb. (kg)
Fine Aggregate	
No. 8 (2.36 mm)	25 (10)
No. 4 (4.75 mm)	25 (10)
Coarse Aggregate	
3/8 in. (9.5 mm)	25 (10)
1/2 in. (12.5 mm)	35 (10)
3/4 in. (19.0 mm)	55 (25)
1 in. (25 mm)	110 (75)
1-1/2 in. (37.5 mm)	165 (75)
2 in. (50 mm)	220 (100)

These sample sizes are tentative. The actual sample size must be determined based on the type and number of tests to be performed. The sample size should be four to five times the mass of material required for each individual test.

Assume that a sample will be taken from a 19.0 mm aggregate stockpile for gradation only. ASTM C136 specifies a minimum test sample size of 5 kg. Therefore, the field sample size should be at least 20 kg. For more tests, a larger field sample may be required. The quantities listed in table 1 are adequate for routine gradation and quality analysis.

Routine Aggregate Tests for Facility

The whole purpose of using random sampling and proper sampling procedures is to obtain representative material for laboratory testing. The next step is to test the material in accordance with established test procedures. Using shortcuts or varying from established test procedures should not be allowed. These variations will usually result in errors that invalidate the test results.

Field laboratories should be equipped to perform those tests that are performed daily and weekly, or those tests whose answers are required almost immediately in the quality control process. The scope, summary, and potential testing problems for each test method are discussed below. The tests and equipment generally included in this category are as follows:

Total Moisture Content of Aggregate by Drying (AASHTO T255, ASTM C566): covers the determination of the percentage of moisture that can be evaporated from a sample of aggregate by drying. The test method is sufficiently accurate for usual purposes, such as adjusting batch weights of aggregates. In cases where aggregate itself is altered by heat, or where more refined measurement is required, the test should be conducted using a ventilated, controlled-temperature oven.

Sieve Analysis of Fine and Coarse Aggregate (AASHTO T27, ASTM C136): covers the determination of the particle size distribution of fine and coarse aggregates by sieving. The results are used to determine compliance of the particle size distribution with applicable specification requirements and to provide necessary data for control of the production of various aggregate products and mixtures containing aggregates. For HMA operations, a washed sieve analysis (T11, C117) should be conducted on all samples. Care should be taken to obtain the proper sample size for each material and not to overload any of the sieves in the shaking process.

Materials Finer Than 0.075 mm (No. 200) Sieve in Mineral Aggregates by Washing (AASHTO T11, ASTM C117): (also called a washed sieve analysis) covers determination of the amount of material finer than a 0.075 mm (No. 200) sieve in aggregate by washing. Clay and other aggregate particles as well as water-soluble material are dispersed by the wash water and are removed from the aggregate during the test. Material finer than the 0.075 mm (No. 200) sieve can be separated from larger particles much more efficiently and completely by wet sieving than through the use of dry sieving. Therefore, this test method should be used on the sample prior to dry sieving. The results of this test method are included in the calculation in Method T27 or C136. The total amount of material finer than 0.075 mm by washing, plus that obtained by dry sieving the same sample, is reported with the results of Method T27 or C136. Usually, the additional amount of material finer than 0.075 mm obtained in the dry sieving process is small. If it is large, the efficiency of the washing operation should be checked. A large amount of material finer than 0.075 mm could also be an indication of degradation of the aggregate.

Specific Gravity and Absorption of Coarse Aggregate (AASHTO T85, ASTM C127): covers the determination of specific gravity and absorption of coarse aggregate. The specific gravity of an aggregate may be expressed as bulk specific gravity, bulk specific gravity (SSD) (saturated-surface-dry), or apparent specific gravity. The bulk gravity (SSD) and absorption are based on aggregate after 15 to 24 hours soaking in water, depending on whether the AASHTO or ASTM method is used. Neither test method is intended to be used with lightweight aggregates.

The definition of the SSD for the aggregate during the test has a large effect on the test results. To establish this condition, the aggregate should be surface dried with a damp towel and weighed immediately after that condition is reached. Bulk specific gravity of aggregate is the characteristic generally used for calculation of the volume occupied by the aggregate (VMA) in HMA mixtures. Test results should be reported to three decimal places.

Specific Gravity and Absorption of Fine Aggregate (AASHTO T84, ASTM C128): covers the determination of bulk and apparent specific gravity and absorption of fine aggregate. Bulk specific gravity of aggregate is the characteristic generally used for calculation of the volume occupied by the aggregate (VMA) in HMA mixtures. The definition of the SSD for the aggregate during this test has a large effect on the test results. The percentage of material passing the 0.075 mm (No. 200) sieve may distort the ability to identify the SSD point. Some agencies wash all their fine aggregate samples prior to running the specific gravity test. Highly crushed fine aggregates seem to trick the cone test into identifying the aggregate as SSD when it is not. It is a good practice to conduct the air drying of the aggregate in a aluminum baking pan with a scratched, worn bottom. In this type of pan the aggregate will leave a damp spot while it still contains surface water. The bottom of the pan will be dry when the aggregate is SSD. Some technicians use a vacuum to remove the trapped air from the sample prior to determining the final weight of the flask filled with aggregate and water. This technique should not be used because it increases the amount of absorbed water in the sample from the amount determined in the prior SSD weighing. Using a vacuum will result in an error in the specific gravity determination. Test results should be reported to three decimal places.

3.11 REFERENCES

1. 1.FAA Circular AC 150/5370-14, *The Hot Mix Asphalt Paving Handbook*, pp.10-23.
2. IS-123, *Recycling Hot Mix Asphalt Pavements*, National Asphalt Pavement Association, Lanham, MD.
3. MS-2, "Mix Design Methods for Asphalt Concrete and Other Hot-Mix Types," Asphalt Institute, Lexington, KY.
4. *Pavement Recycling Executive Summary and Report*, Federal Highway Administration publication No. FHWA-SA-95-060.

QUALITY AND EFFICIENCY TIP (s)

Feeding RAP Bins

Because of the natural feed difficulties of RAP in hot-mix production, most loader operators have learned to use the following procedures for RAP feed bins:

“Trickle-feed” the bin. Trickle the RAP from the loader bucket into the RAP old-feed bin. Do not charge the bin with a full bucket quickly. The RAP has a tendency to compact upon the force in the bin and bridge over.

Do not heap the RAP bin to capacity. Better to feed the RAP frequently, and keep the bin only half full than to spend the down-time digging out a bin that compacts and bridges over.

Do not let the RAP sit in the bin for long periods of time during shutdown, especially on warm, humid days. Better to empty the bin and re-charge than spend the downtime and undergo the aggravation of digging out. No more than two hours in the bin is a good rule of thumb.