

TECHNICAL PROPOSAL

IS-695 from IS-70 to MD 43 Transportation Systems
Management and Operations
Design-Build

Baltimore County

Contract No. BA0065172 | F.A.P. No. AC-NHPP-695-6(385)N





TABLE OF CONTENTS

2.09.01 COVER LETTER	
2.09.02 PART-TIME SHOULDER USE	1
2.09.03 MOBILITY	21
2.09.04 SAFETY	41
2.09.05 OPERABILITY/MAINTAINABILITY/ADAPTABILITY	61
2.09.06 APPENDIX	
– ELECTRONIC COPY OF THE VISSIM TRAFFIC MODELS FOR 2018 AND 2040 DESIGN YEARS AND CONCEPT EVALUATION TEMPLATES	
– NOTICE TO PROPOSERS	A-1A
– ADDENDUMS 1-3	A-1
– REQUEST FOR PROPOSALS QUESTIONS & RESPONSES	A-17
– INCORPORATED PTCs ATCs	A-91

2.09.02 | Part-Time Shoulder Use



MARYLAND DEPARTMENT
OF TRANSPORTATION™

STATE HIGHWAY
ADMINISTRATION



2.09.02 PART-TIME SHOULDER USE

i. Discuss the locations, including limits and typical section(s) that Corman Kokosing will provide static-dynamic median part-time shoulder use on the outer-loop and inner-loop of IS-695 from IS-70 to MD 43. Discuss how we chose those locations and any features that do not meet or exceed the roadway design and safety guidelines referenced in TC 3.08.

Motorists face significant challenges along the IS-695 corridor regarding vehicle congestion and related incidents that directly affect vehicle delay and travel time. The Corman Kokosing | WSP | MC Dean Design-Build Team's (Corman Kokosing Team) proposed best-value solution will provide the Maryland Dept. of Transportation State Highway Administration (MDOT SHA) with substantial corridor-wide traffic operational benefits while achieving increased vehicle throughput, reduced vehicle travel time, and decreased vehicle incidents. Our best-value solution achieves these objectives through:

Corman Kokosing Team's Improvements will:

- ✓ Add **30 total miles** of new PTS Use Lane (80.5% of the project limits)
- ✓ Reduce travel times up to 55%
- ✓ Increase throughput up to 42%
- ✓ Reduce density up to 38%

- ✓ Maximizing the total length of static-dynamic median Part-Time Shoulder (PTS) Use Lanes within the project limits
- ✓ Incorporating speed harmonization using Variable Advisory Speed Signs (VASS) at key locations where congestion is expected
- ✓ Extending the acceleration lane onto the Inner Loop at the Harford Road Interchange
- ✓ Eliminating and/or mitigating deficient Horizontal Stopping Sight Distance (HSSD) at all locations within the PTS Use Lane
- ✓ Improving monitoring conditions impacting throughput and travel times by providing full-time (24/7) monitoring of throughput, speed, density, and other traffic characteristics in the general-purpose lanes
- ✓ Enhancing Closed Circuit Television (CCTV) coverage for surveillance of roadway operation, over and above what is required per the RFP
- ✓ Enhancing Dynamic Message Sign (DMS) utilization for the speed harmonization system.

Limits of PTS Use Lanes: In this sub-section, we will review the limits of the proposed static-dynamic median PTS Use Lane on the Outer Loop and Inner Loop of IS-695, the process the Corman Kokosing Team followed to select those limits, and the benefits that will be realized by MDOT SHA and motorists. The PTS Use Lane typical section and deficient features are reviewed in later sub-sections.

The Limits: The Corman Kokosing Team proposes to implement **30 miles** of static-dynamic PTS Use Lanes for the stipulated fixed price allocated for this project, in addition to other valuable improvements. Limits of the PTS Use Lanes are defined below and illustrated in **Figure 2-1**.

- ✓ Inner Loop: From IS-70 to Cromwell Bridge Road (15 miles)
- ✓ Outer Loop: From Cromwell Bridge Road to IS-70 (15 miles)

Out of a total project length of **37.28** miles (Inner and Outer loop), our proposed PTS Use Lanes total **30 miles**, or approximately **80.5%** of the total available project limits.

The approach to the PTS Use Lane will be striped with a 500-ft. Type IV *Wide Lane Extension*, 10-in. wide dotted white line (3-ft. line, 3-ft. skip) entrance before starting the actual full width PTS Use Lane with a solid 10-in. wide lane line. The yellow PTS edge-line adjacent to the barrier will also begin with the dotted entrance. This allows motorists to safely identify the start of the PTS Use Lane, and via the Lane Use Control Signs (LUCS), whether it is open or closed and safely enter.

The PTS Use Lane striping will end with a 1,000-ft. stretch of the 10-in. Type IV *Wide Lane Extension*, lane reduction transition arrow markings appropriately spaced, and a 300-ft. taper to end the PTS Use Lane. This will notify motorists of the ending PTS allowing them to safely merge back into the general-purpose lanes.

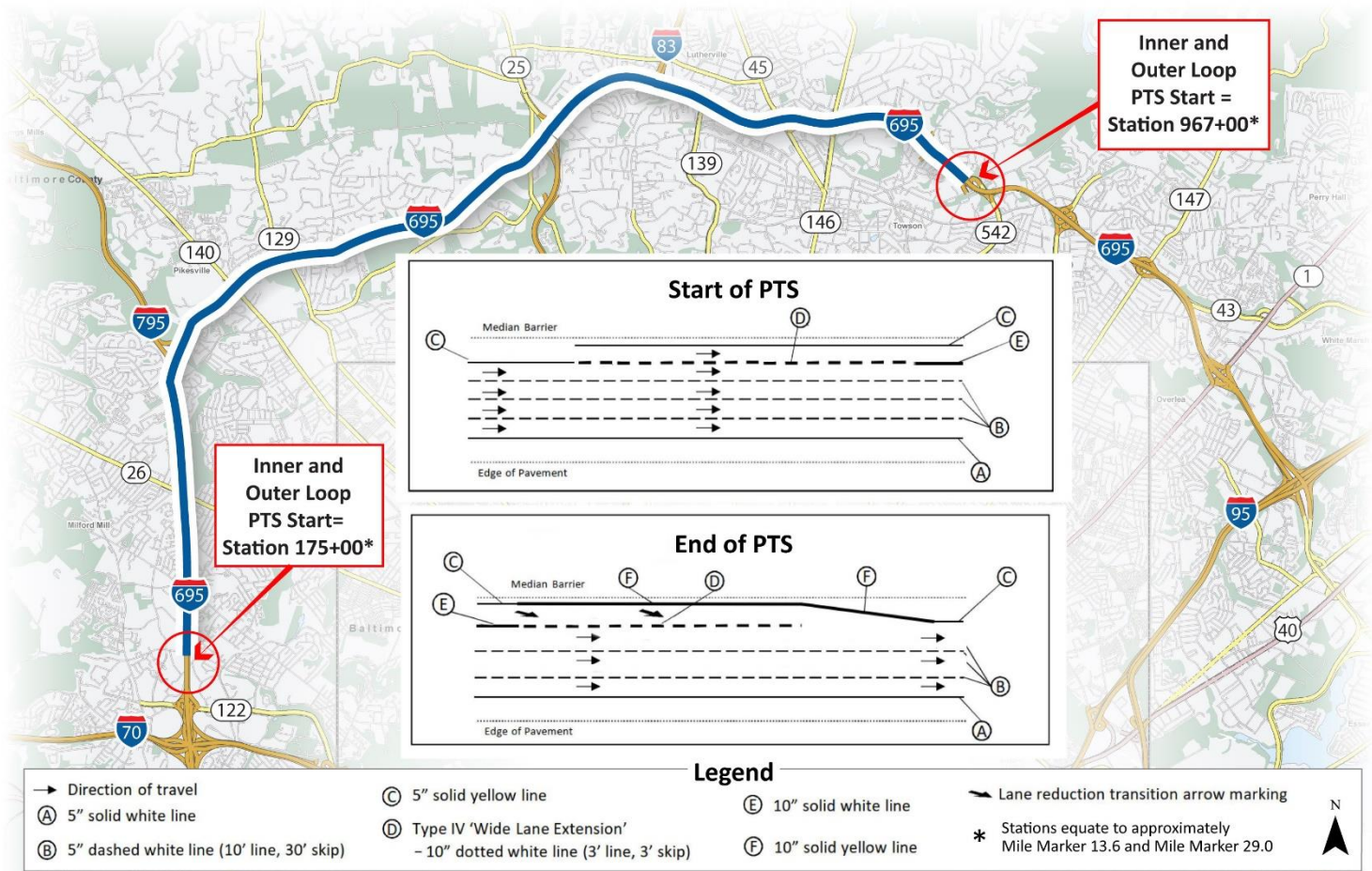

Figure 2-1: Our Limits of PTS Use Lanes and the Typical Striping Geometry to Start and End the PTS

Process for Selecting Limits of PTS Use Lanes: To initiate the process of selecting the proposed limits of the PTS Use Lanes, the Corman Kokosing Team conducted a detailed/iterative traffic analysis using the VISSIM model provided by MDOT SHA. The model was converted to a static model and updated with the correct coding to evaluate the PTS Use Lane for limits of the options evaluated. The model was converted to a static model and updated with the correct coding to evaluate the PTS Use Lane for limits of the options evaluated. Our objective was to determine the mobility benefit (i.e., increased vehicle throughput, decreased travel times, decreased density, etc.) for all potential PTS Limit combinations. We then evaluated each alternative's limits to determine the best value to MDOT SHA and motorists, based on the following primary evaluation criteria:

- ✓ PTS Use Lane Length (linear feet)
- ✓ Travel Time (minutes) Reduction
- ✓ Throughput (vehicles/hour) Increase
- ✓ Traffic Density (vehicles/mile) Reduction
- ✓ Improved Safety (estimated crash rate reduction, reduction in crash severity, resolution of crash hot-spots, etc.)
- ✓ Construction Cost Rating (estimated \$\$/mile)
- ✓ Extent of Geometric (AASHTO/RFP requirements) and Physical (bridges, retaining walls, pinch points, noise walls, SWM facilities, etc.) constraints

These primary criteria were assigned a weighted score; then secondary criteria were incorporated, such as:

- ✓ Constructability (easy-to-difficult)
- ✓ Environmental Impacts (i.e., wetlands/Waters of the US (WUS), air/noise, historic properties, tree impacts and permitting requirements, including erosion & sediment control/stormwater management (ES&C/SWM) (minimal/minor/major)
- ✓ Expected MDOT SHA and Stakeholder Acceptability (yes/no)
- ✓ Additional Right-of-Way Required (yes/no)

Rating/Evaluation: Once the PTS Use Lane limit options were scored based on this criteria, other improvements in addition to the PTS Use Lane were considered to further enhance safety, reduce recurring congestion, and enhance incident management response. These enhancements were factored into the overall calculation of a benefit vs. cost analysis of the total project, to ensure we proposed the optimal combination of improvements.

As depicted in **Table 2-1 (See page 4)**, options for the Inner Loop and Outer Loop were evaluated separately to determine the best overall value to MDOT SHA and motorists. Determination of the PTS Use Lane limits presented in **Table 2-1** also considered the level of construction needed (construction cost and constructability) to meet AASHTO requirements.

For example, HSSD requirements for the PTS Use Lane are not achieved on several curves when the proposed PTS Use Lane is immediately adjacent to the existing median barrier, as the barrier interferes with the required sight distance. Increasing the offset from the median barrier to achieve the required HSSD would increase the cost per mile (due to shifting lanes to the outside and improving the shoulder pavement). This approach is further proven when one considers the reverse curves through the Cromwell Bridge Road/Loch Raven Boulevard Interchange. Given the horizontal geometry of these curves, the expense of widening existing bridge structures, realigning on-off ramps, construction of retaining walls, noise barrier impacts, and other features to mitigate for the reduced HSSD, it was determined not to be a cost-effective solution to mitigate HSSD issues at these two curves considering the limited improvement to mobility. Thus, these curves were considered to have a higher Construction Cost Rating and options, including these curves, were scored accordingly.

Results: The Corman Kokosing Team also concluded from the VISSIM model analyses that it is not effective to implement short gaps in the PTS Use Lane, as friction from merging the PTS Use Lane back into the general-purpose lanes offsets the benefits of the upstream PTS Use Lane. Therefore, implementing options with gaps in the PTS Use Lane limits that would require multiple merge points due to the lane ending, were not considered.

Outcome: The outcome of this preliminary analysis resulted in the PTS Use Lane implementation limits presented in **Figure 2-1 (See page 2)**. Generally, the selected options reflect a greater length of PTS Use Lane associated with a significant improvement in the Travel Time at a cost that aligns with the project stipulated price. Our original option for the Inner Loop turned out to match our final proposal. On the Outer Loop, we originally selected Option D but during further budget refinement we were able to extend it to Cromwell Bridge Rd in our final proposal.

To explain further, the Inner Loop was terminated immediately west of the first curve at Cromwell Bridge Road due to the increase in the Construction Cost Rating if one were to extend further east. The Outer Loop limit was determined because the benefit decreased in relation to the cost to implement the additional length if the limits also extended further east of Cromwell Bridge Road.

The southern (or western) limits of the Inner and Outer Loops indicated a reasonable benefit when considering the primary criteria (especially the total PTS Use Lane length); however, the driving force behind the selection was pushing the limits towards IS-70. This option had a very favorable Construction Cost Rating due to the limited need for large infrastructure improvements when compared to other segments. Security Boulevard serves as the termination point on the southern (or western) limits as this location provided a convenient tie-in point when considering the future IS-70/IS-695 interchange reconstruction project, and precluded an additional friction point to that already being experienced associated with merging and diverging ramp traffic from the Security Boulevard and IS-70 ramps.

Inner Loop			Measures of Effectiveness (MOE)						Benefits					
Total Possible PTS length (Miles from Centerline of IS-70 to MD 43) = 18.65			Length of PTS (miles)	PTS % of Total Possible	Total reduction in TT (min)	% reduction in TT (from No-Build)	Increase in Vehicle Throughput (Veh/hr)	% Increase in Vehicle Throughput	Safety Improvement Rating	Construction Cost	Constructability	Environmental Impacts	MDOT and Stakeholder Acceptability	ROW Impacts
No-Build					207.8		11205							
Base Option	I-70	Cromwell Br Rd	15	80%	86.8	42%	2353	21.0%	HIGH	MEDIUM	MEDIUM	MODERATE	YES	NO
Option A	I-795	Cromwell Br Rd	11.14	60%	96.7	47%	2497	22.3%	MEDIUM	MEDIUM	MEDIUM	MODERATE	YES	NO
Option B	I-795	Charles St/I-83	8.03	43%	40.1	19%	1734	15.5%	LOW	LOW	MEDIUM	MINIMAL	YES	NO
Option G	I-83 (west)	Charles St/I-83	2.71	15%	19.3	9%	1445	12.9%	LOW	LOW	EASY	MINIMAL	YES	NO
Option F	I-83 (west)	US-1	10.35	55%	133.4	64%	2479	22.1%	MEDIUM	HIGH	DIFFICULT	HIGH	CONCERNS	NO
Option H	I-83 (west)	MD 43	8.75	47%	135.2	65%	3383	30.2%	LOW	HIGH	DIFFICULT	HIGH	YES	NO
Option J	Perring Pkwy	US 1	3.34	18%	-1.1	-1%	959	8.6%	LOW	HIGH	DIFFICULT	MODERATE	CONCERNS	NO

Outer Loop			Measures of Effectiveness (MOE)						Benefits					
Total Possible PTS length (Miles from Centerline of IS-70 to MD 43) = 18.65			Length of PTS (miles)	PTS % of Total Possible	Total reduction in TT (min)	% reduction in TT (from No-Build)	Increase in Vehicle Throughput (Veh/hr)	% Increase in Vehicle Throughput	Safety Improvement Rating	Construction Cost	Constructability	Environmental Impacts	MDOT and Stakeholder Acceptability	ROW Impacts
No-Build					402.2		8667							
Option D	Providence Rd	I-70	14.04	75%	290	72%	4252	49.1%	HIGH	MEDIUM	MEDIUM	MODERATE	YES	NO
Base Option	MD-43	I-795	13.68	73%	181.3	45%	2632	30.4%	HIGH	HIGH	DIFFICULT	HIGH	YES	NO
Option A	MD-43	I-70	18.65	100%	277.4	69%	3760	43.4%	HIGH	HIGH	DIFFICULT	HIGH	YES	NO
Option C	MD 45 (York Rd)	I-70	12.54	67%	290	72%	4250	49.0%	LOW	MEDIUM	EASY	MINIMAL	YES	NO
Option E	MD 43	Greenspring Ave	10.59	57%	163.8	41%	2297	26.5%	LOW	HIGH	DIFFICULT	MODERATE	YES	NO
Option I	I-83 (west)	I-70	9	48%	281.2	70%	3460	39.9%	LOW	LOW	EASY	MINIMAL	YES	NO
Option K	Charles St/I-83	I-70	11.57	62%	291.4	72%	2359	27.2%	MEDIUM	LOW	EASY	MINIMAL	YES	NO

SCORING LEGEND

Low/negative scores/ratings for that criteria
 Moderate scores/ratings for that criteria
 High/positive scores/ratings for that criteria

Table 2-1: Analysis of Options

MOE/Criteria Summary: **Length of PTS:** Miles of PTS Use Lane to include in the option | **Travel Time Reduction:** Reduction in minutes of travel time as related to 2040 No-Build Option | **Increase in Throughput:** As it relates to 2040 No-Build Option | **Safety Improvement:** Qualitative assessment of safety improvement for the option | **Construction Cost:** Qualitative rating of construction costs associated with the option; cheaper options mean more budget to provide additional mobility/safety improvements | **Environmental Impacts:** Qualitative rating of environmental impacts, including wetland/WUS, trees, air/noise, historic/archaeology, etc. | **MDOT/Stakeholder Acceptability:** Our assessment of acceptability of the alt. by MDOT and surrounding communities. The extension past MD 43 may have caused some political push-back | **ROW Impacts:** Pass/Fail, ensuring no ROW would be required | **Proposed Option:** This is what the Corman Kokosing Team is proposing. It was the second longest implementation of PTS (second only to the full limits) and had the second highest time savings on the Outer Loop and third highest for the Inner Loop. Additionally, because of its' location avoiding the reverse curves at Cromwell Bridge Road, it scored well on construction cost, constructability, and environmental impacts.

Intelligent Transportation System (ITS) Implementation – Layout and Limits: The following outlines the planned ITS implementation to operate the PTS Use Lane. This system is implemented throughout the project’s PTS limits and had a large impact on determining the PTS limits. Operating parameters of the equipment, installation cost, and concept of operation plan all feed into the per mile cost of the system, which then controls the locations and length of PTS Use Lane that could be included in our proposal.



Our Approach: Provide an Active Traffic Management (ATM) System that controls PTS Use Lane during predetermined hours of operations, allows MDOT SHA to control PTS Use Lane based on emergency or atypical traffic conditions, with the ability for future transition to a fully automated system. The ATM System will use **superior hardware that exceeds RFP requirements**, produce reliable, real-time data, and rugged Traffic Signal Controllers to operate the LUCS over a secure network.

A general layout of the dynamic components of the PTS Use Lane shown are presented in **Figures 2-2 and 2-3**. It was used as the framework for selecting a general cost per segment or mile of the PTS System, which weighed heavily on the process we took to select the limits of our PTS Use Lanes.

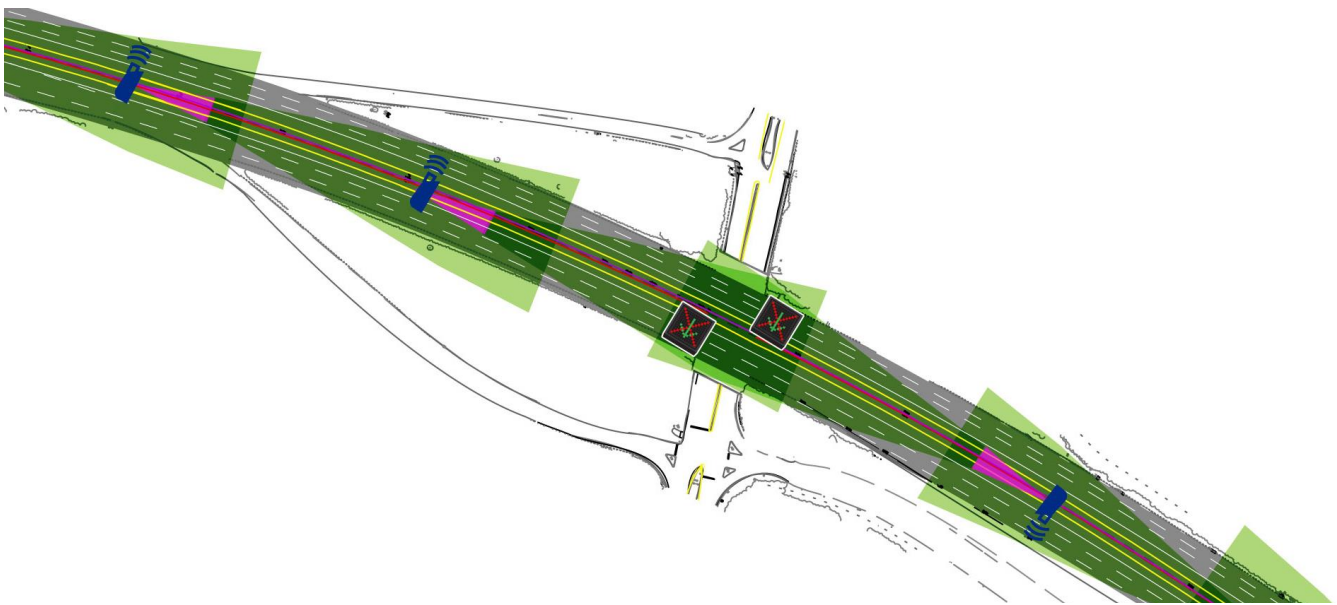
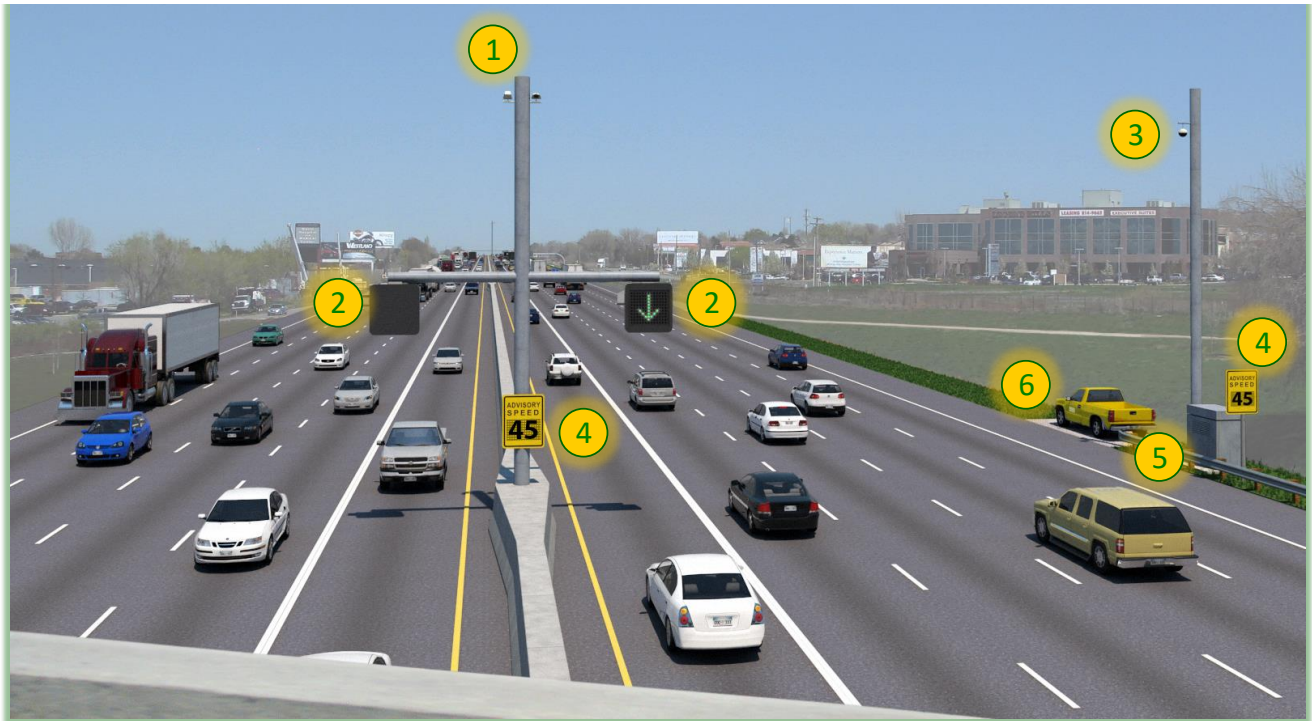

Figure 2-2: Proposed ITS Layout with AID coverage

In **Figure 2-2**, the green areas are the general coverage for each successive AID camera, while the magenta areas show the overlap between two adjacent cameras. You will notice there is 100% coverage of the PTS Use Lanes and approximately 65% to 75% coverage of the general-purpose lanes.

The black boxes with arrows and X’s signify the LUCS, which will be spaced so that the PTS Use Lane user can visually see two LUCS at all times. In some locations, there are two cameras facing in opposite directions on the same pole for overlapping coverage such as under a bridge where a single camera will have difficulty detecting. In some limited cases, not presented in Figure 2.2, where we are proposing poles with two cameras pointing in opposite directions, any potential gap in coverage would be addressed by providing AID coverage from the side of the road. However, the design intent of this system is to provide the majority of these cameras in the median, as that is the most cost-effective layout for AID coverage.



- ① - Automated Incident Detection Camera (AID)
- ② - Lane Use Control Signal (LUCS)
- ③ - CCTV Camera
- ④ - Variable Advisory Speed Sign (VASS)
- ⑤ - ITS Cabinet
- ⑥ - ITS Cabinet maintenance pull-off

Figure 2-3: Proposed ITS Implementation Layout

Since the hardware and software are major operational and cost factors directly affecting the PTS installation limits, the following describes the ITS components of the proposed PTS operational systems included throughout the proposed PTS limits:

✓ **ATM (Active Traffic Management System):** ActiveITS will be the central software deployed to manage the PTS Use Lane System and subsystems, with the lone exception being the CCTV cameras. It fully integrates with the CHART ATMS and allows the Statewide Operations Center (SOC) operators to monitor the PTS system through a familiar platform. The ATM is the dynamic point for reducing recurring/nonrecurring congestion along the corridor in the short and long term. ActiveITS can use 44 functions, allowing for a 100% dynamically-operated roadway in the future.

✓ **LUCS (Lane Use Control Signals)** are overhead sign structure-mounted or mast arm-mounted LED signals overhang the PTS Use Lanes. In conformance with FHWA guidance each LUCS are a full matrix sign that display *Yellow X*, *Red X*, and *Green* ↓ to communicate the PTS Use Lane’s status. The signals contain LED drivers and are controlled by Advanced Traffic Controllers, which will be housed in the adjacent cabinets per **ATC #21** and **PTC #11**, respectively. Housing the controllers in the roadside boxes vs. in the signal boxes themselves allows for more efficient and safer maintenance.



In our current design the lane signals are spaced between 2,300-ft., the maximum outlined in MUTCD, and 640-ft. along the PTS Use Lane per direction, however, the spacing is ultimately determined by the motorist’s ability to see two LUCS at any time per the RFP, adjusting for visual obstruction and geometric constraints, such as bridges, curves, and signs while not exceeding the FHWA maximum.



✓ **Advanced Traffic Controllers** are mounted within the roadside ITS cabinet and control the LUCS overhanging the shoulder lane per **PTC #11**. They are identical to the shelf-mounted controllers currently used by MDOT SHA – Office of Traffic and Safety (OOTS) to operate Maryland’s signalized intersections. These operate based on predetermined time frames, but contain the input logic to be overridden by the SOC operator at a moment’s notice due to unanticipated situations, such as crashes, congestion, etc. Each roadside cabinet will also have a pull-off area adjacent to it for ease of maintenance. By locating the Advanced Traffic Controllers in the protected roadside cabinets, maintenance crews will spend less time working on the roadway within temporary lane or shoulder closures.

✓ **AID/VDS (Automatic Incident Detection/Vehicle Detection Systems)** are pole-mounted cameras approximately 40-ft. above the traveled roadway. They monitor the PTS Use Lane for incidents (AID) and travel lanes for pertinent vehicle data (VDS). These cameras cover 100% of the PTS Use Lanes and approximately 65% to 75% of the standard general-purpose travel lanes, so additional AID coverage will be programmed to cover high crash locations and decrease non-recurring congestion by cutting response times. Housing access points to these detectors in the roadside cabinets vs. in the unit themselves allows for more efficient and safer maintenance **These cameras operate 24/7 – not just when the PTS Use Lane is active and are available for CHART operators to monitor the full 30 miles of roadway having PTS.**

Our selected FLIR AID/VDS cameras will be deployed approximately every 640-ft. along the PTS USE LANE, covering both directions of the shoulder use system.

✓ **Variable Advisory Speed Signs (VASS)** are implemented to smooth traffic at the beginning and end of the PTS Use Lane

to prevent bottlenecks and at anticipated locations of increased congestion to smooth traffic flow. **Figure 2.3A** shows the locations of the proposed VASS Zones. This implementation is also known as **speed harmonization**. Within the limits of the VASS Zones, the VASS will be mounted on both sides of the roadway and operate both the PTS Use Lane (when the PTS Use Lane is in operation), as well the general-purpose lane. The VASS are controlled by the ATM, which monitors data produced by the VDS to determine if an advisory speed limit is required separate from the regulatory posted speed limit.

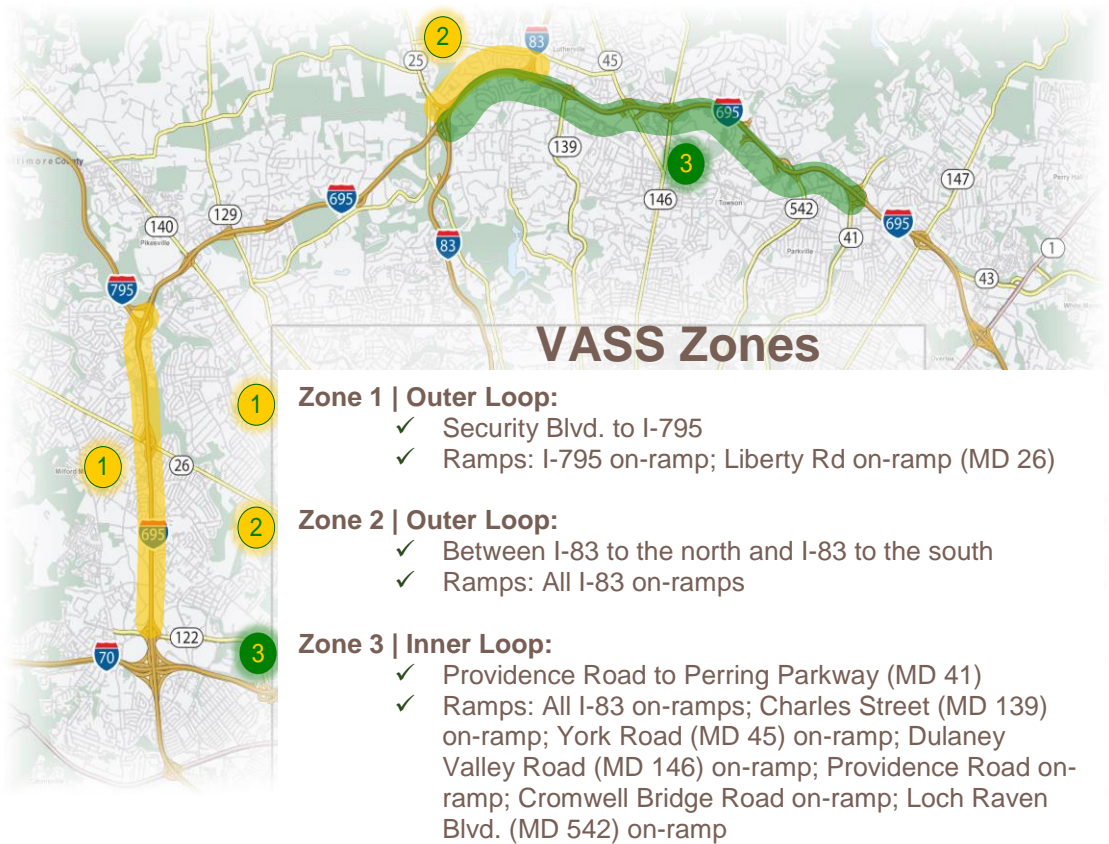

Figure 2-3A: VASS zone locations



- ✓ **CCTV Cameras** are mounted to camera poles, with lowering devices, supplementing existing camera coverage providing full CCTV coverage of the PTS Use Lane section. These are separate from any detector cameras and possess Pan-Tilt-Zoom (PTZ) functionality, nearly 360° viewing range. However, to ensure multiple views are available when needed, our proposal adds additional CCTV cameras, with Pan-Tilt-Zoom functionality, within the PTS Use Lane section for an ultimate average spacing of **0.51 miles** (double FHWA recommended density of one per mile and a 40% increase over RFP requirements of 0.85 miles).

The components and system layout that make up the dynamic operation of the PTS Use System have been thoroughly vetted for maximum reliability and efficiency, allowing MDOT SHA to receive a cost-effective system without compromising on quality. The general ITS layout was applied to the limits recommended by the VISSM model, balancing cost, mobility and other potential impacts.

Benefits of Proposed PTS Use Lane Limits: The benefits of the Corman Kokosing Team's implementation of PTS Use Lanes are shown to be substantial. There are many benefits which ultimately answer the question on why these limits were selected. The following are substantial benefits in **mobility, safety, and reliability**:

- ✓ **Mobility Benefits: Travel Time:** The most important Measure of Effectiveness (MOE) is travel time of the corridor from IS-70 to MD 43. Travel time encompasses the other MOEs, such as average speed and density, and is a direct numerical representation of the motorist's experience. It includes potential speed reductions at interchanges and lane reductions. It incorporates lane imbalances and traffic volume differences in areas between major interchanges, such as in the IS-83 weave segment. Most importantly, it can be easily explained to the general public and is a primary performance measure to assess MDOT SHA's success in managing this facility.

2040 Results: In 2040 our proposed solution reduces travel time, when compared to No-build conditions, by **34%** and **55%** on the inner and outer loop, respectively. This means it will take an average of approximately **half the time** (compared to the no-build in 2040) to travel from one end of the corridor to the other, during the time periods of peak use.

Throughput: While Travel Time is the most important MOE to describe the motorist experience, throughput is a measure of the number of motorists who get to experience the reduced travel time. It is measured as a weighted average of data collection points at select locations throughout the model of the corridor from IS-70 to MD 43. Because each of these data collection points represent a segment of modeled roadway and each segment is calculated as a throughput per length of that segment. The combination of each segment's weighted average results in the average throughput for the entire corridor, considering that some areas have higher throughput while some have lower.

2040 Results: In 2040, because of our PTS implementation approximately **2,800** additional vehicles per peak hour travel the corridor when compared to the No-Build. While motorists take less time to travel through the corridor, almost **15%** more motorists can take advantage of that savings along the outer loop alone due to the PTS implementation.

This means that more users can travel the corridor and do it in less time.

Opening Day Comparison: The above information summarizes the relief Maryland commuters will experience 20 years from now. On opening day, the benefits are significant as well. **Table 2-2** shows this analysis and compares the PTS improvements, as well as our full project, against the existing model.

Our analysis shows free flow speed is achieved for a majority of the corridor during the AM/PM peak on Day One of full implementation. Being able to travel on the outer loop from one end of the corridor to the other during peak periods, in less than 30 minutes, is something motorists have not been able to do for many years.



Our analysis shows free flow speed is achieved for a majority of the corridor during the AM/PM peak on Day One of full implementation. Being able to travel on the Outer Loop from one end of the corridor to the other during peak periods, in less than 30 minutes, is something motorists have not been able to do for many years.

✓ **Safety Benefits:** The limits of the Corman Kokosing Team’s proposed PTS Use Lane limits were selected to ensure the maximum safety benefit was realized within the corridor. As presented in FHWA’s *Use of Freeway Shoulders for Travel*, PTS implementation alone will decrease the crash rate in most installations due to the reduction in congestion and congestion-related crashes as it relates to the increase in throughput.

Additionally, our implementation limits extend through several significant crash hot spots. **Figure 2-4 (See page 9)** is a heat map showing where the majority of crashes are occurring. As expected, crashes increase at interchanges and with our PTS implementation extending through the majority of the interchanges within the corridor, the decreased density within the general-purpose lanes, and friction between general-purpose lanes and merging traffic will improve safety significantly. We also noticed a significant increase in crashes within the IS-795 and IS-83 Interchange areas. We ensured these locations were to be included in our limits as well.

In an effort to further improve safety throughout the corridor, the Corman Kokosing Team has selected high crash areas to upgrade the interchange lighting infrastructure and to provide enhanced photometrics along the traveled roadway and PTS Use Lanes. These lighting upgrades will pair well with MDOT SHA’s implementation of ASTM Type XI sheeting on overhead signs, and high reflectivity pavement markings, providing motorists with ultra-retroreflective messages and lane demarcations, decreasing crash frequencies related to poor visibility and lane drift.

Opening Day Measures of Effectiveness - Total PTS length, Travel Time and Density						
Inner Loop						
Measures of Effectiveness (MOE) for PM Peak Hour						
Scenario	Length of PTS (miles)	PTS % of Total Possible	Peak Hour Travel Time PM	% Decrease in TT (from No-Build)	PM	% increase in Avg Throughput
Existing 2018			42.5		6,839	
Proposed 2018	15	80.5%	35.0	18%	7,032	3%
Outer Loop						
Existing 2018			36.6		6,799	
Proposed 2018	15	80.5%	24.8	32%	6,776	0%

Percent decrease or increase calculated from Existing to Proposed

Table 2-2: Opening Day Measures of Effectiveness



Figure 2-4: Crash Heat Map

Safety of the PTS Use Lane itself is also a major concern. Knowing when it can or cannot be opened due to an obstacle in the shoulder is critical.

Our proposed ITS is designed to monitor the PTS Use Lanes while open and closed. The system uses the detection capability and frequent spacing of AID cameras designed to support the safe operation of the PTS Use Lane. AID cameras can detect objects in the road (100% in the PTS Use Lanes and an additional 65% to 75% of the general-purpose lanes), such as pedestrians, animals, objects, and vehicles that may prevent opening the PTS Use Lane. Prior to opening the PTS Use Lane, whether it is on a static schedule or operating dynamically, a verification process must be followed to ensure there are no hazards that would prevent using the lane. Basic steps to prepare to open are:

1. Verify there are no alarms from AID cameras
2. Visually confirm there are no objects, obstacles, or incidents in the PTS Use Lane using the expanded CCTV coverage.

Reliability Benefits: Under normal peak-period conditions with the PTS Use Lane open, the roadway is less likely to be congested, so the risk of non-recurring congestion is reduced. By maximizing the PTS Use Lane’s length, we minimize the risk of non-recurring congestion, making the corridor more reliable, because of variations in traffic volumes, weather conditions, and/or crashes, which are the main causes of congestion.

Measuring the travel time reliability provides an indication of how much variation there is in the MOEs reported. MOEs represent an average of how well the system performs but does little to indicate variation in that performance from day to day.



That variation can be measured in terms of standard deviation in travel time. Variations occur with multiple runs of the model. Random seed numbers modify model parameters slightly to deliberately simulate this variation. As a result, some runs provide a better travel time than others, even though the design of the road is unchanged. Based on these travel times for each run, a standard deviation is calculated. The higher the standard deviation, the less reliable the corridor is likely to be in terms of travel time from one day to the next. For example, in the No-build 2040 for the Outer Loop, the standard deviation is 16.5 minutes in the AM peak hour. That means that there is approximately a 68% chance that a motorist’s travel time will be between 219.1 and 252.1 minutes of overall travel time, 16.5 minutes, plus or minus.

Our design for the same scenario has a standard deviation of 4.5 minutes, or approximately a 68% chance that a motorist’s travel time will be between 86.0 and 95.0 minutes of overall travel time; obviously, a significantly more reliable commute.

Our project is designed to detect and verify non-recurring congestion along IS-695 within the limits of our PTS Use Lane using a combination of cameras, sensors, and detectors placed overhead and along the roadside. This equipment quickly detects the occurrence of an incident by monitoring the prevailing traffic conditions and proactively identifying changes compared to historic or previously measured conditions.

PTS Use Lane Typical Section: In this sub-section, we will review the typical section the Corman Kokosing Team proposes for the static-dynamic median part-time shoulder use and the process we followed to select the typical section and locations. A discussion of the proposed features that do not meet or exceed the roadway design and safety guidelines referenced in TC 3.08 is included, as well as justification for their use. Also described are the benefits that will be realized by MDOT SHA and motorists by using this typical section.

The Typical Section: The Corman Kokosing Team’s PTS Use Lane design was developed in accordance with design considerations established in the FHWA publication *Use of Freeway Shoulders for Travel*, February 2016 in conjunction with AASHTO’s *A Policy on Geometric Design of Highways and Streets*, 7th Edition, 2018 and *A Policy on Design Standards – Interstate System*, 2016.

PTS Use Lane/Median Shoulder Width (ATC #1): MDOT SHA’s RFP and most design guidance requires a 14-ft. PTS section, 12-ft. PTS Use Lane, plus a 2-ft. offset. The Corman Kokosing Team implemented this section in areas where the existing median shoulder was 14-ft. wide or greater. In many locations along the corridor, the available shoulder width narrows, and the desired 14-ft. wide PTS Use Lane section cannot fit within the existing shoulder width.

We proposed through conditionally-approved **ATC #1** to use a minimum width PTS section of 12-ft., providing an 11-ft. wide PTS Use Lane with a minimum 1-ft. lateral offset to the concrete median barrier. An 11-ft. PTS Use Lane is acceptable based on FHWA’s design guidance and has been safely implemented in other states. However, a Design Exception is required and will be requested for the reduced lane width.

The proposed PTS Use Lane Typical Section is shown in **Figure 2-5** below. The approximate locations within our proposed limits where this PTS Use Lane width will be used, are identified in **Table 2-3** and are subject to refinement as the design progresses. In all other locations, the full 14-ft. width PTS will be used.

	START	STOP	START	STOP
DIRECTION	LOCATION	LOCATION	MP	MP
Inner and Outer Loop	Liberty Road	Stevenson Road	10.2	14.2
Inner and Outer Loop	W. Joppa Road Overpass	Cromwell Bridge Road	17.4	22.8

Table 2-3: Approximate locations of 11-ft. + 1-ft. PTS Use Lane

General-Purpose Lane Width (ATC #5R1): The Corman Kokosing Team proposes 12-ft. general-purpose lanes to the maximum extent practicable within the project limits. However, our analysis shows there are numerous locations along the corridor where the inside shoulder width is inadequate for implementation of the conditionally-approved reduced PTS Use Lane width of 11-ft., plus 1-ft. median barrier offset.



Our approach to the PTS Use Lane design is for every 0.5-ft. we need to widen the existing interior shoulder to provide for the required PTS Use Lane, we would start by reducing the PTS Use Lane and offset width, as described in **ATC #1**, then reducing general-purpose lanes from the existing 12-ft. lane widths to 11.5-ft. lane widths, starting with the inside general-purpose lane and moving out towards the outside shoulder as needed. This is depicted in **Figure 2-5** where you can see the on the left side only two lanes needed reduction; while on the right side all lanes were reduced due to a wider median.

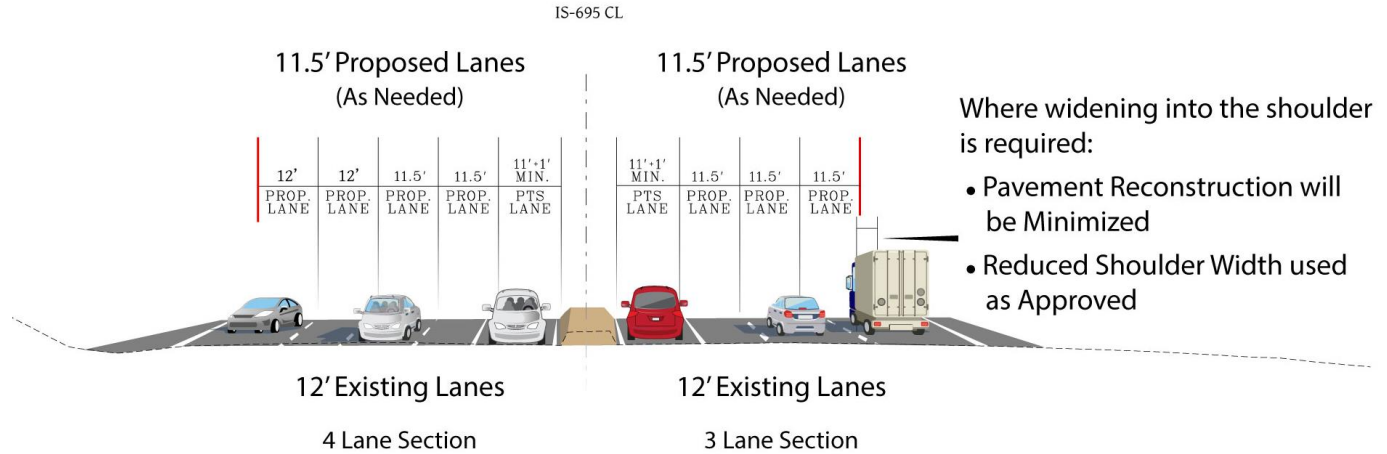

Figure 2-5: Existing vs. Proposed PTS typical section

This strategy will also be implemented at pinch points where existing bridge abutments, sign structures, proposed LUCS poles, etc. constrain the existing width of the IS-695 section. The use of **ATC #1** will prevent significant widening, impacts to structures, minimize impacts to environmental resources, and reduce stormwater management requirements. A design exception for the deficient general-purpose lane widths will be prepared during final design for approval at all locations the 11.5 ft. lane width is to be used.

Outside Shoulder (ATC #6R2): Full 10-ft. outside shoulders are to be used across the clear majority of our PTS implementation limits, with only a few exceptions that were conditionally approved through **ATC #6R2**. The use of a reduced shoulder width is shown on the right side of **Figure 2-5**. The locations identified and the proposed reduced shoulder width are outlined in **Table 2-4**:

LOCATION NO.	DIRECTION	*START MM	*STOP MM	*LENGTH	*PROPOSED MIN. PAVED SHOULDER WIDTH	EXISTING PAVED SHOULDER WIDTH
1	Outer Loop	23.26	23.33	200-ft.	8-ft.-9-in.	12-ft.
2	Outer Loop	24.50	24.55	300-ft.	8-ft.-6-in.	10-ft.
3	Outer Loop	28.70	28.83	420-ft.	8-ft.-9-in.	9-ft. to 11-ft.
4	Outer Loop	29.30	29.40	460-ft.	9-ft.-5-in.	10-ft. to 11-ft.
5	Outer Loop	31.12	31.16	250-ft.	7-ft.-6-in.	9-ft. to 13.5-ft.

**Mile marker locations, lengths and proposed widths are approximate and will be finalized during design.*

Table 2-4: Reduced shoulder width locations

Also, MDOT SHA provided conditional approval through this ATC to minimize outside shoulder widths at specific curves where widening is required to mitigate HSSD concerns in the PTS Use Lanes. During final design, we will evaluate the need to reduce



outside shoulder width and minimally implement as such, with approval from MDOT SHA. All locations of substandard outside shoulder width will require approval through a design exception as well.

Process for Selecting the Typical Section: The PTS Use Lane design follows an *Order of Importance* strategy whereby geometrics of the mainline typical section will change, depending on the extent of the existing constraints to accommodate the PTS Use Lane. **Table 2-5** outlines the process the Corman Kokosing Team followed to identify what elements of the typical section would narrow and where:

ORDER OF IMPORTANCE

Step 1	Narrow PTS Use Lane from 12-ft to 11-ft. and narrow the PTS median barrier offset from 2-ft. to 1-ft.	ATC #1: Conditionally Approved
Step 2	Narrow each successive general-purpose lane to 11.5-ft. only as required to avoid outside shoulder impacts.	ATC #5R1: Conditionally Approved
Step 3	Shift to the outside and reduce the outside shoulder width.	ATC #6R2: Conditionally Approved
Step 4	Widen the roadway and outside shoulder	No ATC required

Table 2-5: Order of importance

This is a Practical Design approach to the project. MDOT’s Practical Design Policy states that the design of a project should be reviewed to ensure it best aligns with its purpose and need, without sacrificing safety. While these reductions will require Design Exceptions (with the exception of Step 4), we are confident these are safe reductions to the typical section to better meet the goals of this project. A full safety analysis will be performed during final design to justify the required design exceptions.

Other Key Issues and Design Considerations: Other key issues were analyzed/reviewed for the proposed PTS Use Lane limits to assist in selecting the typical section. Part of our evaluation was to determine how our implementation limits and typical section affected the key issues identified in the RFP, as well as other factors we considered:

✓ **Noise:** We performed a preliminary noise analysis of the entire project limits to evaluate the potential for impacts from implementation of PTS Use Lane. As described in the typical section discussion above, our proposed solution involves shifting lanes to the outside, closer to noise sensitive areas. Thus, our proposed improvements meet the definition of a Type I Project per MDOT SHA Noise Policy and 23 CFR 772.5.

Our preliminary findings determined that only two existing noise barriers would likely need extended/raised/relocated. For example, to address a HSSD issue at Curve #2 where we are extending grading close to an existing noise barrier, we will develop a plan to avoid replacing the noise barrier (assuming the noise analysis does not require increased height, in which case reconstruction may be required).

✓ **Pinch Points:** Existing/proposed pinch points were evaluated throughout the entire corridor. In many areas, we mitigate the constraint by implementing the geometric ATCs noted above. Other locations involve lane shifts to provide adequate width for the PTS Use Lane.

✓ **Shoulder Geometry:** As noted, the existing shoulders were not designed for full traffic loading. We evaluated the PTS geometrics to meet AASHTO Standards and with respect to controlling criteria as follows:

- **Design Speed:** The PTS Use Lane meets the 55-mph design speed
- **Horizontal Curve Radius:** No violations of minimum curve radii for the design speed
- **Super-elevation Rate:** Our PTS Use Lane matches the super-elevation of the existing roadway, which meets AASHTO even with a slightly smaller radii due to the PTS Use Lane on the interior of turns
- **HSSD:** Analysis performed and required accommodations implemented
- **Vertical Clearance:** Analysis performed and existing vertical clearance issues were discovered at the Park Heights Avenue underpass. Our design will maintain the existing bridge clearance at this location. (A design exception may be required.)
- **Maximum Grade:** Matches existing

- **Cross Slope:** Meets AASHTO minimum as required by the RFP
 - **Design Loading Structural Capacity:** Pavement Design meets RFP criteria, and where it does not new pavement will be provided.
- ✓ **Pavement Condition:** Using the data provided from MDOT SHA, along with the RFP, the Corman Kokosing Team analyzed the pavement thicknesses and conditions throughout the PTS Use Lane limits. Multiple locations of the inside and outside shoulders have been identified and included in our concept for patching, rehabilitation, or reconstruction due to condition or insufficient structural capacity for traffic loading.
- ✓ **Right-of-Way (ROW):** The Corman Kokosing Team knows the concerns related to property acquisition and the inability to obtain additional ROW for this project. Taking this into consideration, all proposed improvements are within existing SHA ROW.
- ✓ **Environmental Resources:** The Corman Kokosing Team minimized/avoided impacts to environmental resources. Although we anticipate some minor impacts to Waters of the US (WUS) and forested areas, we will continue to refine the design to eliminate/reduce impacts. Anticipated noise impacts are also minor, likely requiring noise barrier extensions at two locations. Minor impacts are expected to wetlands, while no impacts are expected to historic properties, cultural resources, threatened/endangered species, or other environmental resources. All impacts will be mitigated in accordance with current regulations and requirements
- ✓ **Maintenance:** After construction, maintenance of the facility is critically important. MDOT SHA will need to maintain the existing roadway elements, as well as all proposed elements. The Corman Kokosing Team reviewed the PTS Use Lane implementation to ensure that structures can continue to be inspected, maintenance activities can continue unabated (including snow plowing and mowing operations) and ITS equipment - existing and proposed - can be accessed and maintained as necessary.
- The Advanced Traffic Controllers for the AID and LUCS systems in the median have been moved to the roadside cabinets along the right shoulder for ease and safety of maintenance. Additionally, **warranties on the provided ITS hardware have been extended to five total years**, decreasing the reliance on stock materials provided as part of this project to keep the dynamic PTS Use Lane operating.
- ✓ **Traffic Barrier Standards:** The existing median barrier along the IS-695 corridor was constructed and reconstructed at various times. The Corman Kokosing Team reviewed the height, width, and type of barrier throughout the corridor and made adjustments to address any substandard locations. We define two innovative approaches to addressing these issues in the following sub-section.

Features of the Typical Section not meeting RFP Requirements: Use of the existing shoulder along a freeway in itself does not meet AASHTO requirements. When the PTS Use Lane is in operation, the median shoulder is no longer available to the general-purpose lanes and requires a design exception since full shoulders on both sides of the highway are required. That being said, the additional capacity offered by the PTS Use Lane typically supersedes its use as a shoulder during those times of the day.

In addition to the general Design Exception needed for the PTS Use Lane, and as discussed above, the Corman Kokosing Team's Typical Section also reduces PTS Use Lane width, the general-purpose lane width, and the outside shoulder width in select locations. While not preferred, the following presented the justification for reducing these elements:

- ✓ **Safety Analysis of Reduced Lane and Shoulder Widths:** FHWA study findings show that minor reductions in lane width have only slightly higher frequency of crashes, while overall crash rates decrease due to the reduction in congestion and increase in traffic volumes achieved. FHWA's *Use of Narrow Lanes and Shoulders on Freeways Guide* states "the greater the average daily traffic – and presumably the greater level of congestion during the "before" condition – the more likely that the safety benefits from reduced congestion will outweigh the potential safety issues associated with narrower lanes and shoulders."

IS-695 within the project limits is a perfect candidate to meet these characteristics. Annual Average Weekday Traffic (AAWDT) ranges from 150,000 to almost 230,000 vehicles, while the percentage of the corridor with a level of service (LOS) that is failing (LOS E/F) is approaches 75% in the AM and 50% in the PM. This project will see safety benefits from reduced congestion outweighing potential safety issues associated with slightly narrower lanes and shoulders.

Further research in FHWA's *Use of Freeway Shoulders for Travel Guide* demonstrates that implementing PTS Use Lane alone would likely reduce congestion-related crashes during the hours of PTS Use Lane operations, reduce property damage-only crashes, and with little to no effect on fatality and injury crashes for eight-lane highways when an analysis was performed using the Highway Safety Manual. As MDOT SHA requested in multiple ATC responses, the Corman Kokosing Team will comply with the applicable results of a full safety analysis during final design, to justify any required Design Exceptions.

- ✓ **Traffic Operations Analysis of Reduced Land and Shoulder Widths:** Traffic Operations impacts are also anticipated to be minor when using the proposed reduction in lane and shoulder widths. The Highway Capacity Manual (HCM) shows expected reductions in Free Flow Speed (FFS) due to reduced lane and shoulder widths. HCM, Exhibit 11-8 shows one can expect a reduction of 1.9 mph using 11-ft. lanes (while the PTS Use Lane is the only 11-ft. lane, conservatively, it would be applied to all lanes through the HCM), and HCM Exhibit 11-9 shows the reduction in lateral clearance (shoulder width) down to 1-ft. for a four-lane highway (one direction) would be about 1 mph. Exhibit 11-9 is based on right-side lateral clearance, but it can be assumed that the effect of left-side lateral clearance on FFS would be less.

Based on this information and taking the conservative approach of applying the right-side clearance FFS reduction to the median side, it can be expected there would only be about a 3-mph reduction in FFS for 11-ft. lane widths with a 1-ft. median offset. The HCM analysis cannot apply to just one lane, so the 11-ft widths are assumed for all lanes, including the general purpose, even though the general-purpose lanes are proposed to be wider (minimum 11.5-ft.).

CONCLUSION

Several key design manuals and guidelines from credible sources show that using narrower lanes and shoulders (11-ft. PTS Use Lane; 11.5-ft. general purpose), 1-ft PTS offset, and reduced outside shoulder as we propose have minor impacts on roadway safety and operations.

To maximize the length of PTS Use Lane within the project limits, we proposed the minor geometric modifications through the conditionally-approved ATCs. They reduce potential impacts to structures, environmental features, culverts, sign structures, ITS devices, utilities, SWM facilities, and other roadside features associated with roadway widening. Finally, these benefits of PTS Use Lane implementation far outweigh the minimal impacts to FFS. These geometric modifications are an example of Practical Design as the project's goals are to maximize the length of the PTS Use Lane, improve mobility, improve safety, and provide for a maintainable, operable, adaptable corridor.

Other Features not Meeting RFP Requirements: The following elements of the Corman Kokosing Team's proposed improvements do not meet or exceed the design guidelines referenced in TC 3.08, but have been conditionally approved for use through the ATC process. While their use may not meet typical design guidance, these are safe and innovative implementations of non-standard interstate design elements:

- ✓ **Drainage:** A safe implementation of the PTS Use Lane in the existing median shoulder area requires addressing drainage spread to avoid traffic safety issues during storm events. For **ATC #42R1**, we received conditional approval to implement a drainage gutter within the concrete median barrier offset area. The existing condition along the concrete barrier is a single pavement slope terminating at the barrier edge resulting in stormwater runoff spreads extending well into the existing median shoulder area. The median drainage gutter provides a significant decrease to the anticipated spread condition by creating a shallow gutter to convey drainage runoff to the next inlet downstream. This allows the PTS Use Lane to be constructed within 1-ft. of the existing concrete median barrier while reducing drainage inlets needed to meet MDOT SHA drainage spread requirements.

✓ **Concrete Barrier Modifications:** The Corman Kokosing Team 's innovative approach to modifying the barrier also relieved safety concerns while increasing the benefit-cost ratio. By avoiding the need to reconstruct the median barrier whenever the barrier height was reduced below MDOT SHA standards, we knew there would be significant savings. Two ATCs were submitted and conditionally approved:

- **ATC #25R1:** Provides a detail for extending the barrier height a maximum of 6-in. to meet height requirements.

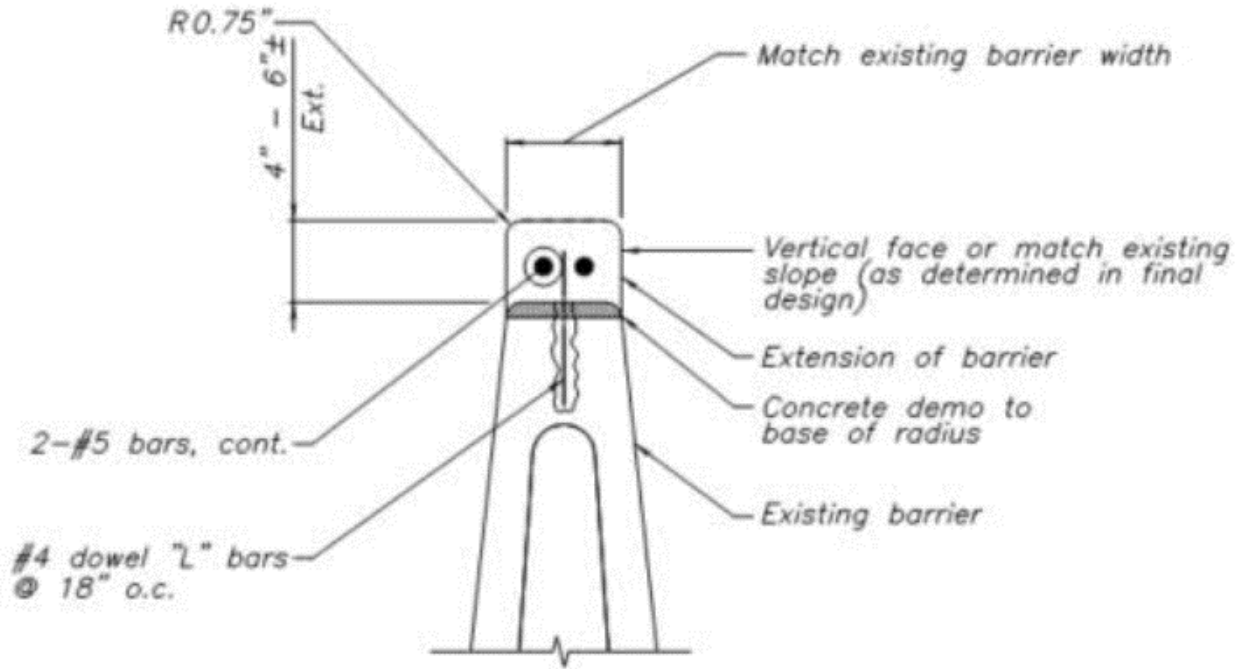

Figure 2-6: ATC 25R1

- **ATC 26R1:** Provides a detail for encapsulating the existing barrier within a single slope barrier.

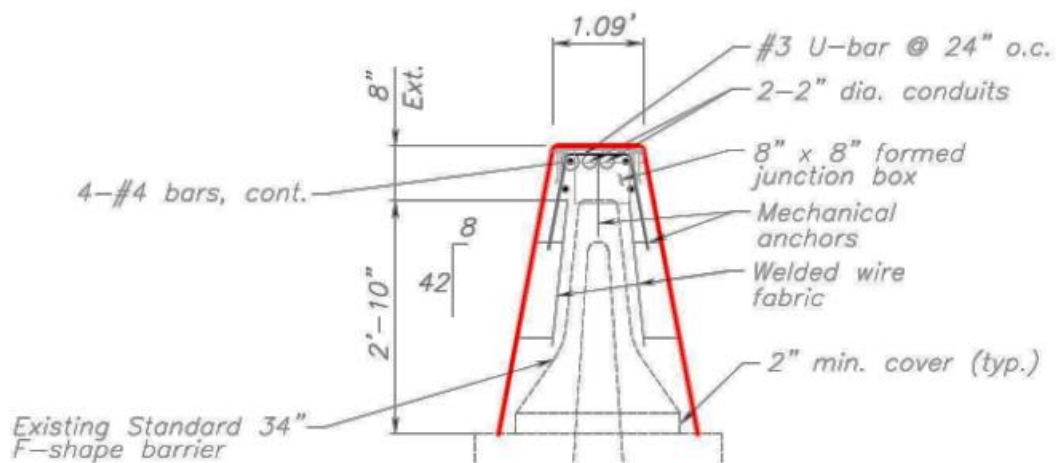

Figure 2-7: ATC 26R1



Using these ATCs minimizes the removal/reconstruction of concrete median barrier required, minimizes construction duration and simplifies maintenance of traffic (MOT), allowing the Corman Kokosing Team to reduce median shoulder closures and traveling public impacts.

ii. Discuss how our static-dynamic median part-time shoulder improvements will reduce recurring congestion in terms of travel time, vehicle throughput, density, intersection operations, queues and vehicle network performance, along the IS-695 Outer Loop and Inner Loop and on the connecting ramps and arterial roadways

By providing a static-dynamic PTS Use Lane within the Corman Kokosing Team's proposed limits along both directions of IS-695, recurring congestion is reduced through additional capacity focused on when it is needed most. Instead of providing additional capacity at all times, which would impact traffic growth trends differently, the PTS improvements provide additional roadway capacity during peak periods, and other times as needed and initiated by MDOT SHA. By using a dynamic, intelligent transportation scheme that opens the lane during congestion, MDOT SHA has total control to mitigate recurring/non-recurring congestion.

Corman Kokosing Team's Improvements will:

- ✓ Add **30 total miles** of new PTS Use Lane (80.5% of the project limits)
- ✓ Reduce travel times up to 55%
- ✓ Increase throughput up to 42%
- ✓ Reduce density up to 38%

The Corman Kokosing Team's proposed limits of implementation are both Inner and Outer Loop from IS-70 to Cromwell Bridge Road for a total length of 30 miles.

By default, on weekdays, the PTS Use Lane operates on a time-of-day schedule based on historical hourly traffic trends. When in use, traffic travels at higher speeds than under existing peak-period conditions, thus reducing travel times. By minimizing the severity of recurring congestion, which is defined by duration/length of queueing, throughput is increased since latent demand decreases. In turn, the density reduces to a point that reflects on maximized throughput. **Table 2-6 (See page 18)** shows the anticipated benefits and reduction in recurring congestion, for PTS Improvements.

Travel Time Improvements: As shown in **Table 2-6**, travel time benefits along IS-695 within the project limits for implementing the PTS Use Lanes are significant. The Inner Loop realizes a 34% reduction in Travel Time while the Outer Loop has a 55% reduction. This means that for the majority of trips, one can expect to cut their travel time through the corridor by more than half, when compared to the No-Build.

Vehicle Throughput: Throughput has similar benefits with implementation of our PTS strategy. In 2040, there is a total of approximately 2,800 additional vehicles per peak hour with the PTS Use Lane in place. **That is approximately a 42% increase along the Outer Loop and a 17% increase on the Inner Loop over the No-Build option.**

Density: After adding PTS Use Lanes within the limits proposed by the Corman Kokosing Team, traffic density (vehicles/mile) during peak periods reduces significantly. As shown in **Table 2-6**, an almost 38% decrease in density along the Outer Loop and 26% decrease on the Inner Loop.



Measures of Effectiveness -Total PTS length, Travel Time, Throughput, and Density											
Inner Loop											
Measures of Effectiveness (MOE) for Peak Hour (8:00-9:00 AM and 4:00-5:00 PM)											
Scenario	Length of PTS (miles)	PTS % of Total Possible	Average Peak Hour Travel Time (min)		% Decrease in TT (from No-Build)	Average Peak Hour Throughput (pc/hr)		% increase in Avg Throughput	Average Peak Hour Density (pc/ln/mi)		% Decrease in Avg Density
			AM	PM		AM	PM		AM	PM	
Existing 2018			31.5	42.5		6,607	6,839		40.1	47.2	
No-Build 2040			74.3	133.5		5,938	5,267		80.0	104.6	
Proposed 2040	15	80.5%	45.9	91.4	34%	6,952	6,213	17%	57.4	78.8	26%
Outer Loop											
Existing 2018			57.5	36.6		6,529	6,799		65.5	43.9	
No-Build 2040			235.6	166.6		4,012	4,655		146.5	131.9	
Proposed 2040	15	80.5%	90.5	92.0	55%	6,414	5,927	42%	89.8	83.5	38%

Percent decrease or increase calculated from No-build to Proposed

Table 2-6: Anticipated benefits and reduction in recurring congestion

Effect on Arterials, Ramps and the Surrounding Road Network: Under existing conditions, when there is recurring congestion along the mainline, on-ramp traffic cannot enter IS-695 smoothly, resulting in queuing and delays along the ramps and often, on the intersecting arterial roadways. With improved throughput and travel speeds, ramp traffic merges onto the mainline more efficiently due to the available capacity on the mainline. As traffic patterns become more favorable along the on-ramps, intersecting arterials realize secondary benefits with traffic headed for IS-695 being more likely to clear intersections and ramp diverge points with less delay. Any previous spill-back issues that impact other parts of the road network will realize similar benefits. Our design significantly improves density and LOS of the merge, diverge, and weave areas of associated ramps, especially within the area with PTS Use Lane. Many ramp areas also have an increase in volume, which means that even in areas where density or LOS does not improve, more motorists can use the facility, providing more mobility to more motorists.

Recurring congestion on IS-695 under existing conditions can often result in motorists using alternate routes, increasing demand and delays along off-ramps and connecting arterials. With the PTS Use Lanes in operation during peak periods, more traffic will stay on IS-695 due to improved throughput and travel times, thus reducing workaround traffic demand on alternate routes. This leaves the off-ramps, intersections, and surrounding roadway network with more reserve capacity to handle traffic not destined to/from IS-695.

ITS Implementation: The system will be built with ITS devices, such as LUCS, to clarify when the lane is open to traffic, even though signs will notify them of the PTS Use Lane’s typical operating hours. LUCS availability allows MDOT SHA CHART staff monitoring the corridor to open the PTS Use Lane earlier than the typical peak period if congestion builds up faster than normal. On the flip side, if congestion lingers beyond the typical end of the peak period, CHART staff can keep the lane open to traffic until higher prevailing speeds are achieved.

The full project, including detection cameras, will have fully-integrated communications where the detectors can calculate speed and communicate with the system to change the PTS Use Lane’s open/closed condition when speeds either increase or decrease to a programmed threshold. Although recurring congestion is defined as such due to typical daily patterns, the severity is different every day, as indicated by several travel time reliability metrics.

Since the Travel Time Index along several sections of the corridor are above 1.0, congestion levels vary; even recurring congestion. Having a system that can make slight real time alterations in PTS Use Lane operation hours maximizes the value of the lane as congestion times vary approaching the start of the peak period and dissipate at varying times approaching the end of the peak period.



The system not only serves to operate the PTS Use Lane and reduces recurring congestion, it will also detect incidents and assists first responders in getting to the scene and better managing traffic leading up to and through the location, and beyond the incident. This will assist in reducing incident response which improves non-recurring congestion. Because almost 50% of all incidents occur during peak travel periods, intuitively, these benefits will also reduce recurring congestion and improve reliability.

Opening Day Measures of Effectiveness - Total PTS length, Travel Time and Density						
Inner Loop						
Measures of Effectiveness (MOE) for PM Peak Hour						
Scenario	Length of PTS (miles)	PTS % of Total Possible	Peak Hour Travel Time PM	% Decrease in TT (from No-Build)	PM	% increase in Avg Throughput
Existing 2018			42.5		6,839	
Proposed 2018	15	80.5%	35.0	18%	7,032	3%
Outer Loop						
Existing 2018			36.6		6,799	
Proposed 2018	15	80.5%	24.8	32%	6,776	0%

Percent decrease or increase calculated from Existing to Proposed

Table 2-7: Opening Day MOEs

Opening Day Comparison: The above information summarizes the relief Maryland commuters will experience 20 years from now. On opening day, the benefits are significant as well. Table 2-7 shows this analysis and compares the PTS improvements against the Existing model.

Our analysis shows free flow speed is achieved for a majority of the corridor during the AM/PM peak on Day One of full implementation. Being able to travel on the outer loop from one end of the corridor to the other during peak periods, in less than 30 minutes, is something motorists have not been able to do for many years.

iii. Performance life provided by our static-dynamic median part-time shoulder use, with the Corman Kokosing-selected predetermined hours of operation; that is, the time it takes for congestion levels to return to pre-construction levels in these various locations if no modification of time of day use is made.

The Corman Kokosing Team’s implementation of PTS Use Lanes along the median of the Inner and Outer Loops of IS-695 are anticipated to be effective into and beyond the 2040 build-year. Our proposed limits of PTS Use Lanes extend from IS-70 to Cromwell Bridge Road along the Inner and Outer Loops.

Analysis of Performance Life: We conducted an evaluation to determine increase in volumes and the resulting performance measures over time. This evaluation includes Measures of Effectiveness (MOEs) for intermediate years 2025, 2030, and 2035.

To compare each year, *Travel Time, Throughput, and Density* are used to compare intermediate years performance against the existing preconstruction levels to determine the performance life of the project. Results of applying this methodology are presented in **Table 2-8 on page 20**.

Travel Time Analysis: Using the travel time MOE, the Inner Loop would return to preconstruction (2018) levels by approximately 2028 in the AM, and 2026 in the PM. The Outer Loop fares a little better, not returning to preconstruction levels until 2029 in the AM, and 2027 in the PM. That being said, when you look at the no-build, the PTS implementation saves on average 50% in travel time.

Throughput Analysis: When comparing the throughput results for intermediate years against the existing, in the AM the Outer Loop returns to preconstruction levels in approximately 2039, however, the Inner Loop never returns to preconstruction (2018) levels! The additional throughput that our PTS implementation provides almost entirely stays above the existing through and beyond 2040 during the AM peak.



The Inner and Outer Loop return to preconstruction levels in approximately 2029. When compared to the No-Build, the PTS Implementation provide 1/3 more throughput.

Density Analysis: When comparing the density results for intermediate years against the existing, the Inner Loop in the AM returns to preconstruction levels by 2029, and by 2026 in the PM. The Outer Loop does not return to preconstruction (2018) levels until 2032 in the AM, and 2027 in the PM. That being said, density is vastly improved over the no-build; almost 50%.

CONCLUSION

When looking at these results in total, it can be deduced that the Corman Kokosing Team’s implementation limits of PTS Use Lane will continue to benefit users until approximately 2030. ***That is 10 years of benefit for everyday commuters along the IS-695 corridor who will enjoy a better, faster commute.***

The Corman Kokosing Team’s installation of speed harmonization (using VASS), is an aspect that can be optimized/expanded in the future to assist in managing and extending the project’s performance life. The speed harmonization system proposed at the limits of the PTS Use Lane on the Inner and Outer Loops and for significant segments of the project corridor (approximately 14 total miles), can be further expanded cost effectively to better manage incidents, and extend ITS’s positive effects beyond the limits of the PTS Use Lanes.

Proposed - Interim Year Performance						
Inner Loop						
	Average Peak Hour Total Travel Time (min)		Average Peak Hour Throughput (pc/ln/mi)		Average Peak Hour Density (pc/mi)	
	AM	PM	AM	PM	AM	PM
Existing 2018	31.5	42.5	6,607	6,839	40.1	47.2
Proposed 2025	27.1	42.3	6,877	6,700	32.6	45.8
Proposed 2030	35.3	51.4	6,774	6,816	42.6	52.1
Proposed 2035	37.3	62.3	7,041	6,704	46.8	60.4
Proposed 2040	45.9	91.4	6,952	6,213	57.4	78.8
No-Build 2040	80.2	133.5	5,938	5,267	80.0	104.6
Outer Loop						
Existing 2018	57.5	36.6	6,529	6,799	65.5	43.9
Proposed 2025	46.5	31.5	6,763	6,910	50.0	37.7
Proposed 2030	58.8	46.8	6,769	6,721	62.8	54.9
Proposed 2035	72.7	54.1	6,725	6,471	74.7	60.1
Proposed 2040	90.5	92	6,414	5,927	89.8	83.5
No-Build 2040	235.6	166.6	4,012	4,655	146.5	131.9

Table 2-8: Interim Year Performance



MARYLAND DEPARTMENT
OF TRANSPORTATION™

STATE HIGHWAY
ADMINISTRATION

2.09.03 MOBILITY

i. Improvements, other than static-dynamic median part-time shoulder, we will provide to maximize vehicle throughput and minimize vehicle travel times

Existing traffic conditions on IS-695 inhibit mobility and reliability, has an economic impact to the region, and cost motorists valuable time. MDOT SHA has the daunting task of managing traffic conditions with limited resources and initiated this project to improve mobility, defined as travel time, throughput, and density along the corridor. A well-designed system of tools will help MDOT SHA manage the traffic flow conditions, responding to changes in traffic flow and using the system capabilities to improve mobility.

The Corman Kokosing | WSP | MC Dean Design-Build Team (Corman Kokosing Team) approach focuses on implementing a Part-Time Shoulder (PTS) Use Lane coupled with a robust, comprehensive Intelligent Transportation System (ITS). To supplement this approach, other strategies we will implement to provide greater throughput and lower travel times included the following:

Proposed Improvements:

- ✓ Added 30 total miles of new PTS Use Lane
- ✓ Reduced travel times by **55%**
- ✓ Increased throughput 42%
- ✓ Reduced density 38%
- ✓ Improved overall network performance by reducing total delay by 31%

1. **Variable Advisory Speed Zones:** Add Variable Advisory Speed Signs (VASS) in critical areas for general-purpose lanes and ramps
2. **Mitigation of PTS Use Lane Horizontal Stopping Sight Distance (HSSD):** Eliminate substandard sections of the median shoulder to provide *all* PTS Use Lane with adequate HSSD with out requiring any Design Exceptions
3. **Improvements to Monitoring Conditions Impacting Throughput and Travel Times:** Provide full-time (24/7) monitoring of throughput, speed, density, and other traffic characteristics in 65% to 75% of the general-purpose lanes, within the limits of PTS Use Lanes
4. **CCTV Cameras:** Enhanced CCTV coverage, for the entire corridor, for surveillance of roadway operation in addition to what is required by the RFP
5. **Enhanced Dynamic Message Sign (DMS) Utilization:** Enhanced utilization capability of existing DMS for VASS implementation
6. **Minimizing Impacts to Existing Conditions:** Minimize impacts to existing conditions through:
 - Maintaining functional AASHTO-compliant lane configurations/widths
 - Maintaining functional AASHTO-compliant outside shoulder width
 - Improved enhanced drainage system to meet RFP requirements;
7. **Improvements to Harford Road Acceleration Lane:** Improve Harford Road acceleration lane to improve mobility and reduce congestion.
8. **Add Additional Roadway Lighting in specific Areas of High Accident Rates:** Reduces incidents, improves incident management, and improves travel times

Each strategy plays an important role in improving overall mobility through the corridor. Our design has carefully considered all of them; whether they provide a direct improvement to mobility or they indirectly improve mobility by allowing other improvements to be provided that enhance mobility. For example, narrower general-purpose lane widths may be required to accommodate the PTS Use Lane in some locations. Our design minimizes these locations and, where necessary, provides



a lane width that is fully AASHTO compliant and remains functional as a lane. There is no compromise in mobility due to lane widths, and we have accommodated a PTS Use Lane that greatly improves mobility, making it a win-win. Each of these strategies is further detailed below:

1. **Variable Advisory Speed Zones** are proposed to provide MDOT SHA with new tools to manage the IS-695 corridor full time, seven days a week, 365 days a year. VASS post a speed dynamically based on detection input and has a direct impact to throughput and travel time of the corridor.



How it works: The VASS displays appear when conditions are atypical based on time of day, per changes in speeds and potential rolling queues. They advise motorists to reduce speed approaching and/or within congested conditions or at locations with closed lanes/shoulders. Motorists then reduce speed more gradually and consistently with each other, which reduces the frequency/extent of congestion that typically occurs with more severe deceleration over shorter distances. The result is the road provides a safer, more reliable trips, and congestion will be reduced – as measured by throughput and travel time.

VASS locations were determined based on traffic modeling to where they maximize throughput and minimize travel time. VASS are set up in three zones covering critical areas of the Inner and Outer loops (See Figure 3-1). By employing PTS Use Lanes and VASS, throughput improves by 42% in the corridor and travel time improves by 55% over No-Build.

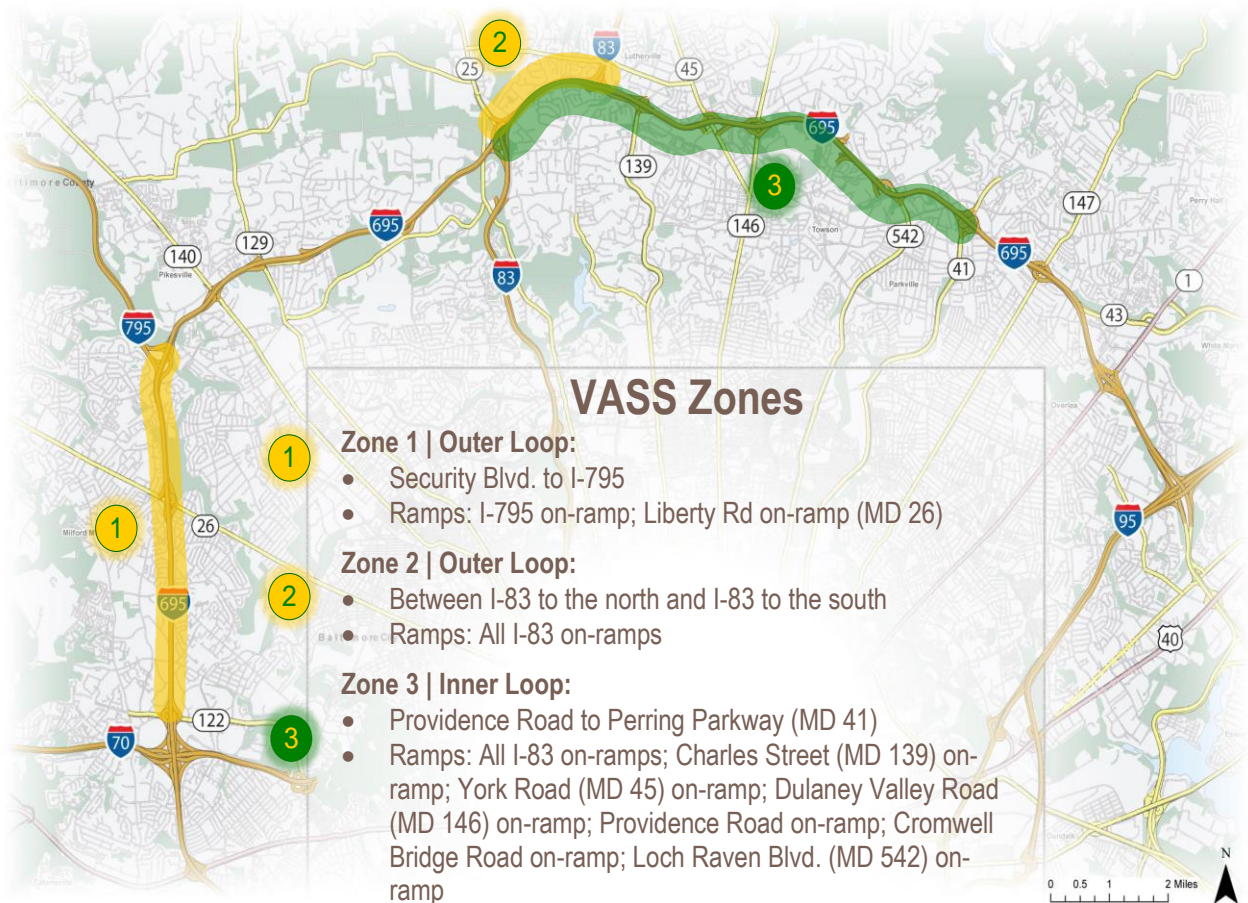

Figure 3-1: VASS Zones

Variable Advisory Speed Signs (VASS): This uses VASS in groupings through ActiveITS, MDOT SHA’s corridor Active Traffic Management System (ATMS), to provide speed advisories to motorists before approaching congestion. VASS are placed in pairs; one in the median and one on the outside with each spaced approximately ½ mile apart. Additional details are provided within **PTC #10**. Speed advisories are displayed based on real-time data from detection. The Corman Kokosing Team’s concept is to display advisory speeds of either 45-mph or 35-mph; however, our system is capable of 5-mph increments and we will work collaboratively with MDOT SHA to establish the preferred operation of the system.

As roadway congestion is detected and travel speed is reduced to a threshold, 45-mph will be displayed in pairs approaching the congested area. If congestion continues to build and reaches a second threshold, 35-mph will be displayed on one or more groups of VASS. Upstream of the first 35-mph VASS displays, 45-mph will be displayed as a transition from posted speed to an advisory speed (**See Figure 3-2**).

Within each variable speed zone, advisory speeds are posted from downstream to upstream such that, as congestion builds, the 35-mph advisory is displayed on more VASS, moving upstream concurrently ahead of the point of congestion. The first advisory viewed by traffic is always the 45-mph to provide a transition into 35-mph. Variable advisory speed zones and VASS placement were selected based on the VISSIM traffic modeling, which identified locations where VASS implementation has the greatest benefit to mobility.

Posting advisory speeds is a dynamic process using algorithms within a pre-developed module of ActiveITS. This module seamlessly integrates into ActiveITS.

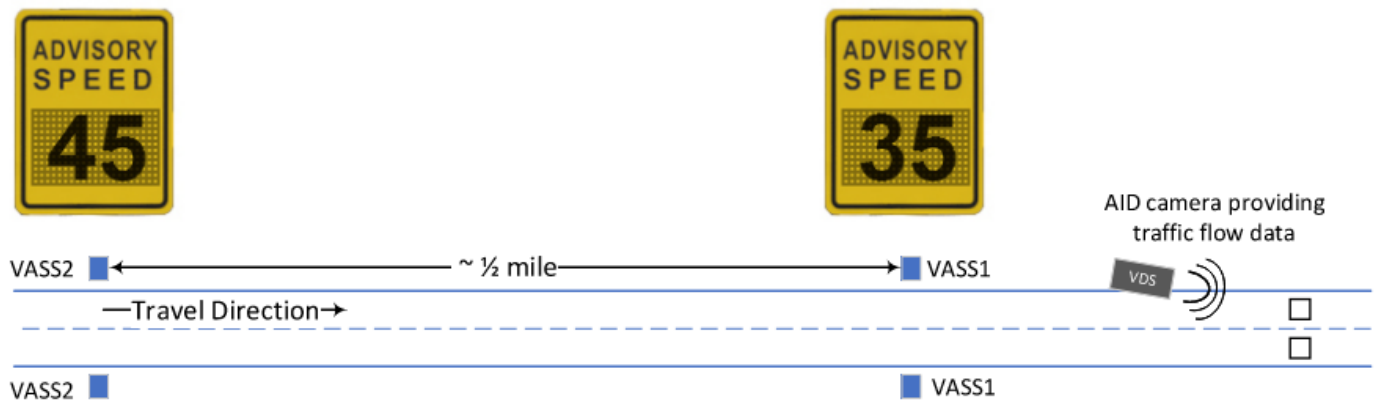

Figure 3-2: Typical VASS Layout

Purchase, integration, and testing of the module will be provided at no cost to MDOT SHA and is included in our proposal. Although the thresholds and algorithms for posting advisories will be developed during final design, coordinated with MDOT SHA and Southwest Research Institute (SwRI), conceptually, the process the module uses to determine if an advisory speed is appropriate and what speed is displayed is shown as a *Decision Tree* (**See Figure 3-3**). The decision is based on two speed thresholds compared to collected field data from the AID cameras. Those thresholds trigger a 45-mph or a 35-mph display. The thresholds are anticipated to be 50-mph and 40-mph, however, that is determined during final design with MDOT SHA and can be modified at any time after implementation by revising the thresholds in the software.

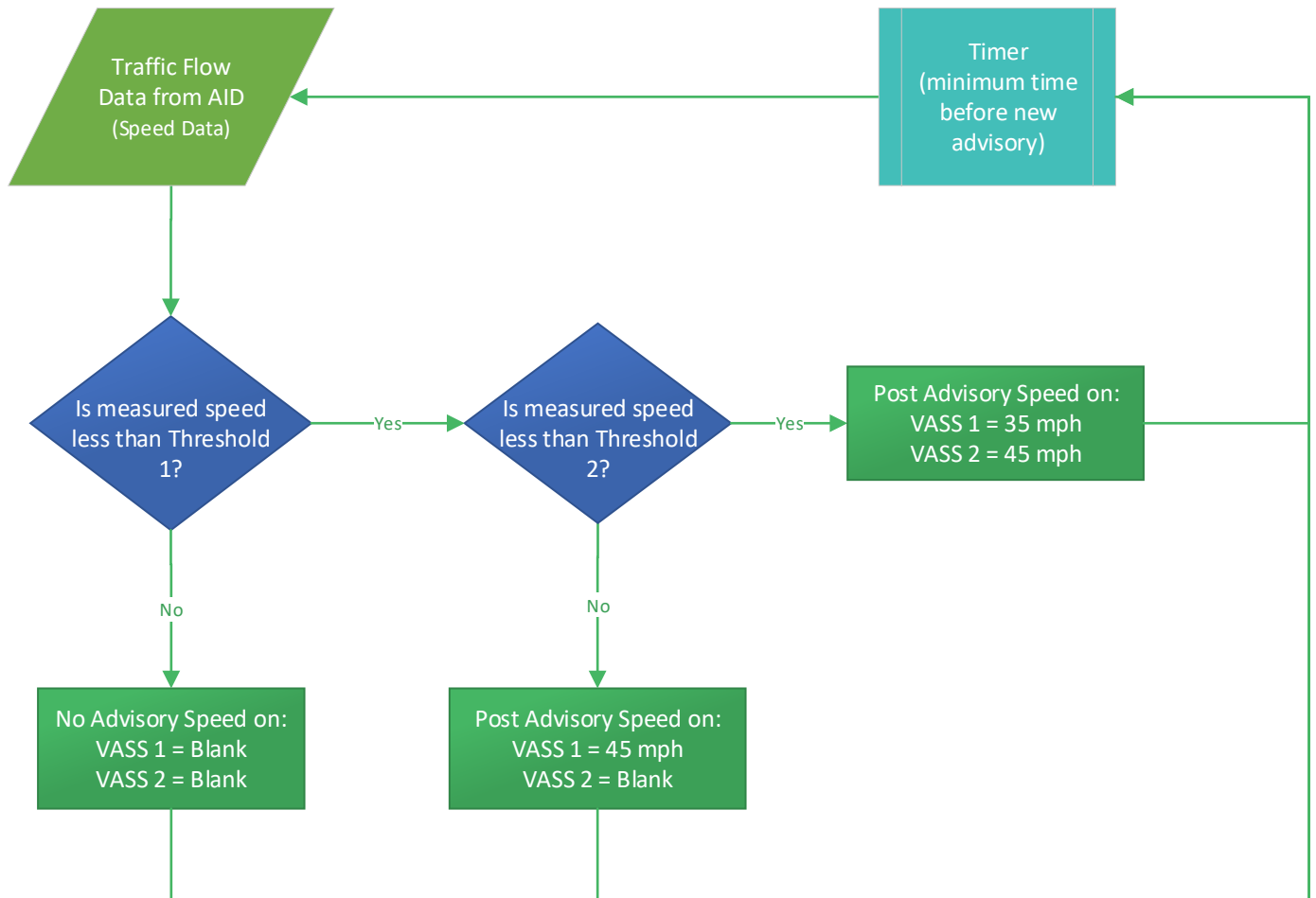

Figure 3-3: Speed Advisory Display Decision Tree

Once a threshold has been met and the system determines an advisory speed will be posted, an alert is sent to the Statewide Operations Center (SOC). This alert allows the operator to override the VASS system or, when warranted, permits messages to be displayed by CHART on existing DMS signs prior to the VASS to alert motorists of upcoming congestion.

In addition, on-ramps within a Variable Speed Zone will include a VASS along the ramp and mimic the display of the prevailing mainline VASS. The purpose here is to advise entering traffic of congestion ahead and to reduce speed and approach with caution. Much like the Speed Advisory Zones, motorists will reduce speed more gradually and more consistently with each other, which minimizes the frequency/extent of congestion and potential for rear end collisions that typically occur with more severe deceleration over shorter distances.

2. **Mitigation of PTS Use Lane HSSD:** Implementing the PTS Use Lane has traffic traveling closer to the median barrier. As a result, HSSD around left-hand curves will be reduced below AASHTO requirements at select locations, unless it is mitigated.



How it works: Our design minimizes reduced HSSD impacts for safe operations in a functional PTS Use travel lane for motorists. Specifically, we included primary mitigation of substandard HSSD by shifting the general-purpose lanes to the outside and moving the PTS Use Lane away from the median barrier, for eight curves

within the PTS Use Lane implementation limits. This allows the PTS Use Lane in these areas to be constructed with AASHTO-compliant 55-mph HSSD requirements.

3. **Improvements to Monitoring Conditions Impacting Throughput and Travel Times:** Additional monitoring capabilities using AID and enhanced CCTV coverage in our design enhances traffic flow management. It allows information to be disseminated more quickly and accurately to motorists through all of the different technologies MDOT SHA has available. This provides motorists with advanced warning of congestion and/or incidents, providing information for motorists to better plan their routes accordingly. Our design maintains the current vehicle detection system but enhances detection quicker for more accurate and comprehensive data, to promote quicker and improved traffic management responses, resulting in more throughput and lower travel time.

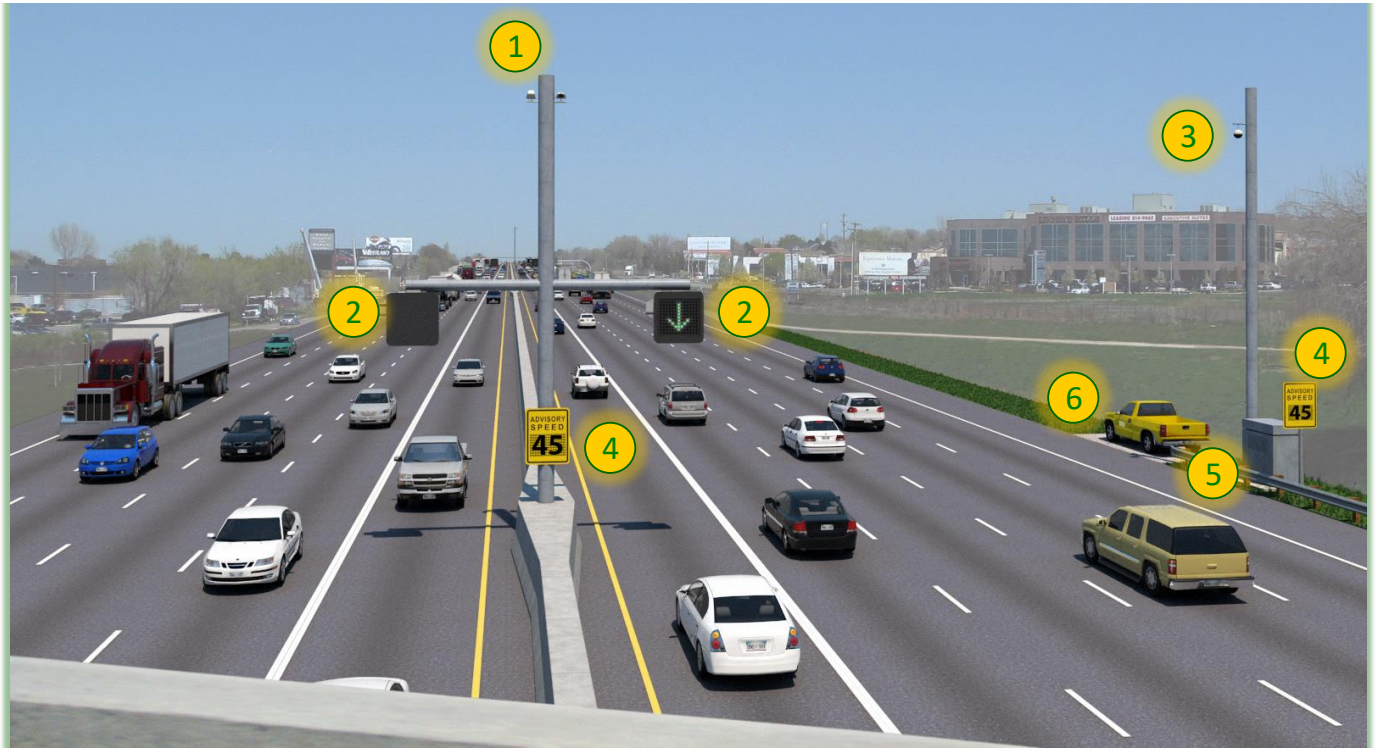

- ① - Automated Incident Detection Camera (AID)
- ② - Lane Use Control Signal (LUCS)
- ③ - CCTV Camera
- ④ - Variable Advisory Speed Sign (VASS)
- ⑤ - ITS Cabinet
- ⑥ - ITS Cabinet maintenance pull-off

Figure 3-4: Typical ITS Implementation Layout



How it Works: AID Devices collect critical data and transmit it back through ActiveITS to the SOC, including traffic data, such as travel speeds, throughput, and occupancy of each existing lane. AID also collects critical event data, such as stopped vehicles, fallen objects, pedestrians, and wrong way vehicles. Because of the critical nature and the role accurate data has in making traffic management decisions, our design uses 147 top-of-the-line FLIR

ThermiBot 2 cameras for all AID functions. The AID covers 100% of the PTS Use Lane, 65% to 75% of the general-purpose lanes and ramps. They are designed to provide unobstructed views of the PTS Use Lane with no chance of occlusions due to tall vehicles. Our layout/camera combination is designed to provide the most accurate, reliable data collection and incident detection.

Why Selected? The Corman Kokosing Team chose FLIR cameras for their proven quality, such as low Mean Time to Detect (MTTD) and low False Alarm Frequency (FAF). For example, real world applications revealed FLIR thermal cameras could detect pedestrians, stopped vehicles, and wrong way motorists with an accuracy of 100%, 94.3%, and 100% respectively; results you can rely on. The FLIR camera's thermal imaging means that detection is not interrupted by weather/environmental conditions or ambient light – operators can count on getting reliable data in all weather and time- of-day situations.

The FLIR cameras also send traffic event alerts when it detects changes in operational performance and incidents blocking shoulders and/or lanes. Our AID implementation gives operators a *traffic condition image* far beyond what the most other system are capable of, allowing technology to be their eyes and ears. This generates better, faster decision making to quickly apply MDOT SHA procedures to manage events. Additional details on these detectors is provided within **PTC's #1R2 and 2R2**.

When changes in performance or incidents are detected, messages are sent to the VASSs and to the SOC. With operator confirmation and when warranted, messages can be posted on existing DMS within CHART to notify motorists of conditions ahead, promoting safe/efficient traffic flow.

4. **CCTV Cameras:** New CCTV cameras will be installed to supplement the existing CCTV layout and provide advanced visual coverage of the corridor, which increases MDOT SHA's awareness and improves probability that incidents or operational breakdowns are identified quickly. Operators can more easily assess/address the situation as policy and procedures dictate. Whether during recurring or non-recurring congestion, CCTV can assist the decision maker to alter electronic signs and signals along the corridor to maximize lane use, which optimizes throughput and minimizes travel times when speeds reduce. Our proposed CCTV cameras are mounted to camera poles, with lowering devices, supplementing existing camera coverage providing full CCTV coverage of the PTS Use Lane section and general-purpose lanes as required in the RFP. These are separate from any detector cameras and possess Pan-Tilt-Zoom (PTZ) functionality, with nearly a 360° viewing range. **However, to ensure multiple views are available when needed, our proposal adds an additional CCTV cameras, with Pan-Tilt-Zoom functionality, within the PTS Use Lane section for an ultimate average spacing of 0.51 miles (double FHWA recommended density of one per mile and 60% higher than the 0.85 mile spacing required in the RFP).**
5. **Enhanced DMS Utilization:** Existing DMSs will be used similar to their current operation, but with connectivity to additional detectors, sensors, and cameras, messages will be more consistently clear and quickly updated as conditions change. They can supplement operation of the AID and VASS devices and can expand the number and type of messages that can be displayed to maximize advanced decision making for motorists. DMSs will provide travel time information, suggest alternate routes, and recommend they reduce speed ahead - all based on MDOT SHA's policies and procedures, which will improve throughput and travel time, especially under congested conditions.
6. **Minimizing Impacts to Existing Conditions:** Our design focuses on construction of the PTS Use Lanes to improve system capacity during peak hours without widening the existing roadway to accommodate an additional full-time travel lane. We also took precautions to not create other impacts as a result of implementing the PTS Use Lane, such as pinch points around bridges, narrow travel lanes, and non-AASHTO compliant outside shoulders that can affect overall IS-695 mobility or safety. By concentrating on these issues, we prevent impacts that slow travel time and reduce throughput. We struck a balance between these competing factors to provide a holistic system that works for motorists, environmental constraints *AND* the project budget.

Maintaining Functional Lane Widths: In most cases, the inside shoulder cannot just be restriped and signed to become a PTS Use Lane. Drainage, condition/height of median barrier, width and slope of shoulder, and sight distance are all competing factors in designing the PTS Use Lanes. A slight narrowing of adjacent general-purpose lanes via restriping/realignment can provide valuable space to accommodate the competing factors created by the PTS Use Lane. However, this may have an impact on traffic flow in the existing general-purpose lanes. The Corman Kokosing Team found creative, innovative solutions to address these factors without resorting to a large reduction in lane widths.



How it Works: Our proposed plan maintains at least 11.5-ft. lanes for the entire corridor. This may seem insignificant; however, maintaining this minimum width makes the reduction nearly unperceivable to the motorist. In fact, from an analysis of the survey data provided by MDOT SHA, there are two locations within the project limits where existing lanes are already between 11-ft. and 11.5-ft. ***Our design improves these two existing substandard locations by making all lanes 11.5-ft minimum.***

The Highway Capacity Manual (HCM) shows expected reductions in Free Flow Speed (FFS) due to reduced lane and shoulder widths. HCM, Exhibit 11-8 shows one can expect a reduction of 1.9 mph using 11-ft. lanes (while the PTS Use Lane is the only 11-ft. lane, conservatively, it would be applied to all lanes through the HCM analysis). Thus, there is little to no impact to travel speeds and throughput, preserving mobility within these 11.5 ft min width lanes, lanes while maximizing the length of the PTS Use Lanes.

Maintaining Functional Outside Shoulder Width: Shoulders are an important roadway feature as they provide a driver recovery area and safe place for disabled vehicles, minimizing negative traffic flow impacts. As stated above, there are many competing factors when designing the PTS Use Lanes. The Corman Kokosing Team generated a creative and innovative design that balances these factors without sacrificing functionality of the right shoulder, providing an AASHTO-compliant minimum 10-ft. shoulder (or minimum 6-ft. shoulder adjacent to some auxiliary lanes). This is vital while the PTS Use Lane is open and the median shoulder area is unavailable for emergency responders. As with the lane widths, this may seem insignificant, however, maintaining this minimum width preserves the function of these important features for the motorist, providing a refuge for disabled vehicles while preserving mobility within the corridor. These AASHTO-compliant shoulders are also available for emergency vehicles responding to an incident. Thus, there is no impact to travel speeds and throughput in the travel lanes, maximizing the benefit of the PTS Use Lane.

Minimizing Noise Caused by Increased Travel Speed: We considered the impact of more mobility and the potential impacts to noise generation for neighboring properties. We used the RFP's noise model provided by MDOT SHA and evaluated it for our design, allowing us to select improvements that are compatible with the MDOT SHA Noise Policy, including noise abatement as needed.

From our preliminary analysis, we anticipate two locations that may need additional noise attenuation in the form of extensions/modifications to existing noise barriers. A Type I Noise Analysis will be conducted during final design with attenuation provided per the MDOT SHA Noise Policy.

Minimizing Impacts to Adjacent Roadways: The Corman Kokosing Team considered the impact of our design on delay to local adjacent roadway network users. We used the RFP's VISSIM traffic model provided by MDOT SHA to evaluate our design and select improvements that do not impact adjacent roadways. Our improvements do not adversely impact local roadways or arterials. Improvements to mainline IS-695 mobility will actually improve the traffic flow on ramps, minimizing the potential for related ramp back up and congestion on adjacent roadways and arterials.

Minimizing Stormwater Management: Our proposed improvements to stormwater management systems support our design which have been carefully evaluated to confirm compatibility with our goal of improving mobility, with all BMPs located within existing right of way. We will primarily use bioretention facilities located throughout the project area to address Maryland Dept. of the Environment (MDE) stormwater quality requirements (MDE Technical Memo #4) regarding

the conversion of median shoulders to travel lanes. The minor additional pavement we are also proposing will also be addressed per MDE requirements.

Minimizing Impacts to Cultural, Historical, and/or Archeological Sites: Our proposed improvements have been evaluated for compatibility with our goal of improving mobility and do not impact cultural, historical, or archeological sites. There will be a formal Assessment of Effects analysis for cultural resources during final design, in accordance with the Programmatic Agreement executed by MDOT SHA. Currently, we are proposing four locations of roadway widening (outside existing shoulder areas) and none are adjacent to the 11 National Historic Preservation Act (NHP) listed or eligible architectural properties, as identified in the Categorical Exclusion.

7. Improvements to Harford Road Acceleration Lane: Our design improves the Harford Road interchange as presented in **Figure 3-5**. MDOT SHA has previously removed the Inner Loop exit loop ramp to Harford Road, eliminating a weave area with the Inner Loop eastbound on-ramp. Modern design requirements are more stringent than they were when this interchange was constructed, which left the acceleration lane at the end of the eastbound on-ramp shorter than desired by current standards.

We included in our proposal extending this acceleration lane to meet current standards, but more importantly, to reduce traffic friction between the ramp traffic and adjacent general-purpose lanes by improving the ability of entering traffic to merge into IS-695 traffic flow easier/safer, and as a result, with less impact to prevailing mainline speeds. This improvement benefits traffic flow and mobility of the mainline, as well as Harford Road motorists.

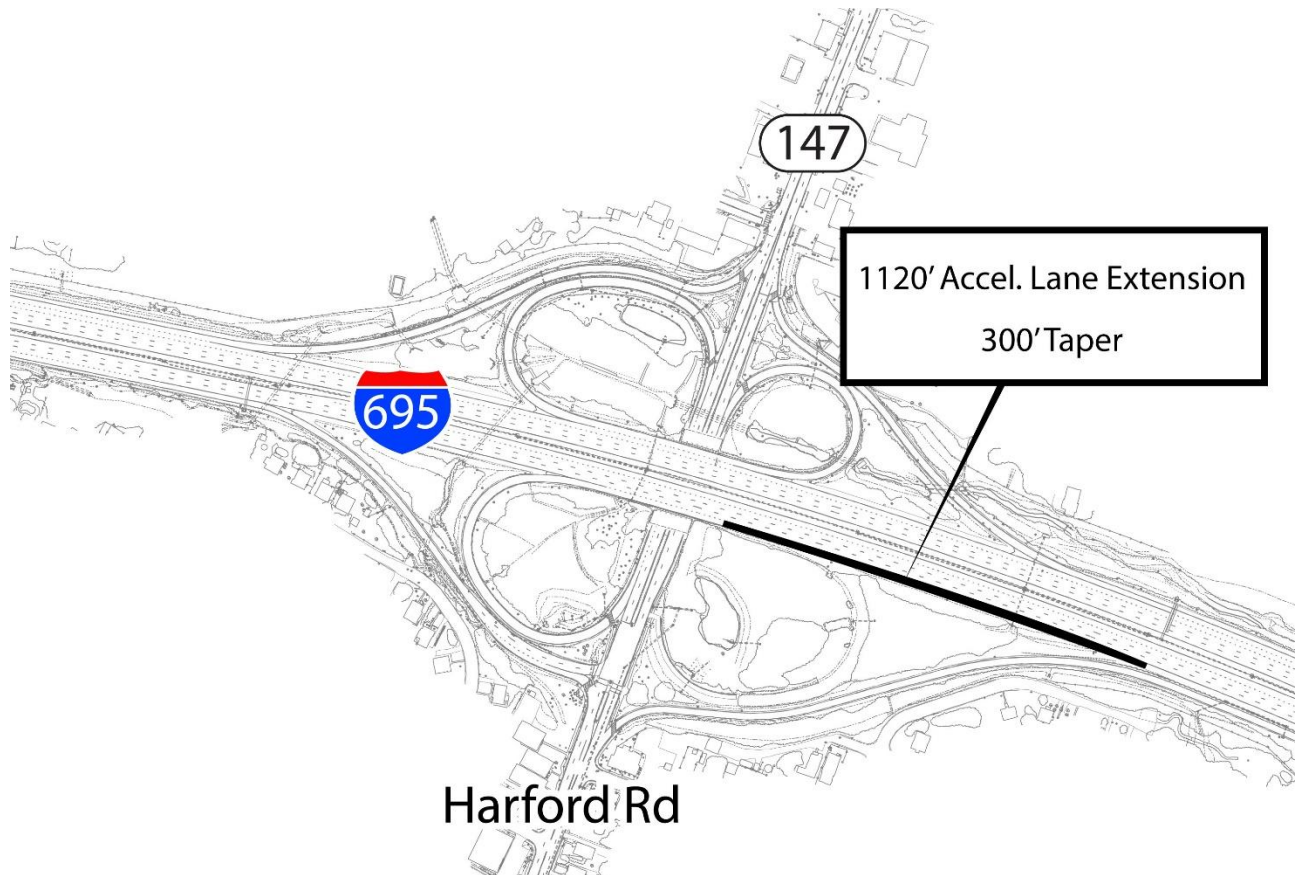

Figure 3-5: Acceleration lane extension



ii. Discuss how our Total Project, including static-dynamic median part-time shoulder and other improvements, reduces recurring congestion in terms of travel time, vehicle throughput, density, intersection operations, queues and vehicle network performance, along the IS-695 Outer loop and Inner loop and on the connecting ramps and arterial roadways.

The Corman Kokosing Team's design provides complimentary tools to manage mobility and reduce recurring congestion along IS-695. Adding capacity is a surefire way to reduce recurring congestion through the corridor and the most efficient way to add capacity is to use managed lanes to focus on where additional capacity is actually needed.

In this case, it is a PTS Use Lane.

PTS Use Lanes provide capacity when justified based on temporal demand. We focused on a design that maximizes the length of the PTS Use Lane implementation limits and includes *state of the art* technology to manage the PTS Use and general-purpose lanes to reduce recurring congestion.

Proposed Improvements:

- ✓ Added 30 total miles of new PTS Use Lane
- ✓ Reduced travel times by 55%
- ✓ Increased throughput 42%
- ✓ Reduced density 38%
- ✓ Improved overall network performance by reduced total delay by 31%

Length of PTS Use Lane: Proposed locations of the PTS Use Lanes for the Inner and Outer Loops were selected based on maximizing PTS Use Lane implementation limits to improve mobility in the most cost-effective way. Part of the selection was based on motorist experience. Our design selected the location and length based on overall length in miles and lane continuity, as these had the greatest affect to mobility. Short PTS length or discontinuity in the PTS Use Lane greatly reduces the motorist experience, creates bottle necks between fragmented sections, and introduces multiple diverges/merges increasing the potential for congestion and crashes. These are important factors that are weighed against operational factors. Our design constructs PTS Use Lane through **80.5%** of the corridor:

- ✓ Inner Loop: From IS-70 to Cromwell Bridge Road (15 miles)
- ✓ Outer Loop: From Cromwell Bridge Road to IS-70 (15 miles) **(See Figure 3-6)**

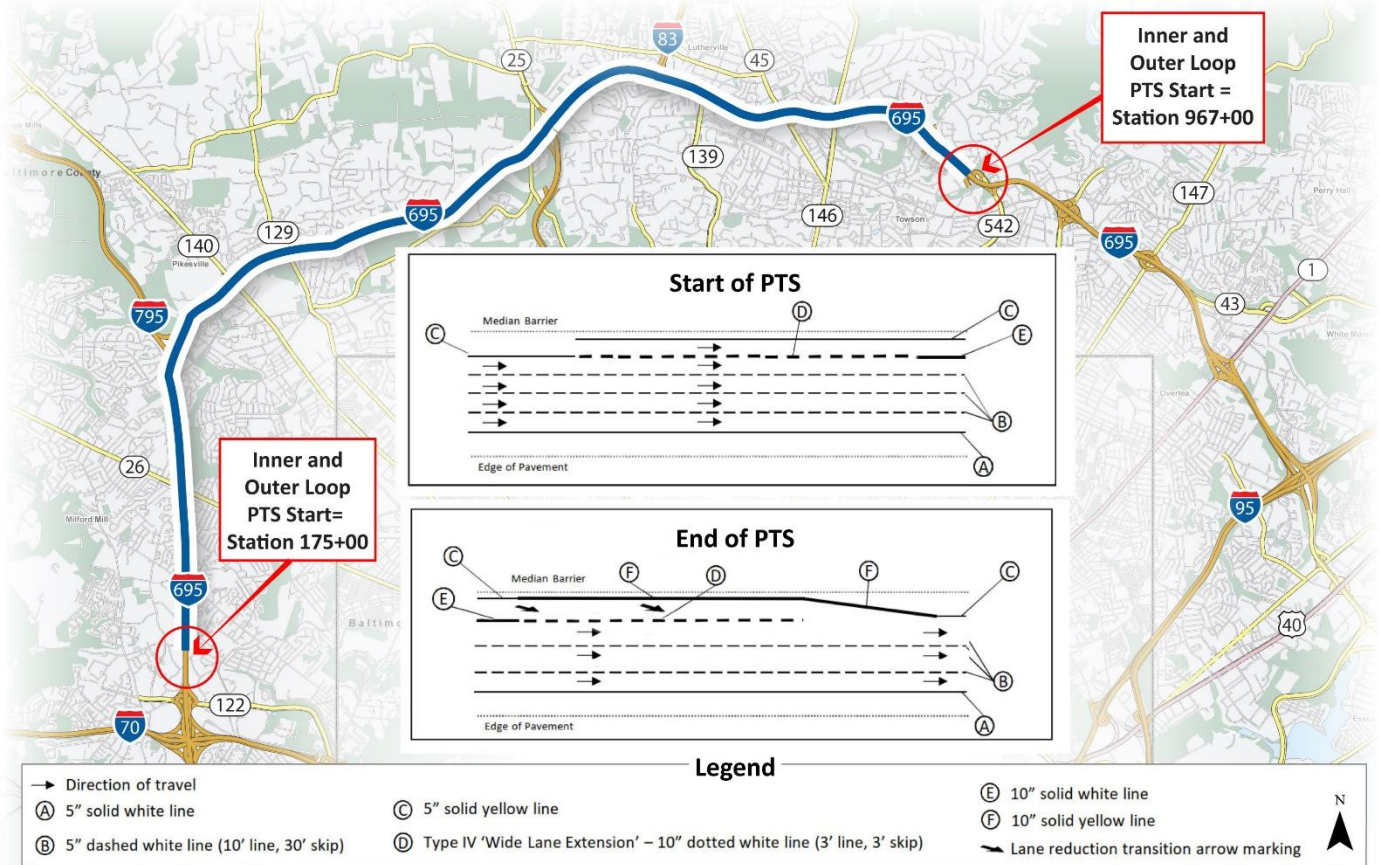

Figure 3-6: Limits of PTS Use Lanes

Process for Selecting Limits for PTS Use Lanes: The Corman Kokosing Team selected locations for PTS Use Lane implementation through a detailed/iterative traffic analysis using the VISSIM model provided by MDOT SHA to maximize mobility cost effectively while incorporating benefits to safety, recurring congestion, and incident management in locations where mobility benefits may not be as substantial. We evaluated project segments to determine the implementation strategy that maximizes vehicle throughput, minimizes vehicle travel times, and creates a more reliable commuter trip along IS-695 within the project limits in the most cost-effective way.



How we got there: Starting with mobility, our traffic analysis evaluated options/combinations of options to determine the best locations for PTS Use Lane implementation from a mobility perspective. We also developed preliminary cost estimates for individual project segments that were evaluated concurrently with the VISSIM model results. Each was evaluated to determine which Inner and Outer Loop option(s) will provide the best value to MDOT SHA and motorists, by improving mobility and maximizing the PTS Use Lane implementation limits within the available budget constraints.

Other considerations included devising the most effective implementation strategy. Between the Outer and Inner Loops, the Outer Loop experiences higher congestion levels. Implementing PTS Use Lane on the Outer Loop vs. the Inner Loop provided greater mobility benefits. We then prioritized Outer Loop locations to gain the greatest mobility benefit within the corridor within the allowable budget.



While analyzing the cost of ITS improvements shown to increase mobility in the VISSIM model, we noticed improvements in one direction (Inner Loop or Outer Loop) were substantially higher than in both directions. The Corman Kokosing Team then researched locations where the maximum mobility improvement occurred in both directions. Additionally, cost-effective construction means & methods were considered to reduce replacing infrastructure not necessarily required to operate this system.

We conducted an extensive evaluation to determine the most effective locations to install PTS Use Lanes on the Inner and Outer Loops. Our goal was to balance the reduction in recurring congestion with the overall length and continuity of the PTS Use Lanes through the project. Recurring congestion during the evaluation is quantified by several Measures of Effectiveness (MOE), travel time, vehicle throughput, and density. The selected PTS locations results in the following during the AM/PM peak hours of their respective peak periods:

- ✓ **Travel Time:** The most important MOE is travel time of the corridor from IS-70 to MD 43. Travel time encompasses most other measures into it, such as average speed and density, and is a direct numerical representation of the motorist's experience. It includes potential speed reductions at interchanges and lane reductions. It incorporates lane imbalances and traffic volume differences in areas between major interchanges, such as the IS-83 weave segment. Most importantly, it can be easily explained to the general public and is a primary performance measure to assess MDOT SHA's success in managing facilities.

Our proposed travel time was determined through VISSIM modeling and all of our proposed improvements are specifically targeted to provide as much travel time saving as possible. We targeted the Outer Loop first, because the No-build travel time was much greater than the Inner Loop travel time, especially in the AM where the model indicates it will take 236 minutes to travel the entire corridor Outer Loop in 2040. The Inner Loop, while not as severe, is also expected to have unacceptably low travel times in 2040, especially in the PM where the travel time increases to 134 minutes. These patterns can be seen in **Figures 3-7, 3-8, 3-9, and 3-10 on pages 36 and 37**. The data does not point to a specific cause of congestion or one specific bottleneck along either direction that causes a major delay. Instead, the model indicates that the overall demand in 2040 exceeds capacity of the existing corridor causing congestion throughout. As travel demand approaches the capacity, traffic flow becomes unstable and congestion ensues. Once traffic flow becomes unstable, areas around interchanges, especially IS-795 and IS-83, curves and other friction causing geometrics have a significantly bigger impact to traffic flow.

Our design adds capacity along 80.5% of the IS-695 corridor, covering both IS-795 and IS-83 interchanges, to reduce and limit the instances this unstable traffic flow occurs. That is why in the worst hour, compared to No-build, our proposed design takes less than ½ the time to travel the Outer Loop in 2040 in the AM peak hour, or 91.4 minutes. In the worst hour on the Inner Loop, the PM peak hour, our design reduces the time to travel the corridor in 2040 by 1/3, or 90.5 minutes. While these are impressive results, we understand that in the future, demand will again approach capacity. As this occurs, traffic flow is at risk of again becoming less stable. That is why we have proposed additional measures in the VASS system, to help smooth traffic flow and reduce the risk that it becomes unstable. VASS improve travel time by promoting similar travel speeds in the areas the need it most. As a result, motorists have to brake less often and less severely, limiting differences in speeds and smoothing traffic flow. This is particularly valuable around the major interchanges at IS-795 and IS-83 and will have a greater impact as traffic from those facilities merge onto IS-695. In addition, our design includes VASS on ramps from these major interchanges, providing the same smoothing benefits for traffic entering IS-695.

The impressive benefits we achieve in travel time are mirrored in other MOEs discussed below. The travel time is lower because of our targeted design and for the same reasons, throughput is higher, and the density of traffic is lower, all positive impacts to mobility. As further evidence, the modeled total network delay, which considers all hours within the peak period and all directions, geometric features, traffic volumes, ramps, and arterials also shows an impressive improvement. In fact, the models indicate that that motorists will save a total of 18.6 Million hours in the four-hour AM

period and 23.6 Million hours in the four PM hours. Collectively, that is over 1/3 less delay over No-build 2040 traffic. (See Table 3-2).



BENEFIT: Our design reduces travel time when compared to No-build conditions by **34%** and **55%** in the Inner and Outer Loops, respectively (See Table 3-1). This means it takes approximately **half the time** to travel from one end of the corridor to the other during the time when most motorists want to travel.

Throughput: While Travel Time is the most important MOE to describe the motorist experience, throughput is a measure of the number of motorists who get to experience it. Throughput is measured in vehicles per hour and is a weighted average of data collection points at select locations throughout the model of the corridor from IS-70 to MD 43. Each of these data collection points represents a segment of modeled roadway and each segment is calculated as a throughput per length of that segment. The combination of each segment's weighted average results in the average throughput for the entire corridor, considering that some areas have higher throughput while some have lower.



BENEFITS: Our design reduces Travel Time in the future when compared to No-build conditions. Further, while motorists take less time to travel through the corridor, **42%** more motorists can take advantage of that savings (See Table 3-1). **This means more motorists can travel the corridor and do it in less time.**

Density: Provides an indication of how closely-spaced vehicles are within the corridor. Closely-spaced vehicles tend to affect other motorists, causing frequent braking and increasing congestion. Vehicles spaced further apart have less interaction, leading to smoother traffic flow and reduced congestion. Density is measured in passenger cars per lane per mile and is a weighted average of data collection points at select locations throughout the model of the corridor from IS-70 to MD 43. Each of these data collection points represents a segment of modeled roadway and each segment is calculated as a density per length. The combination of each segment's weighted average results in an average density for the entire corridor, considering that some areas have higher density while some have lower.



BENEFITS: Our design significantly increases the throughput when compared to No-build conditions. What's more impressive is that while more cars are able to travel through the corridor, the density of vehicles is reduced by **38%**, which means **more vehicles are traveling the corridor with more space between them.** That increases mobility and reduces congestion as motorists need to break less often and less aggressively (See Table 3-1).

Network Performance: This gives an indication of how the total network performs, including ramps and arterial streets. It provides a high-level view of the total system without getting down to the details/nuances of each transportation network component. It can be measured in several ways; however, the most telling is total delay (a measure of the total delay, in hours, of all vehicles in the model) and latent demand (a measure of how many vehicles would like to enter the model, but cannot).



BENEFIT: Our design significantly decreases the total delay of the network when compared to No-build conditions. In fact, there is a 31% decrease, which means that when you add up all of the delay of all the vehicles in the model for each peak hour, there is nearly half the delay from our design than No-build. This is supported by measuring the latent demand. Because traffic flows better, more cars can enter the model during the running of each peak hour. Because of our design, latent demand is reduced by 33%, which means twice as many cars can enter and travel through the corridor during the AM and PM peak hours (See Table 3-2).



Measures of Effectiveness -Total PTS length, Travel Time, Throughput, and Density											
Inner Loop											
Measures of Effectiveness (MOE) for Peak Hour (8:00-9:00 AM and 4:00-5:00 PM)											
Scenario	Length of PTS (miles)	PTS % of Total Possible	Average Peak Hour Travel Time (min)		% Decrease in TT (from No-Build)	Average Peak Hour Throughput (pc/hr)		% increase in Avg Throughput	Average Peak Hour Density (pc/ln/mi)		% Decrease in Avg Density
			AM	PM		AM	PM		AM	PM	
Existing 2018			31.5	42.5		6,607	6,839		40.1	47.2	
No-Build 2040			74.3	133.5		5,938	5,267		80.0	104.6	
Proposed 2040	15	80.5%	45.9	91.4	34%	6,952	6,213	17%	57.4	78.8	26%
Outer Loop											
Existing 2018			57.5	36.6		6,529	6,799		65.5	43.9	
No-Build 2040			235.6	166.6		4,012	4,655		146.5	131.9	
Proposed 2040	15	80.5%	90.5	92.0	55%	6,414	5,927	42%	89.8	83.5	38%

Percent decrease or increase calculated from No-build to Proposed

Table 3-1: Measures of effectiveness Part 1 (Total PTS, Travel Time, Throughput, and Density)

Measures of Effectiveness - Total Delay and Latent Demand						
	Total Delay (Million veh-hours)		% Decrease Avg Delay	Latent Demand (veh)		% Decrease Avg Latent Demand
	AM	PM		AM	PM	
No-Build 2040	55.2	82.5		28,216	67,636	
Proposed 2040	36.6	58.9	31%	16,657	47,813	33%

Percent decrease or increase calculated from No-build to Proposed

Table 3-2: Measures of Effectiveness Part 2 (Total Delay and Latent Demand)

Peak Hour Spreading: While these results are impressive and indicate our design allows more motorists to move faster and safer, a deeper evaluation is needed to identify ALL the benefits.

Impressive results for the two most congested hours per day only tell part of the story. It is important to understand that managing recurring congestion means managing the peak hour and surrounding *shoulder* hours making up the peak period. A reliable measure of the strength of our design is a comparison of the modeled duration of that peak period vs. its potential maximum duration – or peak hour spreading.



To show the difference in peak hour spreading between our design, No-build and existing conditions, we used model results determined the average speed for each hour during each peak period. AM and PM peak periods exhibit the same behavior therefore, the graph below (**Figure 3-11**) shows the speed profile for the AM period only for the sake of simplicity. Here speed is used as an indicator of capacity during different hours. During existing conditions, represented by the grey lines, the peak period begins around 6:00 AM of the peak period, congestion starts to build up to 8:00 AM and speeds go down. At the height of the peak hour, the speed is the slowest, since that's when the most motorists are traveling the corridor creating congested conditions. Later in the peak period, traffic volumes begin to reduce, speeds begin to go up, traffic volumes decrease and traffic flows more freely, and speed recover by approximately 9:00 AM.

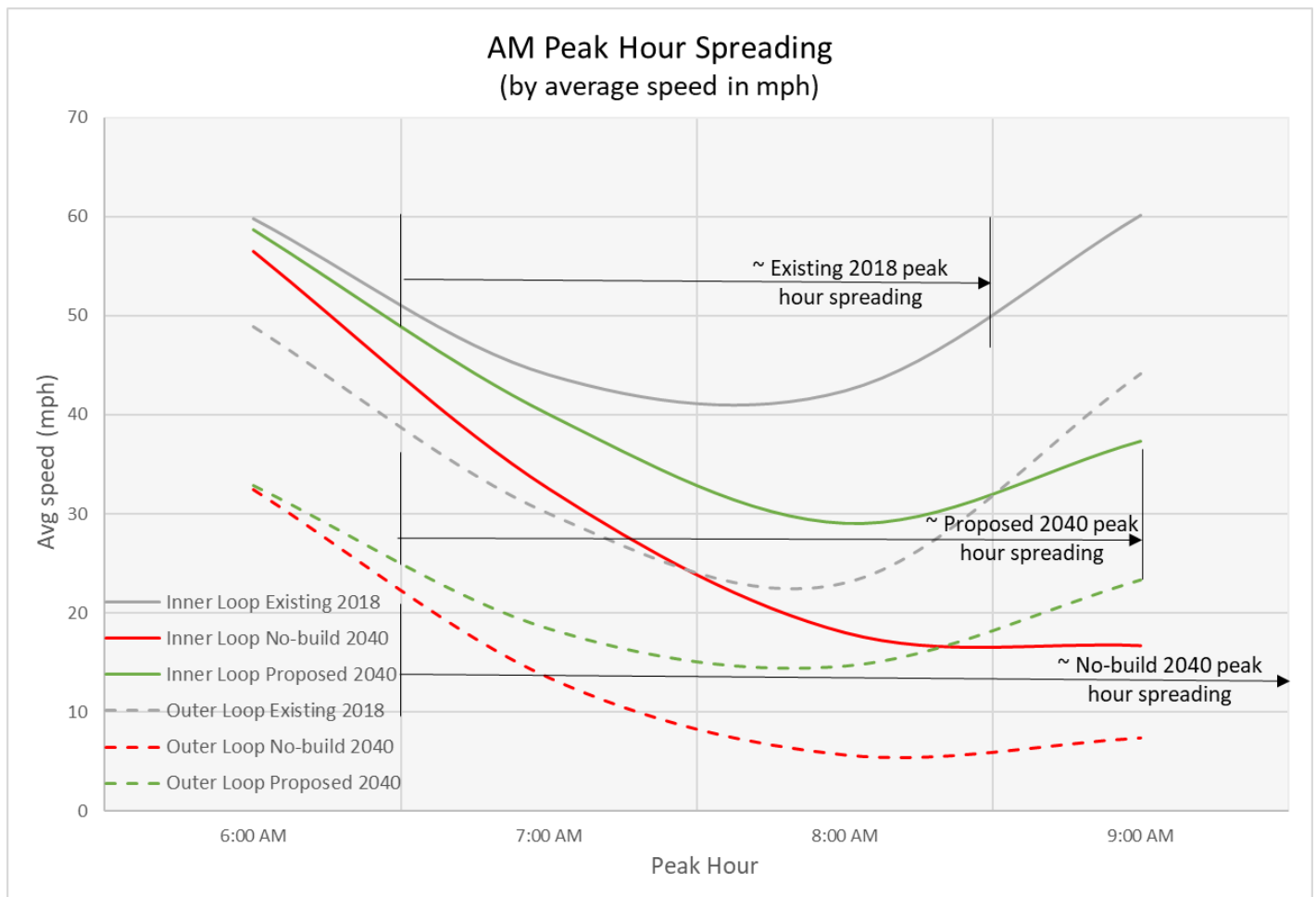

Figure 3-11: AM Peak Hour Spreading

Under No-build conditions, represented in the graph by the red lines, the corridor capacity is reached sooner in the day, forcing traffic to slow down and potentially stop. All motorists cannot make it through the corridor during that hour and, therefore, some are deferred until the next hour, adding to the volume of vehicles for that hour, resulting in a slower speed. It also results in less throughput, preventing additional motorists from traversing the corridor and again being deferred until the next hour. This continues until after the peak hour when volumes decrease enough to be under the corridor's capacity, allowing speeds to return. Because not all vehicles can travel the corridor during the hour they arrive, the peak hour spreads.

No-build conditions will have a peak hour spread, creating a peak period that is longer than four hours. This is represented in the graph because the red lines are nearly flat between 8:00 AM and 9:00 AM. For No-build conditions, recovery from peak hour spreading doesn't occur until after 9:00 AM.



Our design provides additional capacity, which means more motorists can travel the corridor during the hour they arrive, without being deferred to the next hour. This reduces peak hour spreading, greatly reducing congestion in the hours leading up to and after the peak hour. Our design’s peak period is less than three hours long, evident by the recovery in average speed near the 9:00 AM hour. Further, our designs recovery during the peak hour occurs similar to existing conditions. PM exhibits similar characteristics. **Figure 3-11 on page 34** shows the relationship between peak periods for the Inner and Outer Loops separately. Our design results in approximately a 30% reduction in the peak period from the no build condition.

Travel Time Reliability: The Corman Kokosing Team’s design achieves impressive improvements in all measurable categories of mobility. However, it is important for motorists to know how often these results will be achieved; once in a while is not enough.

Measuring the travel time reliability provides an indication of how much variation there is in the MOEs reported. MOEs represent an average of how well the system performs, but does little to indicate variation in that performance from day to day. That variation can be measured in terms of standard deviation in travel time. Variations occur with multiple runs of the model. Random seed numbers modify model parameters slightly to deliberately simulate this variation. As a result, some runs provide a better travel time than others, even though the design of the road is unchanged. Based on these travel times for each run, a standard deviation is calculated. The higher the standard deviation, the less reliable the corridor is likely to be in terms of travel time from one day to the next. For example, in the No-build 2040 for the Outer Loop, the standard deviation is 16.5 minutes in the AM peak hour. That means that there is approximately a 68% chance that a motorist’s travel time will be between 219.1 and 252.1 minutes of overall travel time, 16.5 minutes, plus or minus.

Our design for the same scenario has a standard deviation of 4.5 minutes, or approximately a 68% chance that a motorist’s travel time will be between 86.0 and 95.0 minutes of overall travel time; obviously, a significantly more reliable commute.

CONCLUSION

When comparing No-build vs. build conditions, our design not only provides a significant improvement in mobility, evident by the 55% faster travel time, but it is also more reliable for motorists, evident by the **reduction of up to 12 minutes of standard deviation**. This is a design that provides significantly more mobility and reliability.

Travel Time Reliability				
Inner Loop				
	Total Travel Time (min)		One Standard Deviation for Peak Hour (min)	
	AM	PM	AM	PM
Existing 2018	31.5	42.5	1.4	1.6
No-build 2040	74.3	133.5	10.0	11.1
Proposed 2040	45.9	91.4	4.2	6.4
Outer Loop				
Existing 2018	57.5	36.6	3.3	3.1
No-build 2040	235.6	166.6	16.5	11.2
Proposed 2040	90.5	92.0	4.5	5.1

Table 3-3: Travel Time Reliability

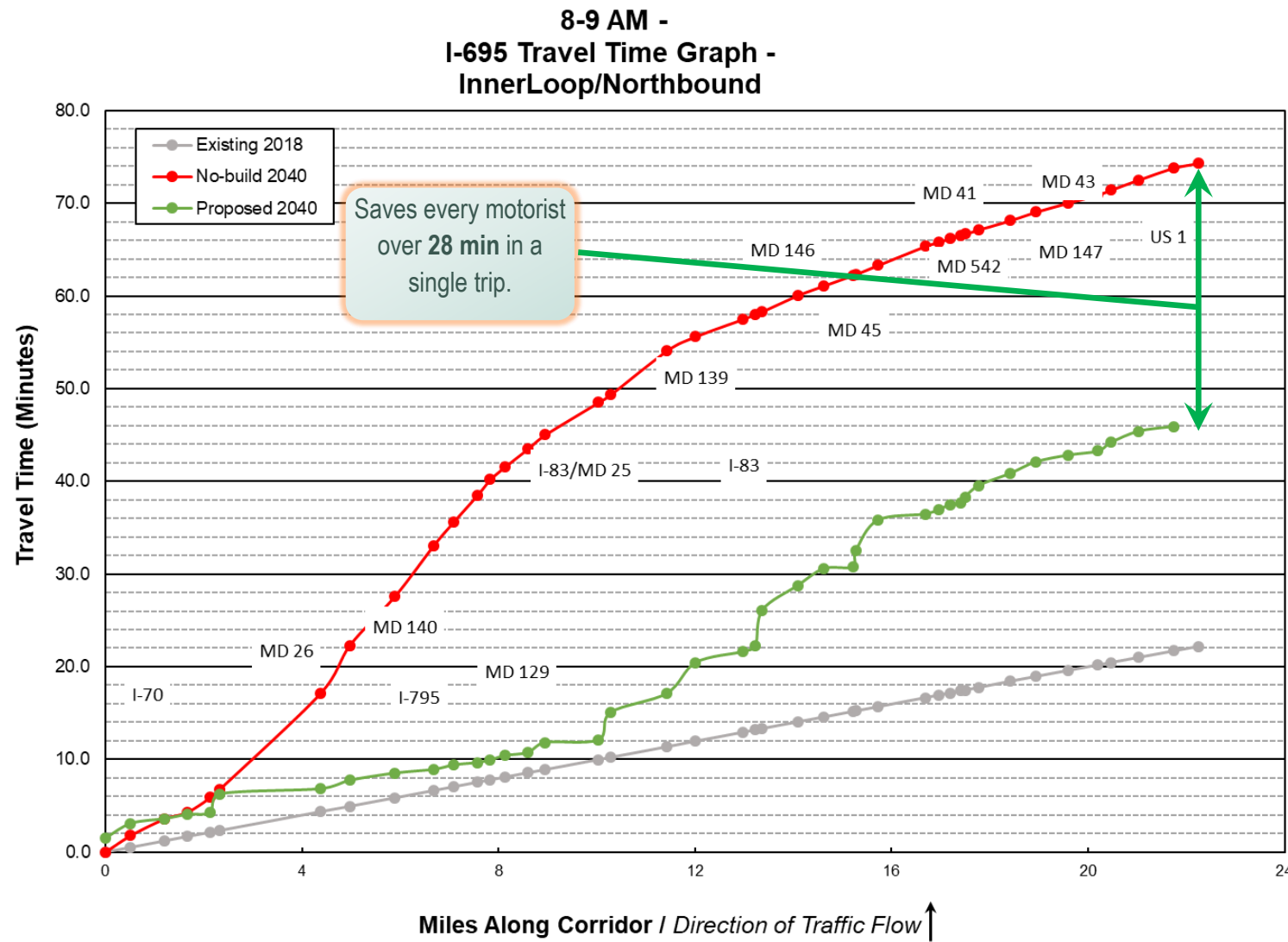

Figure 3-7: Inner Loop AM Travel Time

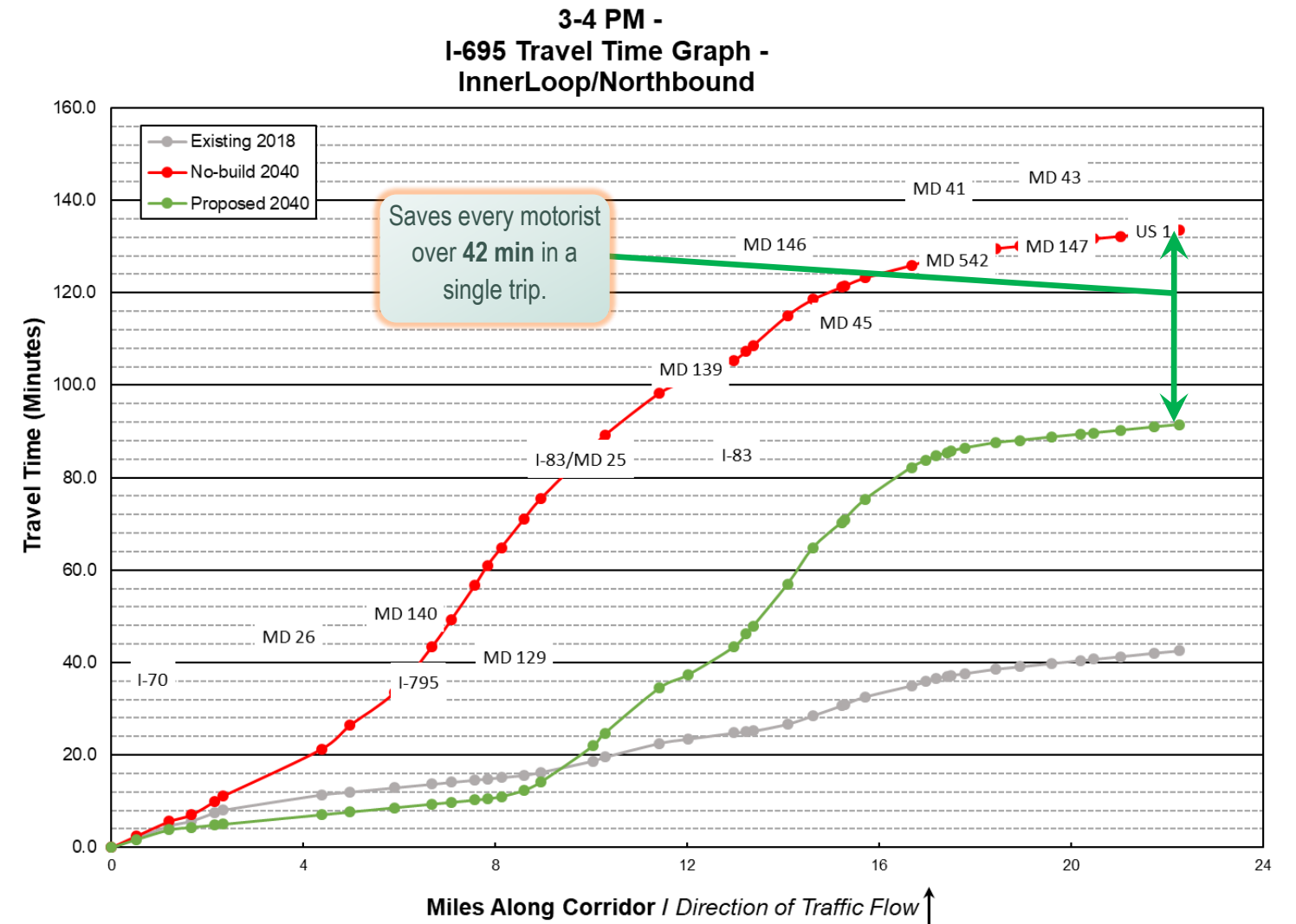

Figure 3-8: Inner Loop PM Travel Time



8-9 AM
- I-695 Travel Time Graph
- OuterLoop/Southbound

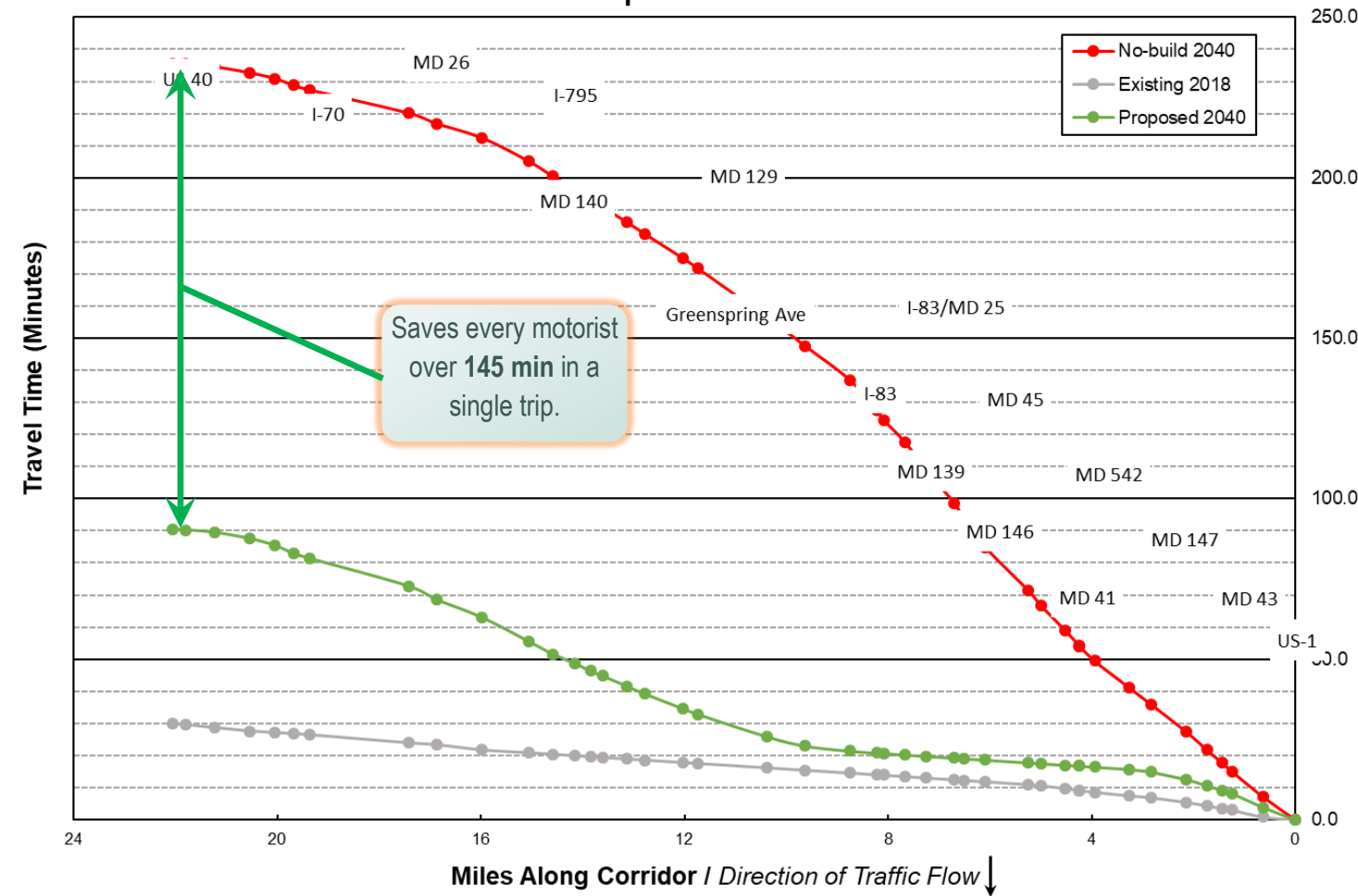

Figure 3-9: Outer Loop AM Travel Time

4-5 PM
- I-695 Travel Time Graph
- OuterLoop/Southbound

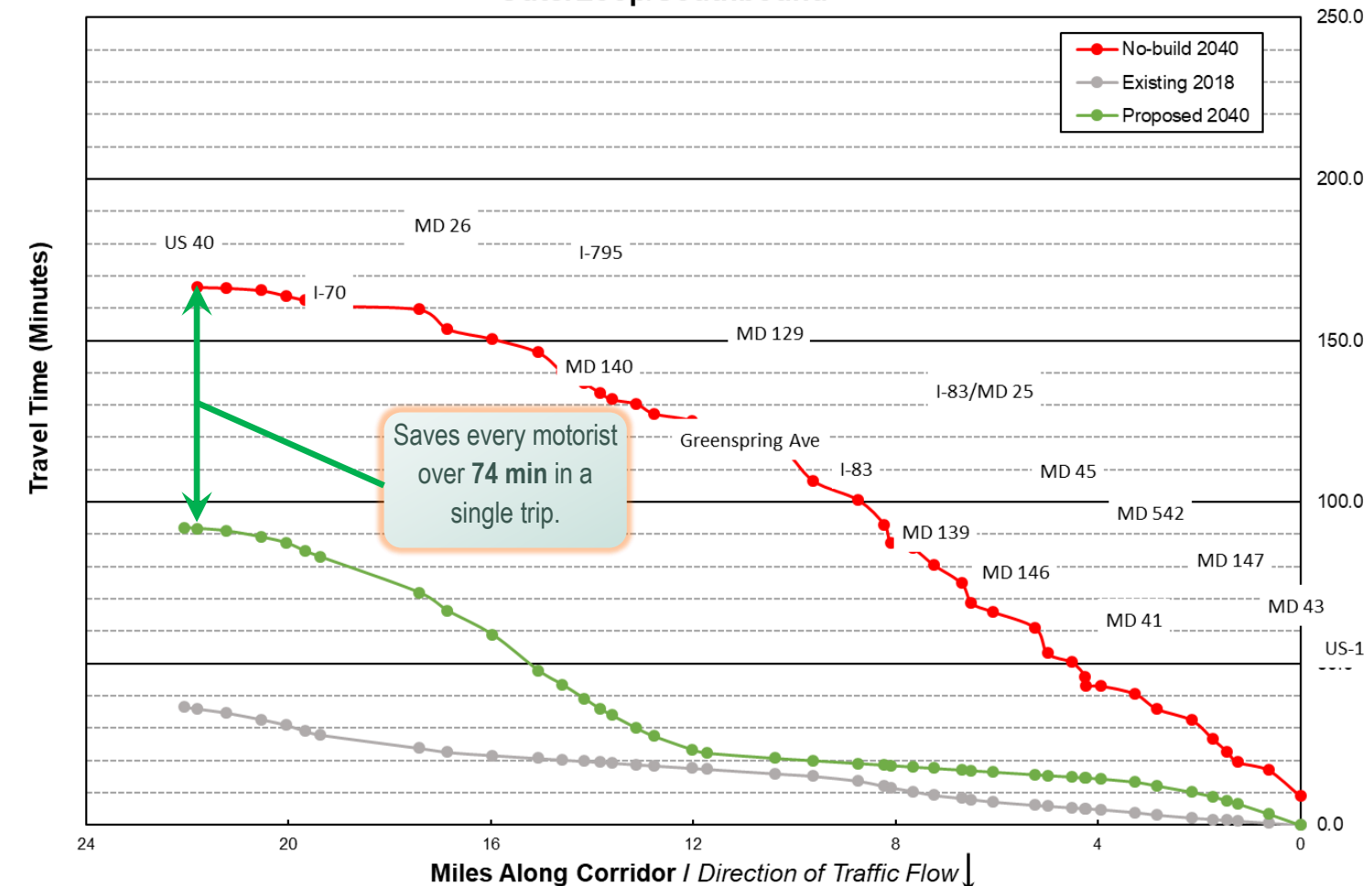

Figure 3-10: Outer Loop PM Travel Time

Connecting Ramps: Operation of connecting ramps is interconnected to the operation of IS-695. When improvements are made on the mainline, corresponding improvements are realized on the connecting ramps. Improvements to ramp operations can be measured in a number of ways, however, the best indicator of ramp operations is throughput of our design vs. No-build. Based on the model, most ramps along IS-695 have little to no change in throughput. This is primarily due to the ramp volume of the No-build condition being below capacity. Our design therefore also accommodates that volume of traffic.



BENEFIT: Our design significantly improves density and LOS of the merge, diverge, and weave areas of associated ramps, especially within the area with PTS Use Lane. Many ramp areas also have an increase in volume, which means that even in areas where density or LOS does not improve, more motorists can use the facility, providing more mobility to more motorists.

Intersection Operations and Arterial Roadways: Except for VASS on specific ramps our proposed design does not include any other improvements that directly impact intersections or arterials. However, by implementing our design, the ramps and mainline improve, reducing the chance that congestion on IS-695 hinders motorists as they travel through the intersections and along arterials.

How our PTS Use Lanes Reduce Recurring Congestion: By providing added capacity when it is needed – maximizing the facility’s value and reducing density. Added capacity improves vehicle throughput and minimizes travel time when volumes increase during peak periods. Because of the capacity the PTS Use Lane provides, the peak period is shorter and volumes in the times around the peak hour are less. By association, speeds are maintained closer to conditions outside of the peak period, so the resultant change in speeds are lower, thus reducing the intensity of peak-period congestion. As speeds are more optimally maintained, queues will less likely occur, but, if they do, they will be shorter in length and dissipate more quickly.



How it Works: Initially, the PTS Use Lane will operate on a fixed schedule, covering the peak hours per current traffic volume trends. However, as traffic volumes grow into the future, the ITS we designed for the PTS Use Lanes allows operation of the lanes to change from static to dynamic. A continuous stream of data from every AID camera allows MDOT SHA to monitor the historical operations of the lanes to determine when dynamic operation is appropriate. While the ITS is scalable, new equipment is not required to transition to dynamic operation. Opening/closing the PTS Use Lane allows the system to self-determine appropriate hours of operation. Because it operates dynamically based on actual traffic data, the system adapts to variations in traffic volumes, speeds, and densities. As a result, it can automatically provide extra capacity when needed and add the security of a wide shoulder when not, helping to manage recurring/non-recurring congestion. Further, when the PTS Use Lane is dynamic, parts of it can be opened if a particular location faces congestion, perhaps from an incident, while the remainder of the PTS Use Lane remains closed, maximizing the value of an available shoulder for incident response.

We concentrated on a PTS Use Lane design that is easy to manage today, such as time-of-day operations, with elements in place to transform into a more complex dynamic operation that allows the ATM more control over when and how the lanes operate. This is significant as the need to provide added mobility by the PTS Use Lane today is different than what will be needed in the future, requiring a system adaptable to continuously changing conditions. This is demonstrated by comparing existing conditions and future No-Build conditions to the designed future Build condition featuring the PTS Use Lane.

How Variable Advisory Speed Signs (VASS) Reduce Recurring Congestion: In our design, the VASS serves dual roles. They supplement operation of both the PTS Use Lane and general-purpose lanes. It is the same for both roles; once the system detects speeds are reduced to a certain threshold, the system automatically adjusts the VASSs to advise motorists of congestion ahead and a lower travel speed is appropriate (known as speed harmonization).

As speeds start to reduce in peak travel periods, speed harmonization is implemented by activating the VASS, which gradually slows motorists over a longer distance ahead of the congested area and maintains more consistent speeds within congested locations. This lowers the risk of more severe congestion and promotes a faster recovery to free flow conditions. As congestion starts to recede, the VASS can be adjusted similarly to achieve maximum traffic flow and the highest mobility.

How PTS Use Lane and VASS Improves Ramps and Arterial Roadways: Service quality improvements along IS-695 will translate to improvements on interchange ramps and crossing arterial roadways. With improved efficiency and reliability along IS-695, queuing along off-ramps have a lower probability of operational breakdown as well as a decreased crash risk along the mainline. More efficient and reliable mainline traffic flow allows smoother merges from on-ramps, reducing the likelihood of queuing along the ramp and adverse impacts at ramp termini.

CONCLUSION

The Corman Kokosing Team's design uses multiple strategies to improve mobility. We have 30 miles of new PTS Use Lane, targeting areas that provide the most benefit. We also have a host of other strategies: Variable Speed Zones that help smooth traffic flow during congested conditions; enhanced CCTV coverage to monitor conditions, improving the ability of operators to manage the corridor, providing better information to motorists and quicker, more efficient responses to incidents. We have carefully designed these improvements such that geometric, drainage, and environmental aspects of the project do not result in a compromise to traffic flow or safety, which allows the maximum improvement to mobility and safety.

The results are 30 miles of PTS Use Lane, a reduction in travel time (55%), an increase in throughput (42%) and a decrease in density (38%), compared to No-build conditions.

iii. Discuss performance life of our Total Project; that is, the time it takes for congestion levels to return to preconstruction levels and the basis for our assessment of performance for all improvements, including static-dynamic median part-time shoulder.

The Corman Kokosing Team's design is based on achieving results in the future design year. We understand that while we achieved impressive results compared to future traffic volumes for No-build conditions, performance in the near term is important. On day one of the PTS Use Lane operation, there is an immediate improvement vs. the existing condition. This is a direct result of the additional capacity when the PTS Use Lanes are active and the additional improvements in our design. As time goes by and traffic volumes continue to increase, congestion levels increase.

We conducted an evaluation to determine the increase in volumes and the resulting performance measures over time, including MOEs for intermediate years 2025, 2030, and 2035. To compare each year, Travel Time, Throughput, and Density are used to compare intermediate years performance and to determine performance life of the project.

Based on that evaluation, our design will return to preconstruction levels by approximately the year **2030**.

While the immediate benefits of our improvements may seem limited, however this is actually quite impressive. Our design performance is compared to data gathered in 2018, a point in time. Once our design is constructed, traffic volumes on IS-695 will have grown four to five years. This amount of traffic increase is then using some of our newly-constructed capacity.

As presented in **Table 3-4**, as traffic volumes naturally grow over time, the performance of our design will decrease as more demands are placed on it. However, compared to 2040 No-build, our design performs much better, and increases in travel time and density occurs relatively slowly through 2035, and overall are much better than No-build in 2040 and beyond. Further, Throughput is near or above existing levels in most scenarios nearly to 2040, indicating that while there is much more traffic, the number of motorists that can travel the corridor is similar to existing. The interim year performance evaluation proves our design moves more motorists through the corridor faster, allowing them to be more mobile.



Interim Year Performance						
Inner Loop						
	Average Peak Hour Total Travel Time (min)		Average Hour Hour Throughput (pc/hr)		Average Peak Hour Density (pc/ln/mi)	
	AM	PM	AM	PM	AM	PM
Existing 2018	31.5	42.5	6,607	6,839	40.1	47.2
Proposed 2025	27.1	42.3	6,877	6,700	32.6	45.8
Proposed 2030	35.3	51.4	6,774	6,816	42.6	52.1
Proposed 2035	37.3	62.3	7,041	6,704	46.8	60.4
Proposed 2040	45.9	91.4	6,952	6,213	57.4	78.8
No-Build 2040	80.2	133.5	5,938	5,267	80.0	104.6
Outer Loop						
Existing 2018	57.5	36.6	6,529	6,799	65.5	43.9
Proposed 2025	46.5	31.5	6,763	6,910	50.0	37.7
Proposed 2030	58.8	46.8	6,769	6,721	62.8	54.9
Proposed 2035	72.7	54.1	6,725	6,471	74.7	60.1
Proposed 2040	90.5	92.0	6,414	5,927	89.8	83.5
No-Build 2040	235.6	166.6	4,012	4,655	146.5	131.9

Table 3-4: Performance of Interim Years Comparison

How Performance Life is Assessed: Performance life is a measure of how long it will take for our design to perform similar to the existing corridor’s performance. Traffic models of each interim year are used to develop MOEs – Travel Time, Throughput, and Density. MOEs for each interim year are then compared to the existing MOEs to see which interim year has worse MOEs than modeled existing conditions.



Our design moves more motorists through the corridor faster, which we have measured by throughput, travel time, and density, respectively. Performance life takes all three of these MOEs into account and as defined here, the end of the design’s performance life is the interim year which all three MOEs are worse than the existing year. Our design will continue to provide motorists with value through the design year **and well beyond** as shown in **Table 3-4** by the results achieved in 2040 compared to the No-build conditions.



MARYLAND DEPARTMENT
OF TRANSPORTATION™

STATE HIGHWAY
ADMINISTRATION



2.09.04 SAFETY

i. How our project detects/verifies non-recurring congestion along the IS-695 outer-loop/inner-loop between IS-70 and MD 43. Include how our project detects/verifies there are no obstructions in the static-dynamic median part-time shoulder areas prior to opening the shoulder for use and our proposed plan of action for MDOT SHA if an obstruction is detected. Include how our project detects/verifies and our proposed plan of action for MDOT SHA if a crash or obstruction is detected during the static-dynamic median part-time shoulder's scheduled operating window.

The Corman Kokosing | WSP | MC Dean Design-Build Team (Corman Kokosing Team) knows IS-695 can be a challenge for motorists. Existing traffic conditions inhibit mobility and reliability, and costs them valuable time. MDOT SHA has the daunting task of managing traffic conditions with limited resources and initiated this project to improve mobility and safety along the corridor not only for today, but into the future.

Adding a Part-Time Shoulder (PTS) Use Lane: A well-designed system of tools makes managing traffic conditions easier and improves mobility and safety. Our approach reflects our focus on both. The most effective method for improving safety is to improve mobility and the surest mobility improvement is to add capacity. This project focuses on adding a PTS Use Lane for the maximum length of the project corridor, including a comprehensive Intelligent Transportation System (ITS).

We propose to implement **30 miles** of static-dynamic PTS Use Lanes for the stipulated fixed price allocated for this project, among other improvements. Limits of the PTS Use Lanes are defined below and illustrated in **Figure 4-1**.

- ✓ Inner Loop: From IS-70 to Cromwell Bridge Road (15 miles)
- ✓ Outer Loop: From Cromwell Bridge Road to IS-70 (15 miles)

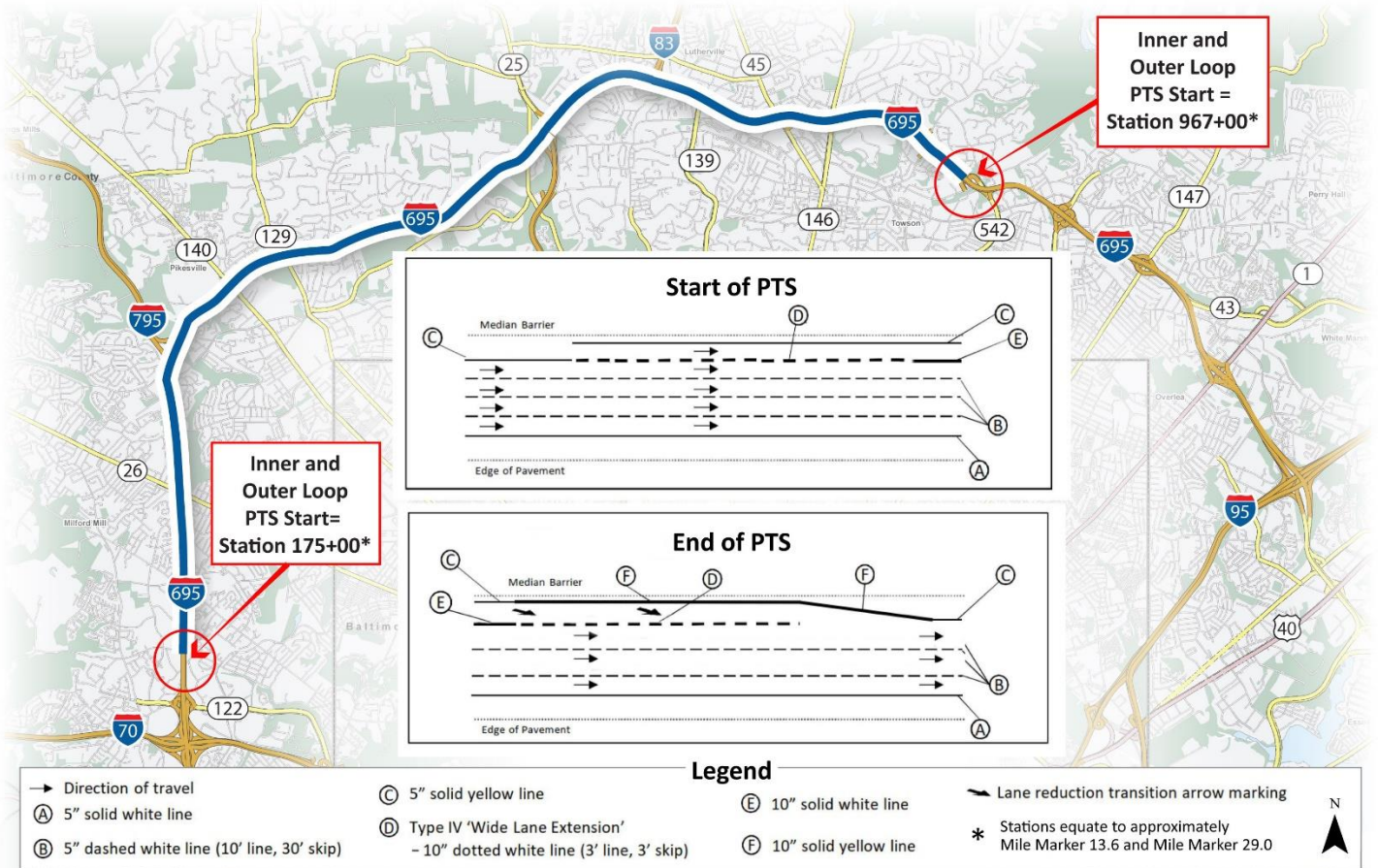

Figure 4-1: Our limits of PTS Use Lane and the typical striping geometry to start and end the PTS Use Lane

Out of a total project length of 35.78 miles (Inner and Outer loop), the Corman Kokosing Team's proposed PTS Use Lanes total **30 miles**, or approximately **80.5%** of the total available project limits.

Also presented in **Figure 4-1** are the starting and ending marking geometry for the PTS Use Lane. It will start with a 500-ft. Type IV *Wide Lane Extension*, 10-in. wide dotted white line (3-ft. line, 3-ft. skip) entrance before starting the PTS Use Lane with a solid 10-in. wide lane line. The yellow PTS edge-line adjacent to the barrier will also begin with the dotted entrance. Motorists can safely identify where the PTS Use Lane starts, and whether it is open or not via the Lane Use Control Signs (LUCS), and to safely enter.

Out of a total project length of 35.78 miles (Inner and Outer Loop), the Corman Kokosing Team's proposed PTS Use Lanes total 30 miles, or approximately 80.5% of the total available project limits.



BENEFITS: Adding the PTS Use Lane brings new flexibility in managing traffic. While it improves traffic flow during peak periods, limiting the potential for recurring congestion, the PTS Use Lane's hardware also detects/verifies non-recurring congestion, allowing MDOT SHA to quickly detect congestion as it is emerging and the flexibility to open the PTS Use Lane when needed to relieve it.

Detecting and verifying non-recurring congestion along the IS-695 Outer-Loop and Inner-Loop between IS-70 and MD 43: Our project is designed to detect and verify non-recurring congestion along IS-695 within the limits of our PTS Use Lane using a combination of cameras, sensors, and detectors placed overhead and along the roadside. This equipment quickly detects an incident occurring by monitoring the prevailing traffic conditions and identifying changes compared to historic or previously-measured conditions:

- ✓ **Automated Incident Detection (AID) Devices** collect data in the PTS Use lanes and general-purpose lanes and transmits the data collected back through ActiveITS to the Statewide Operations Center (SOC), where it can be analyzed/stored. Transmitted data includes traffic, such as travel speeds, throughput, and occupancy of each lane. AID also collects critical event data, such as stopped vehicles, fallen objects, pedestrians, and wrong way vehicles. AID devices will also send traffic alerts to operators when it detects changes in operational performance and incidents blocking shoulders and/or lanes.

Due to the critical nature and the role accurate data and detection plays in making traffic management decisions, our design uses top-of-the-line FLIR ThermiBot 2 cameras for all AID functions. We selected these cameras for their proven quality, such as low Mean Time to Detect (MTTD) and low False Alarm Frequency (FAF). For example, real world applications on similar roadways as IS-695 revealed FLIR thermal cameras can detect **pedestrians, stopped vehicles, and wrong way motorists** with **100%, 94.3%, and 100% accuracy** respectively, which are results you can rely on. **The FLIR camera's thermal imaging means detection is not interrupted by weather/environmental conditions – operators can count on getting reliable data no matter what the environmental conditions are.**

Our Team's Improvements:

- ✓ *Our proposed FLIR ThermiBot2 AID cameras have previously detected pedestrians, stopped vehicles, and wrong way motorists with 100%, 94.3%, and 100% accuracy (on similar facilities). These are results MDOT SHA can rely on.*

These cameras can also detect each individual lane covered by the field of view, sensing stopped traffic and objects. They support **detection of wrong way** motorists for quick detection/ response to these deadly types of incidents. Data collection/ detection allows managing the PTS Use and general-purpose lanes simultaneously, sending data to ActiveITS. Also, data is processed at each camera instead of at the local cabinet or centralized servers at MDOT SHA's server farm. This feature:



- Minimizes network traffic by reducing the amount of data transmitted from each AID device, reducing network-related slowdowns in receiving data.
- Unlike when a centralized cabinet is used and goes down, it prevents a large number of cameras to be down simultaneously, causing a mass outage in AID and data collection.

Our Team's Improvements will:

- ✓ *Not only provide 100% coverage of the PTS Use lanes but also provide coverage on approximately 65% to 75% of adjacent general-purpose lanes.*

Our design provides system operators with accurate traffic conditions, far beyond the system's required capabilities, allowing the most advanced technology to be their **eyes and ears**. This offers improved and faster decision making to effectively manage events. When changes in performance or incidents are detected, messages are sent to the Variable Advisory Speed Signs (VASS) and Dynamic Message Signs (DMS), with operator confirmation, to notify motorists of conditions ahead, promoting safe/efficient traffic flow. AID cameras are designed to provide 100% coverage of the PTS Use Lane. However, layout of the AID cameras and capability of the FLIR cameras also detects/monitors a large portion of the general-purpose lanes, allowing extensive monitoring of traffic flow conditions in the existing general-purpose lanes and ramps for about 65% to 75% of the travel area within the system implementation limits.

- ✓ **CCTV Cameras:** New CCTV cameras will be installed to supplement the existing CCTV layout and provide advanced visual coverage of the corridor, which increases MDOT SHA's awareness and improves probability that incidents or operational breakdowns are identified quickly. Operators can more easily assess/address the situation as policy and procedures dictate. Whether during recurring or non-recurring congestion, CCTV can assist the decision maker to alter electronic signs and signals along the corridor to maximize lane use, which optimizes throughput and minimizes travel times when speeds reduce. Our proposed CCTV cameras are mounted to camera poles, with lowering devices, supplementing existing camera coverage for a spacing approximately every 0.85 miles providing full CCTV coverage of the PTS Use Lane section and general-purpose lanes as required in the RFP. These are separate from any detector cameras and possess Pan-Tilt-Zoom (PTZ) functionality, with nearly a 360° viewing range. **However, to ensure multiple views are available when needed, our proposal adds an additional 12 CCTV cameras, with Pan-Tilt-Zoom functionality, within the PTS Use Lane section for an ultimate average spacing of 0.51 miles (double FHWA recommended density of one per mile and 40% more than the RFP requires!).**

ITS Layout: The Corman Kokosing Team has identified locations of the ITS equipment that balance system performance, with the ease of maintenance. For example, our design consolidates device communication points and controllers for ITS equipment into cabinets along the *outside* shoulder so that maintenance of multiple devices can be completed safely at one location without interrupting motorists. Our proposed ITS design was developed to not only meet the RFP requirement to detect and verify non-recurring congestion, but to exceed those requirements and maximize the system's ability to detect/report incidents while providing the best information for MDOT SHA to manage IS-695 as safely/efficiently as possible.

Our Team's Improvements will:

- ✓ *Detect traffic flow data and fallen objects and debris, pedestrians and other objects much smaller than a car.*

Our AID cameras are placed along the median, closest to the PTS Use Lane with an unobstructed view of the lane with no chance of occlusion due to large vehicles. They are carefully spaced for 100% coverage of the PTS Use Lane around bridges and other structures, eliminating even minor blind spots and simultaneously providing detection for a large portion of the adjacent general-purpose lanes.

To mitigate the naturally-occurring blind spot directly adjacent to the camera mounts, we designed our system to provide coverage of those blind spots. The proposed equipment detects traffic flow data and objects and debris in this overlap, pedestrians and other objects much smaller than a car.

AID camera parameters, along with the RFP requirements and our attention to detail, have guided us to our proposed design to detect and verify non-recurring congestion. It also considers how the AID and CCTV cameras are used collectively to detect and verify there are no obstructions in the shoulder, prior to opening the shoulder as a PTS Use Lane. As shown in **Figures 4-2 and 4-3** below, the AID devices are generally oriented to face the same direction along the corridor, detecting both travel directions simultaneously. This gives us the most efficient design in that it maximizes coverage while minimizing devices. However, in some cases, we mounted AID cameras back-to-back on the same pole so the cameras' viewshed overlaps under bridges, eliminating the possibility of a blind spot under it due to the bridge deck and mounting height of the camera. In other cases, an additional AID camera is mounted on the upright of an existing sign structure, either in the median or on the outside of the roadway.

The purpose of the AID camera is to cover the blind spot that is created when two cameras are mounted together on the same pole. The additional camera has a smaller area to cover and can be mounted lower than the rest. Advantages are that we take advantage of the existing structures AND eliminate blind spots.

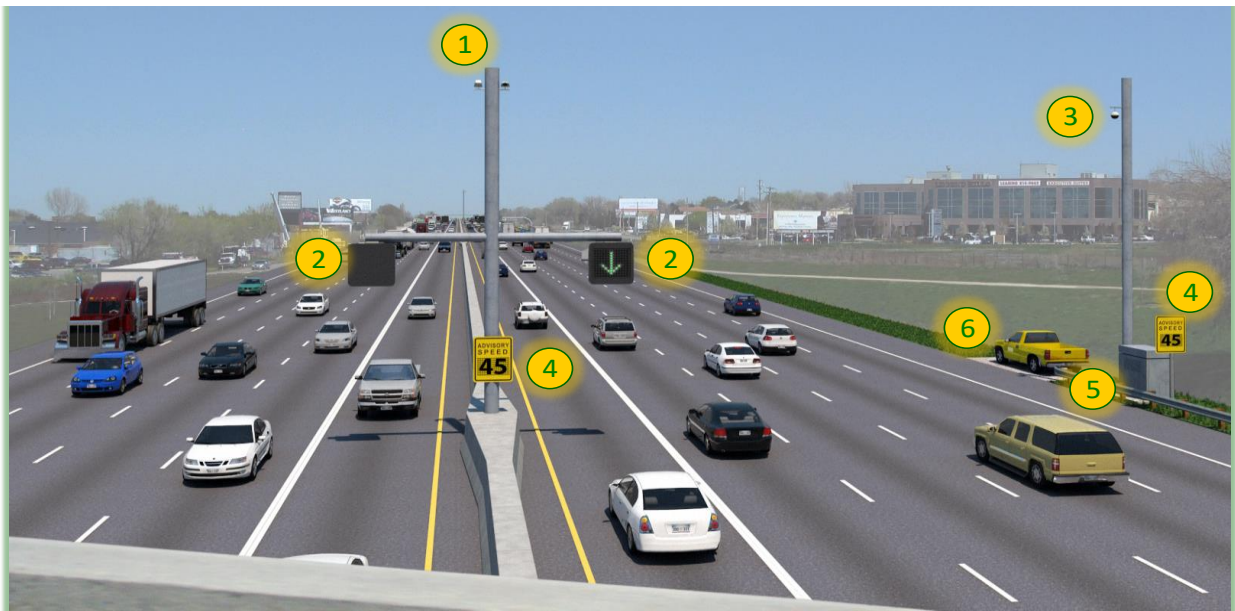

- ① - Automated Incident Detection Camera (AID)
- ② - Lane Use Control Signal (LUCS)
- ③ - CCTV Camera
- ④ - Variable Advisory Speed Sign (VASS)
- ⑤ - ITS Cabinet
- ⑥ - ITS Cabinet maintenance pull-off

Figure 4-2: Typical ITS implementation layout

The FLIR cameras also send traffic event alerts when it detects changes in operational performance and incidents blocking shoulders and/or lanes. Our AID implementation gives operators a *traffic condition image* far beyond what the present system is capable of, allowing technology to be their **eyes and ears**. This generates better, faster decision making to quickly apply MDOT SHA procedures to manage events. Additional details on these detectors is provided within **PTC's #1R2 and 2R2**.



CCTV cameras provide MDOT SHA with coverage to visually verify non-recurring congestion. AID cameras sense changes in traffic and detect objects, however, they may not provide context as to the cause of these events or the response required.

We included CCTV cameras along the outside the roadway for 100% view of the PTS Use Lanes per RFP requirements. However, the role of the CCTV cameras is critical in operating, not only the PTS Use Lanes, but the entire roadway width.

LUCS are placed to give motorists clear direction as to whether the PTS Use Lane is open or closed. They are designed for two different LUCSs to be visible at any one time while traveling in the PTS Use Lane. For straight sections of IS-695, they are proposed at a maximum spacing of 2300-ft.; the maximum required viewing distance in the *Manual on Uniform Traffic Control Devices* (MUTCD), as applicable or required. However, curves and bridges require much more closely-spaced LUCSs to ensure two are visible to motorists at all times. Minimum spacing for LUCSs is approximately 640-ft. to compensate for obstructions and roadway curvature. This gives motorists clear, consistent information on the status of the PTS Use Lane allowing them to make better decisions and reduces the potential for sudden maneuvers that cause crashes and impacts traffic flow, further reducing the risk for non-recurring congestion.

Figure 4-3 shows a section of our preliminary proposed layout utilizing the spacing criteria above. The green area shows the approximate view of each camera. It also shows that our AID cameras cover approximately 65% to 75% of the general-purpose lanes as well as on and off ramps. Using separate detection zones for each lane. Because of the quality of AID camera we've selected, we can also collect the full range of traffic data, such as travel speeds, throughput, and occupancy of each lane and critical event data such as stopped vehicles, fallen objects, pedestrians, and wrong way vehicles in PTS use lanes, general purpose lanes, and on and off ramps.

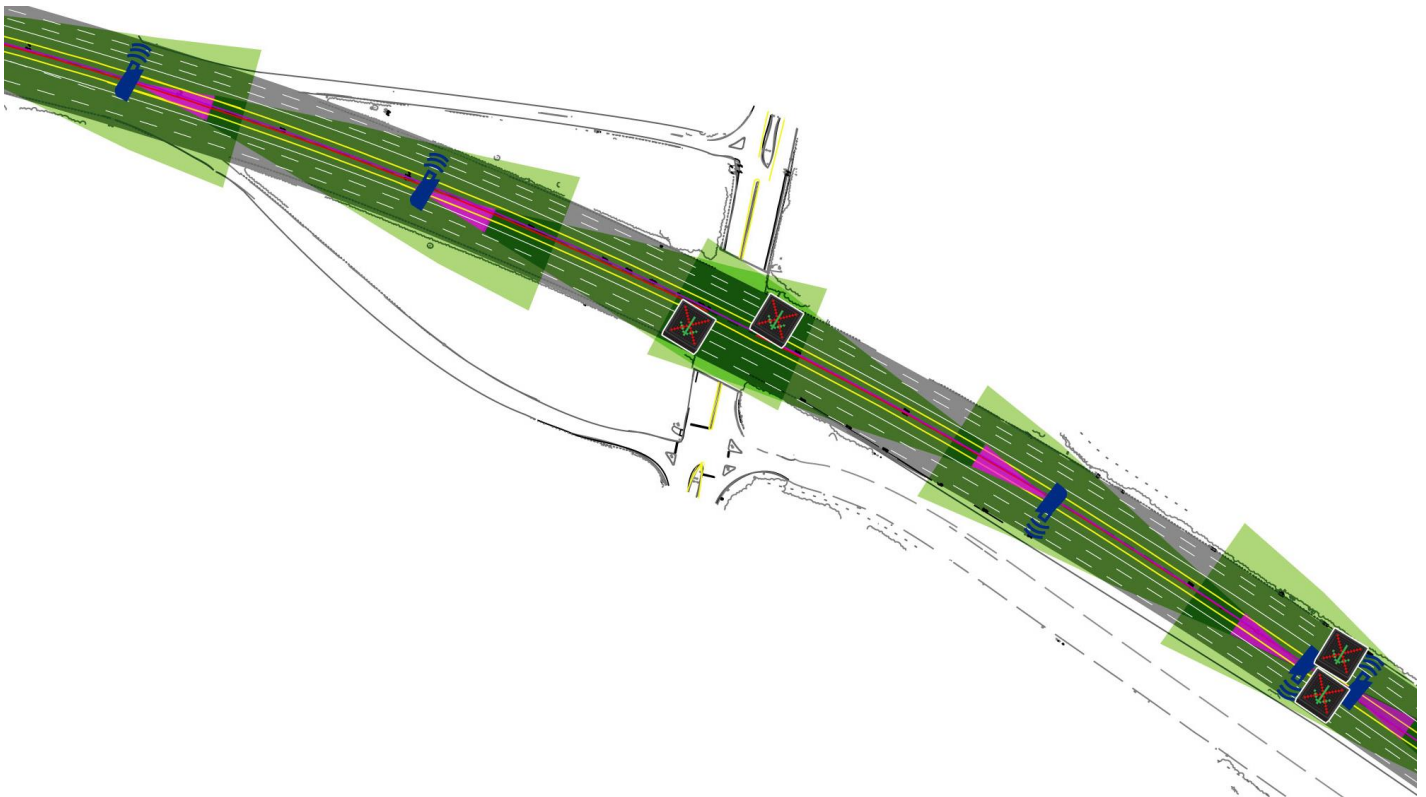

Figure 4-3: Preliminary Proposed ITS Layout

Detecting and Verifying PTS Use Lane when prepared to open: Our proposed ITS is designed to monitor the PTS Use Lanes while open and closed. The system uses the detection capability and frequent spacing of AID cameras designed to support the safe operation of the lane. AID cameras can detect objects in the road, such as pedestrians, animals, objects, and vehicles that may prevent opening the PTS Use Lane.

Prior to opening, whether the PTS Use Lane is on a static schedule or operating dynamically, the following verification process must be followed to assure there are no hazards that would prevent using the lane:

- ✓ Verify there are no alarms from AID cameras
- ✓ Visually confirm there are no objects, obstacles, or incidents in the PTS Use Lane using CCTV

Figure 4-4 illustrates our *Decision Flow Chart* for opening the PTS Use Lane. Once determined it will open, either due to scheduled operation or as added capacity during non-recurring congestion, our proposed decision process is the following :

1. PTS Use Lane is initially closed
2. AID cameras are checked to verify no alerts were sent for detected objects/incidents
 - If there are alerts, crews are deployed to clear object, proceed to #4; incidents follow incident response policies and procedures
 - If no alerts, PTS Use Lane remains closed and proceed to #3
3. SOC operators use CCTV cameras to confirm there are no obstructions within the PTS Use Lane as a final verification it is ready to open:
 - If no obstructions, open PTS Use Lane
 - If there are obstructions, PTS Use Lane remains closed and proceed to #4
4. Deploy crew to remove obstruction and start process again with #2

In addition, general-purpose lane operation is verified through AID and CCTV cameras. If traffic flow is reduced compared to normal time of day operations or an incident is detected in the general-purpose lanes, a decision must be made by the SOC operators whether to open the PTS Use Lane for the detected conditions.

Once the all clear has been visually verified, LUCS displays are changed from a Red "X" to a Green "↓", indicating the lane is now open to traffic. During this time, SOC operators continue to monitor AID and CCTV cameras, monitoring traffic flow in the PTS and general-purpose lanes throughout the PTS Use Lane operational window.

Decision Flow Chart for Opening PTS Lane
(includes detecting incident when PTS is closed)

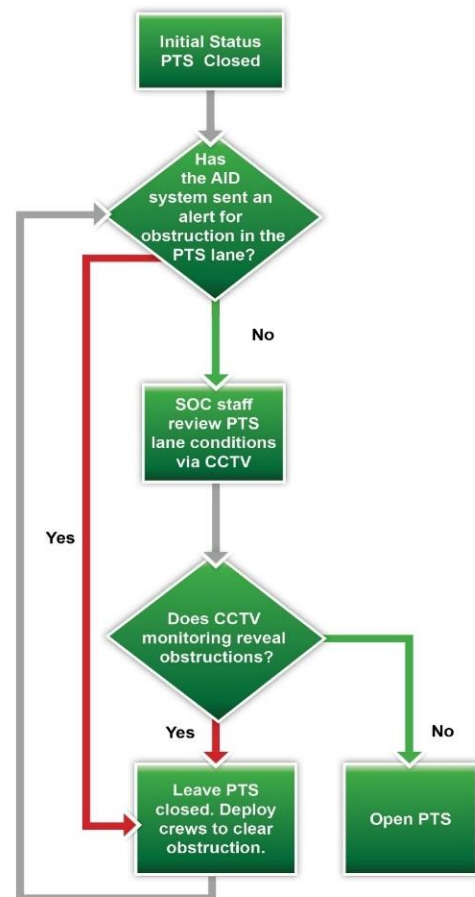
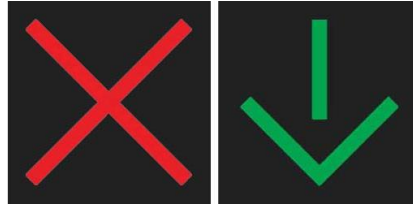

Figure 4-4: Decision Flow Chart for Opening PTS Use Lane



If at any time during this process an incident/event is detected that impacts traffic flow, the system sends an alert to the SOC operators, where the right mitigation strategy can be applied, based on the incident parameters and per MDOT SHA policies and procedures.

If an object is detected in the median shoulder area when preparing to open the PTS Use Lane, the MDOT SHA Emergency Patrol crews are deployed to remove the object and clear the hazard. Once they verify reported objects have been cleared, the process for opening the PTS Use Lane is repeated from the beginning by verifying there are no alarms from the AID cameras until the entire verification can be complete.

If an incident or hazard is reported in an adjacent general-purpose lane, opening the PTS Use Lane depends on the nature of the event and location. For an event affecting a small area in the outside (right) general-purpose lanes, opening the PTS Use Lane can relieve congestion and may already be partially open as part of incident response procedures. However, if the event is severe, the PTS Use Lane may remain closed to prevent traffic from using the left shoulder and to provide space for emergency access to the area.

Incident or Object Detected While PTS Use Lane is Already Open: If an object or incident is detected in any lane, including PTS Use and general-purpose lanes, while the PTS Use Lane is open, the response depends on the nature or location of the incident. In some cases, the nature or location will preclude using the PTS Use Lane. This applies to incidents on the median side of the roadway that may block the PTS Use Lane and/or adjacent general-purpose lane. In this case, motorists approaching the object or incident can be directed to the right lanes of IS-695 through DMS messages as MDOT SHA policy dictates. In addition, starting approximately one mile before the incident, LUCSs display a Yellow “X”. At least two consecutive LUCSs will display a Yellow “X” for approximately ½ mile. Within approximately ½ mile from the incident at least two consecutive LUCSs will display a Red “X”. After the incident at least one LUCS will display a Red “X” before motorists see the normal Green “↓” indicating the PTS use lane is again available for use.



This accomplishes two things:

1. It alerts motorists that the PTS Use Lane is closed and to merge to the right.
2. It clears a route for emergency responders in route to the scene.

Depending on the severity of the incident, the emergency response required, and the level of congestion the incident is creating, the number of LUCSs the Red “X” is displaying on may need to be increased to raise the amount of closed PTS Use Lanes around the incident. These decisions are ultimately based on SOC Operator communication with the response team at the incident and MDOT SHA policies and procedures.

In other cases, the nature or location of the incident benefits from using PTS Use Lane. This applies to incidents on the outside of the roadway that may block the right shoulder and/or right general-purpose lanes. Motorists approaching the



object/incident can be directed to the left lanes of IS-695 through DMS messages and the PTS lanes potentially opened, as MDOT SHA policy and procedures dictate.

Variable Advisory Speed Zones: In our ITS design, we are proposing Variable Advisory Speed Zones, also known as **speed harmonization**, to serve dual roles for almost 14-miles of the project limits, as presented in **Figure 4.5**. They will supplement operation of the PTS Use and general-purpose lanes. Operation is the same for both roles; once the system detects an event, speeds are reduced to a certain threshold and the system automatically adjusts the VASS to advise motorists of congestion ahead and to lower travel speed.

As speeds start to reduce in peak travel periods, speed harmonization is implemented by activating the VASS, which gradually slows motorists over a longer distance before the congested area and maintains more consistent speeds within congested locations. This reduces the risk of more severe congestion and improves the recovery time to free flow conditions. As congestion starts to recede, the VASS can be adjusted similarly to achieve maximum traffic flow and highest safety.



Figure 4-5: VASS Zones

This system is important when a crash or obstruction is detected while the PTS Use Lane is open during its normal operating schedule. The VASS serves as another indicator that non-recurring congestion is occurring and where, as they automatically display advisory speeds. Not only do they give motorists advanced notice that there is a traffic event and to be aware, the resulting reduction in travel speeds approaching incidents will help prevent rear end crashes, a profound safety benefit of the VASS.

Variable Advisory Speed Signs (VASS): This uses VASS in groupings through ActiveITS, MDOT SHA’s corridor Active Traffic Management System (ATMS), to provide speed advisories to motorists before approaching congestion. VASS are placed in pairs; one in the median and one on the outside with each pair spaced approximately ½ mile apart. Additional details are provided within **PTC #10**. Speed advisories are displayed based on real-time data from detection. The Corman Kokosing Team’s concept is to display advisory speeds of either 45-mph or 35-mph; however, our system is capable of 5-mph increments and we will work collaboratively with MDOT SHA to establish the preferred operation of the system.

As roadway congestion is detected and travel speed is reduced to a threshold, 45-mph will be displayed in pairs approaching the congested area. If congestion continues to build and reaches a second threshold, 35-mph will be displayed on one or more groups of VASS. Upstream of the first 35-mph VASS displays, 45-mph will be displayed as a transition from posted speed to an advisory speed (**See Figure 4-6**).

Within each variable speed zone, advisory speeds are posted from downstream to upstream such that, as congestion builds, the 35-mph advisory is displayed on more VASS, moving upstream concurrently ahead of the point of congestion. The first advisory viewed by traffic is always the 45-mph to provide a transition into 35-mph. Variable advisory speed zones and VASS placement were selected based on the VISSIM traffic modeling, which identified locations where VASS implementation has the greatest benefit to mobility.

Posting advisory speeds is a dynamic process using algorithms within a pre-developed module of ActiveITS. This module seamlessly integrates into ActiveITS.

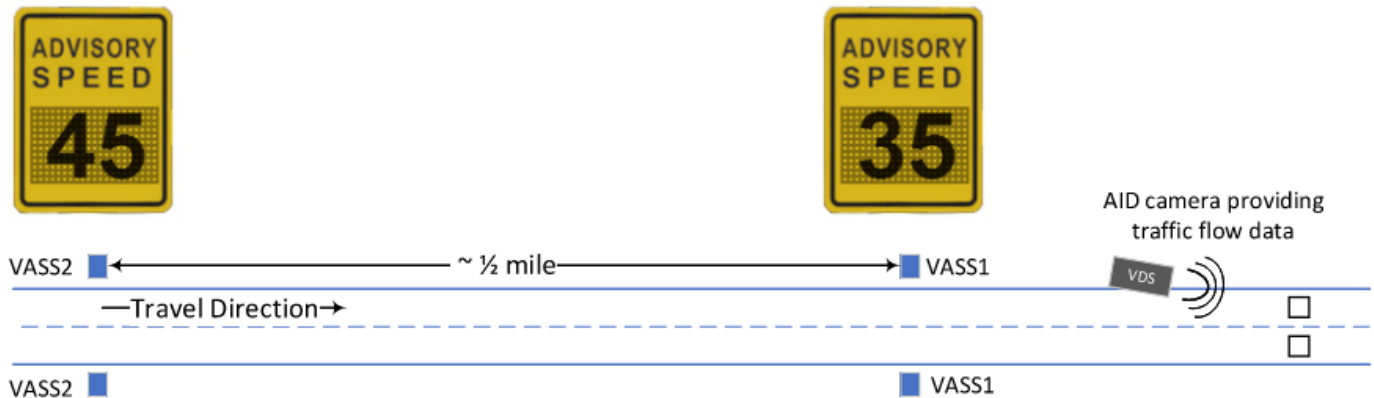

Figure 4-6: Typical VASS Layout

Purchase, integration, and testing of the module will be provided at no cost to MDOT SHA and is included in our proposal. Although the thresholds and algorithms for posting advisories will be developed during final design, coordinated with MDOT SHA and Southwest Research Institute (SwRI), conceptually, the process the module uses to determine if an advisory speed is appropriate and what speed is displayed is shown as a *Decision Tree* (**See Figure 4-7**). The decision is based on two speed thresholds compared to collected field data from the AID cameras. Those thresholds trigger a 45-mph or a 35-mph display. The thresholds are anticipated to be 50-mph and 40-mph, however, that is determined during final design with MDOT SHA and can be modified at any time after implementation but revising the thresholds utilized in the software.

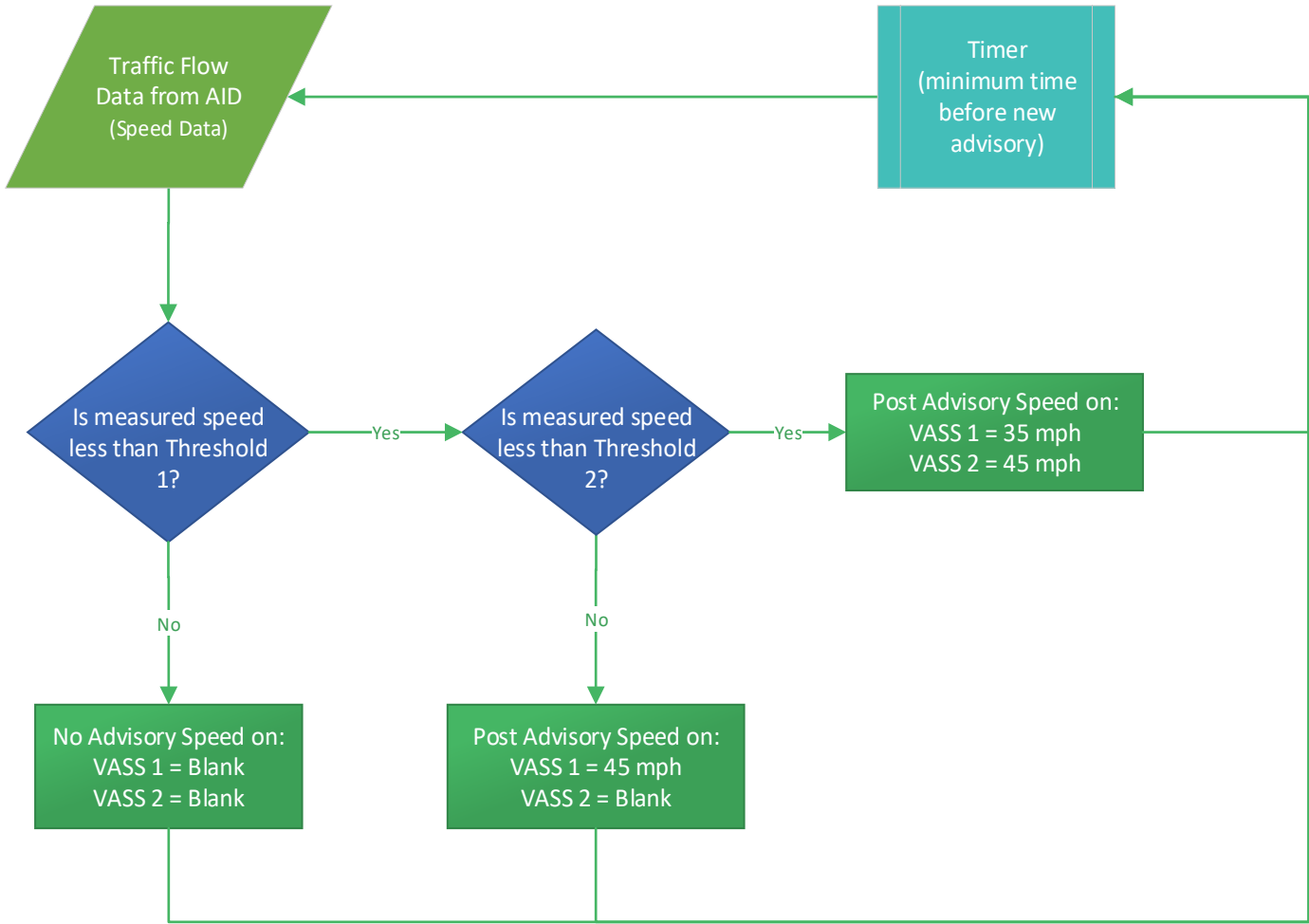

Figure 4-7: Speed Advisory Display Decision Tree

Once a threshold has been met and the system determines an advisory speed will be posted, an alert is sent to the Statewide Operations Center (SOC). This alert allows the operator to override the VASS system or, when warranted, permits messages to be displayed by CHART on existing DMS signs prior to the VASS to alert motorists of upcoming congestion.

In addition, on-ramps within a Variable Speed Zone will include a VASS along the ramp and mimic the display of the prevailing mainline VASS. The purpose here is to advise entering traffic of congestion ahead and to reduce speed and approach with caution. Much like the Speed Advisory Zones, motorists will reduce speed more gradually and more consistently with each other, which minimizes the frequency/extent of congestion and potential for rear end collisions that typically occur with more severe deceleration over shorter distances.

MDOT SHA can manually post speed advisories further in advance of an incident for added flexibility in managing events and maintaining a more consistent travel speed through the corridor.

ii. How our improvements allow MDOT SHA CHART to better respond to and manage non-recurring congestion along the IS-695 outer-loop and inner-loop between IS-70 and MD 43.

Our project is designed to detect and verify non-recurring congestion along IS-695 between IS-70 and MD 43 using a combination of cameras, sensors, and detectors placed overhead and along the roadside. The goals of detection are to identify non-recurring congestion as (or before) it occurs and quickly determine location and severity. For incidents, it is to minimize response times by emergency responders, including State and County police, fire, and emergency medical services (EMS) and to minimize the time it takes to clear the incident.

Informing Motorists: Our design supports MDOT SHA’s policies and procedures for managing both types of non-recurring congestion by providing superior data that can then be used to inform the public of increasing congestion or determine when and where incident responses must be deployed. Superior information from the field leads to superior decisions for MDOT SHA, saving motorists time, stress, and lives. The system also detects other obstructions (i.e., debris, animals, standing water), by sensing traffic flow conditions (i.e., speed, lane use, and traffic density). In addition, our system includes **wrong way detection** for PTS Use and general-purpose lanes.

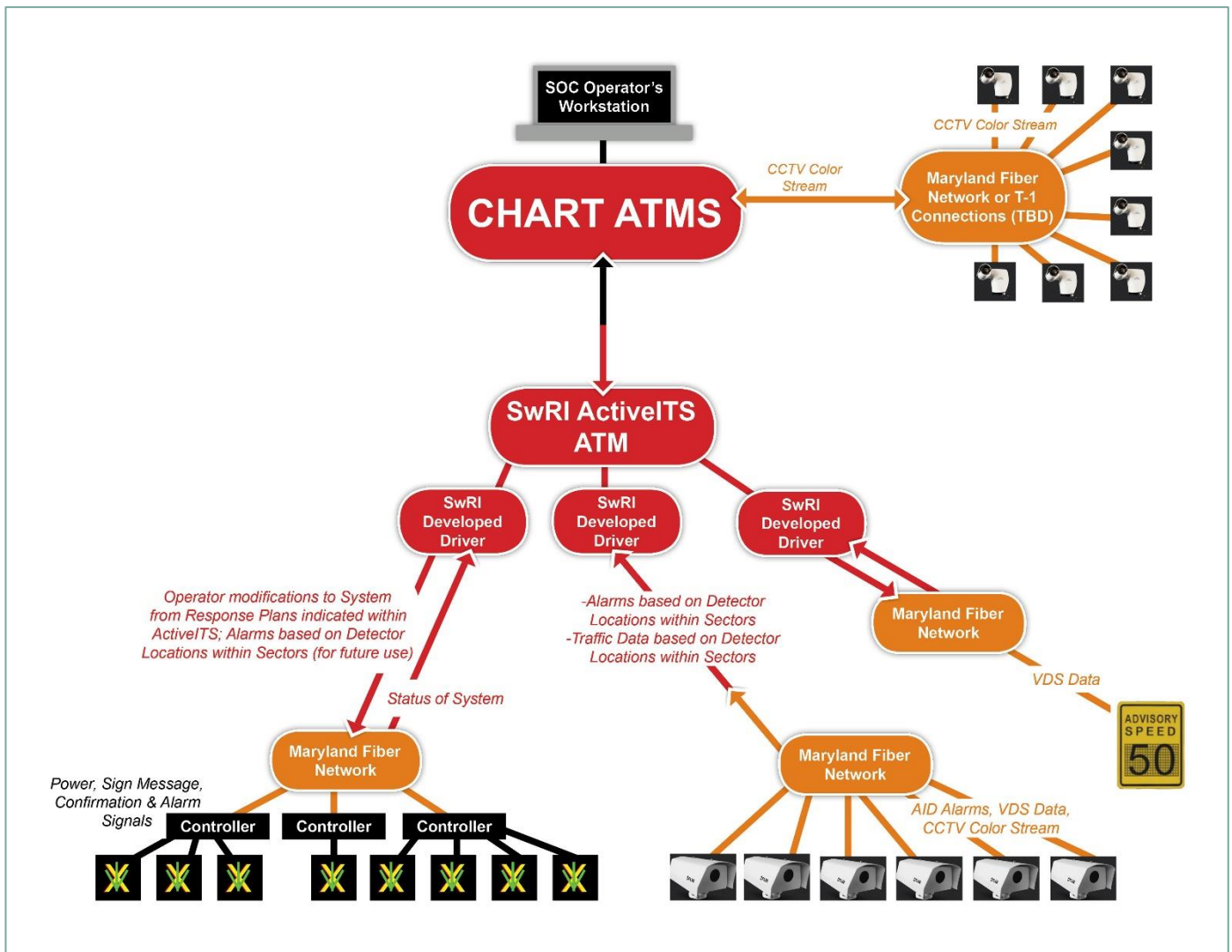

Figure 4-8: Control Operational Concept

MDOT SHA has established policies and procedures for managing non-recurring congestion. By receiving improved information from field devices means that congestion can be detected more accurately and faster, allowing these policies and procedures to be applied when they are most effective and not after congestion has already worsened. How this data flows from field devices to the SOC is important. **Figure 4-8** shows the network topology of our design and how field data is transmitted to the appropriate device controllers. Data from the AID cameras is collected and processed at each individual camera and sent through the fiber network from a local ITS cabinet. Because the data collected is processed by each camera, data transfer through the network is smaller and more manageable. This will prevent potential network slowdowns due to the amount of data, allowing it to be transmitted to MDOT SHA more quickly.

Data is transferred through the fiber network to ActiveITS. New required ActiveITS modules have licensing fees that are included in our proposal **for three years** that allow the enhanced functionality our *top-of-the-line* detectors are providing. ActiveITS communicates back and forth between field devices, such as LUCS and VASS. ActiveITS is where the VASS displays are determined and automatically changed to provide congestion speed advisory. The LUCS are also controlled by ActiveITS; however, opening/closing the PTS Use Lanes begin as a manual MDOT SHA process with the ability/intention to move to a more dynamic process in the future, allowing ActiveITS to automatically open/close the PTS Use Lane based on future policies and procedures. This gives MDOT SHA a balance between controlling the system and allowing the system more control to quickly respond to incremental changes in traffic conditions.



BENEFIT: The flexibility to migrate to an automated system as conditions dictate is a powerful aspect of our design, helping MDOT SHA reduce and manage non-recurring congestion.

MDOT SHA currently has a communication path between ActiveITS and Chart ATMS so CHART ATMS can receive messages and monitor status of ActiveITS. This will not change. Chart ATMS will continue to manage DMS messaging along the corridor. However, our design allows enhanced messaging, such as advisories for non-recurring congestion, based on measured traffic conditions.

Existing DMSs will be used similar to their current operation as MDOT SHA policies and procedures dictate, but with connectivity to additional detectors, sensors, and cameras. Messages can then be more consistent and quickly updated as conditions change. They can supplement operation of the AID devices and VASS and expand the number and type of messages that can be displayed as motorist information to maximize advanced decision-making. DMSs will continue to provide messages, but will have the ability to enhance that messaging based on the new capabilities of the system.

Our ITS (AID/LUC/DMS) design provides opportunities to reduce crashes that can result from non-recurring congestion. By using VASS and other warning, advisory, and guidance messages, motorists are notified ahead of time to reduce speed. With consistently reduced speeds for the majority of approaching motorists, any secondary crashes are likely be lower in number as well as severity – situations that typically result in fatalities are more likely to result in injuries or property damage only (PDO), and injury-prone situations are more likely to result in PDO.

Speed harmonization using VASS also reduces expected crash severity/risk for motorists before approaching an incident, as lower speed variability reduces the chance of rear-end collisions and the need to change lanes quickly, which is associated with sideswipes. Our system positions MDOT SHA to better respond and manage incidents when they occur, reducing the length of time and how severely traffic flow is impacted.

In addition to superior field data, our design provides superior CCTV cameras coverage; 129% more cameras than existing, to provide MDOT SHA enhanced ability to monitor and verify traffic conditions in real time, offering layers of coverage. Although CCTV requires monitoring by MDOT SHA, the added visual coverage of the corridor helps reduce the time between when an incident occurs and notifying emergency responders. Our enhanced coverage also provides multiple views allowing



operators to dispatch the correct response more quickly, again reducing impacts non-recurring congestion has on traffic flow and safety, including the decision by MDOT SHA to open or close the PTS Use Lane outside of typical operating hours.

The following three scenarios are examples of how MDOT SHA will use our ITS design to better respond and manage non-recurring congestion:

Scenario 1 / Managing an incident during non-peak hours (PTS Use Lane closed)

Here, two general-purpose lanes are closed during non-peak hours for an incident, while the PTS Use Lane is closed to traffic.

1. The AID detects the incident and sends an alert to the SOC.
2. SOC operators verify the incident through CCTV cameras, which can now view the incident from multiple angles, and dispatches appropriate emergency response.
3. SOC operators then dispatches the response based on policies and procedures, providing valuable information on the condition of the scene. Information from detectors and CCTV is provided to the response team to advise where the incident occurred and how to best access the site.
4. As a minimum the next two DMS upstream are posted with advisories warning motorists of an incident ahead and, if necessary, suggesting an alternate route per MDOT SHA policies and procedures.
5. VASS detection senses a slowdown in traffic and automatically posts advisory speeds approaching the incident, which is verified through the enhanced CCTV coverage.
6. Based on information from the scene and the ITS, SOC operators decide opening the PTS Use Lane will mitigate traffic impacts caused by the incident.
7. SOC operators verify the PTS Use Lane is clear through AID and CCTV coverage and prepare to open the PTS Use Lane for additional capacity.
8. SOC operators change the LUCS starting approximately one mile before the backup caused by incident. At this point, a Green “↓” is displayed on LUCSs through the area of the incident, indicating the PTS Use Lane is open. Downstream of the incident, at least two consecutive LUCSs display a Yellow “X” for approximately ½ mile. After the last Yellow “X”, LUCSs all display a Red “X” indicating the PTS Use Lane is closed and no longer available.

Depending on the severity of the incident, emergency response required, and level of congestion the incident is creating, the number of LUCSs that the Green “↓” is displaying on may need to be increased to increase the length of open PTS Use Lanes around the incident. These decisions are ultimately based on SOC operator’s communication with the emergency response team at the incident and MDOT SHA policies and procedures, including the need for emergency response to utilize the PTS Use lanes to access the incident.

Incident clearance times will also be lower as the impact of congestion on incident management is less since there is additional capacity for traffic. The additional capacity reduces congestion compared to that anticipated under normal conditions and provides more flexibility in active traffic management approaching through and beyond the incident scene. Although VASS will reduce speeds approaching the incident, the ultimate reduced speed immediately upstream of and through the incident area will be higher, thus reducing the length of the rolling queue and impact of the shockwave from reduced speed. The combination of reduced approach speeds and higher speeds through the incident area reduces additional crash risk.

After the incident is cleared, the time to return to pre-incident flows and speeds is quicker than under existing conditions because of the improved quality of traffic flow in the area of the incident while the lanes are blocked.

Scenario 2 / Managing an incident during peak hours (PTS Use Lane open)

Here, one general-purpose and the PTS Use Lanes are closed during peak hours for an incident, when the PTS Use Lane is open to traffic.

1. The AID detects the incident and sends an alert to the SOC.

2. SOC operators verify the incident through CCTV cameras, which can now view the incident from multiple angles, and dispatches emergency response.
3. SOC operator then dispatches the response based on policies and procedures, providing valuable information on the condition of the scene. Information from detectors and CCTV is provided to the response team to advise where the incident occurred and how to best access the site.
4. At a minimum the next two DMS upstream are posted with advisories warning motorists of an incident ahead and, if necessary, suggesting an alternate route per MDOT SHA policies and procedures.
5. VASS detection senses a slowdown in traffic and automatically posts advisory speeds approaching the incident, which is verified through the enhanced CCTV coverage.
6. Based on information from the scene and ITS, SOC operators determine that a portion of the PTS Use Lane must be closed due to the incident.
7. SOC operators change the LUCS starting approximately one mile before the incident. At this point, at least two consecutive LUCSs display a Yellow “X” for approximately ½ mile. Within approximately ½ mile from the incident, at least two consecutive LUCSs display a Red “X”. Downstream of the incident at least one LUCS displays a Red “X” before motorists see the normal Green “↓” indicating the PTS Use Lane is again open.

Depending on the severity of the incident, emergency response required, and level of congestion the incident is creating, the number LUCSs that the Red “X” is displaying on may need to be increased to raise the amount of closed PTS Use Lanes around the incident. These decisions are ultimately based on SOC operator’s communication with the response team at the incident and MDOT SHA policies and procedures.

With the PTS Use Lane available and open to traffic, MDOT SHA CHART and emergency service response times will be lower than under existing conditions with only general-purpose lanes and right shoulder available for use. Incident clearance times will also be lower, as the impact of congestion on incident management is less since there is additional capacity for traffic. The additional capacity reduces congestion compared to that anticipated under normal conditions and provides more flexibility in active traffic management approaching through and beyond the incident scene. Although VASS will reduce speeds approaching the incident, the ultimate reduced speed immediately upstream of and through the incident area will be higher, thus reducing the length of the rolling queue and impact of the shockwave from reduced speed. The combination of reduced approach speeds and higher speeds through the incident area reduces secondary crash risk.

After the incident is cleared, the time to return to pre-incident flows and speeds is quicker than under existing conditions because of the improved quality of traffic flow in the area of the incident while the lanes are blocked.

Scenario 3 / weather event reducing traffic flow during peak-hours (PTS Use Lane open)

In this scenario, deteriorating conditions due to a weather event (i.e., fog, heavy thunder storms) causes a slowdown in traffic flow during peak-hours when the PTS Use Lane is open, causing congestion.

1. The AID and VASS detectors sense traffic slowing down and traveling closer together.
2. VASS starts posting advisory speeds, warning motorists that conditions ahead have changed.
3. A message/notification is sent from AID cameras to SOC operators that congestion has been detected.
4. SOC operator verifies the conditions through CCTV cameras, confirming congestion is not incident related, but a change in environmental conditions.
5. SOC operator informs crews of deteriorating conditions to be ready for dispatch, following MDOT SHA policies and procedures.
6. DMS in the corridor are posted with advisories warning motorists of deteriorating conditions and advise caution and lower speeds per MDOT SHA policies and procedures.

Weather events are unavoidable. The best response to managing the resulting non-recurring congestion is to advise motorists and be prepared. Early detection provided by our system enhances MDOT SHA’s ability to sense events in real time, providing



early detection and allowing more time to respond and manage conditions. Without the sensors, operators are at a disadvantage in making decisions with limited information. Our system provides them the information they need...when they need it...to respond faster and better manage the situation.

iii. Our proposed plan of action for MDOT SHA to determine if the static-dynamic median part-time shoulder use should be activated outside its scheduled operating window to allow for additional capacity when there is an incident in one or more through lanes on IS-695, our proposed plan for how MDOT SHA operators should determine what portion of part-time shoulder should be used for the incident and our proposed plan of action for how MDOT SHA opens and closes the shoulder.

Our design provides MDOT SHA with additional tools to manage the growing traffic volumes along IS-695, improving the mobility and safety of tens of thousands of motorists every day. By simply adding a significant length of PTS Use Lane, additional capacity is available and will reduce congestion during the peak hours when it is need most. Our ITS design includes many features to help it operate smoothly and safely to accomplish these goals. Further, when unexpected events occur, from weather events, to traffic incidents, to unexpected high traffic volumes, our ITS design also helps MDOT SHA determine when the PTS Use Lane will mitigate these traffic impactors by providing information quickly and accurately to the SOC. There, the data and MDOT SHA policies and procedures are considered in determining when to open the PTS Use Lane for motorists.

How to Decide if the PTS Use Lane Should be Opened Outside of Normal Operating Hours: Determining if the PTS Use Lane should be opened outside of scheduled operating hours when an incident occurs is based on thresholds and detection along the IS-695 corridor. In general, this decision needs to be made due to an event that impacts traffic flow. AID cameras detect a change in traffic flow within the general-purpose lanes. This could be the result of weather, a crash, an object in a lane, heavy traffic from a local event, or various other causes. The AID transmits data to ActiveITS and SOC operators (AID equipment covers approx. 65% to 75% of the general-purpose lanes and is in operation even when the PTS Use Lanes are closed.) The data, for example, average speed or density, are compared to predetermined thresholds based on what traffic conditions are anticipated to be vs. what they are measured to be. These thresholds determined by MDOT SHA policies and procedures, including when to open the PTS Use Lane and how much of it to open. The process is similar to VASS automatically posting advisory speeds, but using a range of data and a process for SOC operators.

Enhanced CCTV cameras are used to view multiple angles of the traffic flow, providing additional information to determine the need to open the PTS Use Lane, the nature of the event, and how to respond.

Our design supports this decision-making process by providing a continuous stream of data, such as travel speeds, throughput, and occupancy of each lane, for all general-purpose lanes. When one or more of these measures change to the predetermined threshold, then the PTS Use Lane open process should be considered. Our enhanced CCTV coverage, which adds eighteen (18) cameras, (provides 0.51-mile vs RFP required 0.85-per mile density) provide visual support from multiple angles to support this decision-making. Our VASS system sends alerts to operators that an event is occurring and is actively working to mitigate the impacts. These alerts also support the decision-making. By using all of the tools in our design, MDOT SHA's management of the IS-695 corridor, including when to open the PTS Use Lane outside of normal operating hours, gets easier.

How Much of the PTS Use Lane Should be Opened: Part of the decision for opening the PTS Use Lane is to open the entire lane, for events that affect the entire corridor, or to open part of the lane based on an incident location and severity. If an incident is detected, SOC operators use our enhanced CCTV coverage to visually monitor the incident, determine a response, and how much PTS Use Lane should be open. For many incidents, a baseline method is suggested and should be modified as needed and become part of MDOT SHA's policies and procedures.

SOC operators change the LUCS starting approximately one mile prior to the opening of the lane. At this point, a Green "↓" is displayed on LUCSs through the area of the incident, indicating the PTS use lane is available for use. Downstream of the

lane's need, at least two consecutive LUCSs display a Yellow "X" for approximately ½ mile. After the last Yellow "X", LUCSs will all display a Red "X" indicating to the motorists that the PTS use lane is closed and no longer available for use.

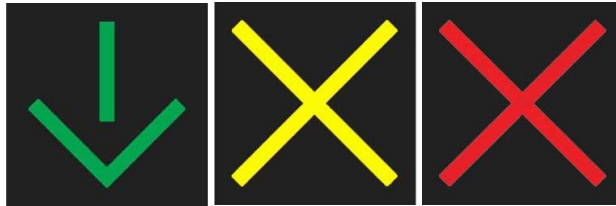

Depending on the severity of the incident, emergency response required, and level of congestion the incident is creating, the number LUCSs that the Green "↓" is displaying on may need to be increased to raise the amount of open PTS Use Lane around the incident. These decisions are ultimately based on SOC operator's communication with the emergency response team at the incident and MDOT SHA policies and procedures.

With the PTS Use Lane available and open to traffic, MDOT SHA CHART and emergency service response times will be lower than under existing conditions with only general-purpose lanes and right shoulder available for use. Incident clearance times will also be lower, as the impact of congestion on incident management is less since there is additional capacity for traffic. The additional capacity reduces the severity of congestion compared to that anticipated under normal conditions and provides more flexibility in active traffic management approaching through and beyond the incident scene.

Although VASS will reduce speeds approaching the incident, the ultimate reduced speed immediately upstream of and through the incident area will be higher, thus reducing the length of the rolling queue and impact of the shockwave from reduced speed. The combination of reduced approach speeds and higher speeds through the incident area reduces crash risk.

After the incident is cleared, the time to return to pre-incident flows and speeds is quicker than under existing conditions because of the improved quality of traffic flow in the area of the incident while the lanes are blocked.

iv. How our improvements reduce non-recurring congestion.

The single most important improvement that can be made to reduce non-recurring congestion is to add capacity. As such, the Corman Kokosing Team proposes to implement **30.0 miles** of static-dynamic PTS Use Lanes for the stipulated fixed price allocated for this project, among other improvements. Limits of the PTS Use Lanes are defined below and illustrated in **Figure 4-9**.

- ✓ Inner Loop: From IS-70 to Cromwell Bridge Road (15 miles)
- ✓ Outer Loop: From Cromwell Bridge Road to IS-70 (15 miles)

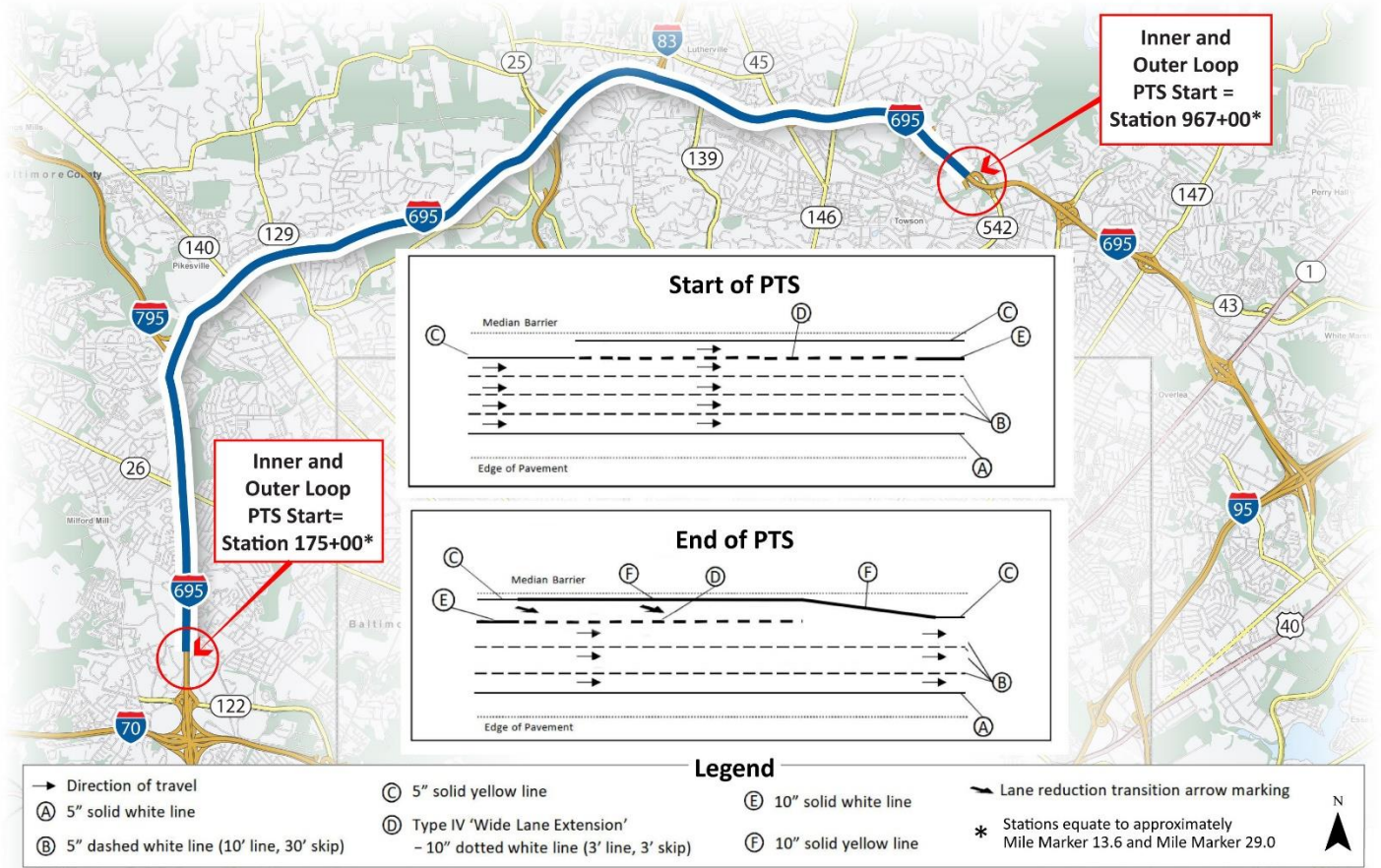

Figure 4-9: Our Limits of PTS Use Lane and the typical striping geometry to start and end the PTS Use Lane

The PTS Use Lanes reduce non-recurring congestion by providing additional capacity, improving traffic flow and reducing traffic density. Non-recurring congestion occurs most frequently from incidents or if a corridor is near its operating capacity, making the corridor vulnerable to fluctuations in traffic volumes. However, reducing non-recurring congestion can be described using two metrics: **Frequency and Intensity**.

Reducing Frequency and Intensity of Non-recurring Congestion: Per FHWA, 25% of all non-recurring congestion is related to a vehicle stopped on or adjacent to the roadway, including both crash and non-crash events. Under normal peak-period conditions with the PTS Use Lane open, the roadway is less likely to be congested, so the risk of non-recurring congestion is reduced. By maximizing the length of PTS Use Lane, we minimize the risk of non-recurring congestion as a result of variations in traffic volumes, weather conditions, and/or crashes, which are the primary causes. Even in non-peak times when the PTS Use Lane is not scheduled to be open, it is available on demand to add capacity when needed, reducing the impact of those events. In one year, along IS-695 there were approximately 2,600 crash events and 1,250 non-crash events that resulted in non-recurring congestion. The capacity added by the PTS Use Lane and the resulting reduction in congestion, reduces both crash and non-crash events. But more than the PTS Use Lane, our ITS design, including AID, CCTV, and VASS monitors changes in traffic flow in the PTS Use and general-purpose lanes, alerting operators early that traffic flow is deteriorating, further preventing non-recurring congestion.

Learning these events in real time and not after the fact is the key to reducing the **frequency** of non-recurring congestion, allowing MDOT SHA time to apply the correct response policy and procedure. VASS automatically adjusts to traffic conditions



to harmonize speeds as needed. This leads to more consistent and harmonized travel speeds during an event, thereby reducing the *intensity* of non-recurring congestion. Through active monitoring by MDOT SHA staff, if speeds begin to reduce along IS-695 within the segment containing the PTS Use Lane, they can activate the LUCSs and DMSs to open the PTS Use Lane and notify motorists. If MDOT SHA chooses to leave the PTS Use Lane closed as speeds reduce, speed harmonization through the VASS reduces the intensity of speed reduction, thus increasing the chance of maintaining reasonable traffic flow and decreasing crash risk.

Another measure indicating the potential frequency of crashes is travel time reliability. When travel time is predictable to motorists, traffic is flowing more smoothly and is more stable. Because traffic flows more smoothly, motorists have less need to brake frequently or brake more severely. In turn, this reduces the chance of congestion related crashes, lowering the frequency and intensity of non-recurring congestion.

Travel Time Reliability: Measuring the travel time reliability provides an indication of how much variation there is in the day to day travel time for motorists. That variation can be measured in terms of standard deviation in travel time. Variations occur with multiple runs of the model. Random seed numbers modify model parameters slightly to deliberately simulate this variation. As a result, some runs provide a better travel time than others, even though the design of the road is unchanged. Based on these travel times for each run, a standard deviation is calculated. The higher the standard deviation, the less reliable the corridor is likely to be in terms of travel time from one day to the next. For example, in the No-build 2040 for the Outer Loop, the standard deviation is 16.5 minutes in the AM peak hour. That means that there is approximately a 68% chance that a motorist’s travel time will be between 219.1 and 252.1 minutes of overall travel time, 16.5 minutes, plus or minus (See Table 4-1).

Our design for the same scenario has a standard deviation of 4.5 minutes, or approximately a 68% chance that a motorist’s travel time will be between 86.0 and 95.0 minutes of overall travel time; obviously, a significantly more reliable commute

Travel Time Reliability				
Inner Loop				
	Total Travel Time (min)		One Standard Deviation for Peak Hour (min)	
	AM	PM	AM	PM
Existing 2018	31.5	42.5	1.4	1.6
No-build 2040	74.3	133.5	10.0	11.1
Proposed 2040	45.9	91.4	4.2	6.4
Outer Loop				
Existing 2018	57.5	36.6	3.3	3.1
No-build 2040	235.6	166.6	16.5	11.2
Proposed 2040	90.5	92.0	4.5	5.1

Table 4-1: Travel Time Reliability

We have demonstrated the benefits of reducing the frequency and intensity of incidents to reduce non-recurring congestion. Below are some additional features of our design that promotes the smooth traffic flow that limits non-recurring congestion.

- ✓ **Enhanced DMS Utilization:** Existing DMSs will be used similar to their current operation, but with connectivity to additional detectors, sensors, and cameras, messages will be more consistently clear and quickly updated as conditions change. They can supplement operation of the AID and VASS devices and can expand the number and type of messages that can be displayed to maximize advanced decision making for motorists. DMSs will provide travel time information, suggest alternate routes, and recommend they reduce speed ahead all based on MDOT SHA's policies and procedures, which improves throughput and travel time, especially under congested conditions.
- ✓ **Lighting Improvements to Improve Visibility at High Crash Zones:** The Corman Kokosing Team has selected specific high crash areas to upgrade the interchange lighting infrastructure and provide enhanced photometrics along the traveled roadway and PTS Use Lanes. These lighting upgrades will pair well with MDOT SHA's implementation of ASTM Type XI sheeting on overhead signs, and high reflectivity pavement markings, providing motorists with ultra-retroreflective messages and lane demarcations, decreasing crash frequencies related to poor visibility and lane drift.
- ✓ **Minimizing Impacts to Existing Conditions:** Our design focuses on construction of the PTS Use Lanes to improve system capacity during peak hours without widening the existing roadway to accommodate an additional full-time travel lane. We also took precautions to not create other impacts as a result of implementing the PTS Use Lane, such as pinch points around bridges, narrow travel lanes, and non-AASHTO compliant outside shoulders that can affect overall IS-695 mobility or safety. By concentrating on these issues, we prevent impacts that slow travel time and reduce throughput. We struck a balance between these competing factors to provide a holistic system that works for motorists, environmental constraints AND the project budget.
- ✓ **Maintaining Functional Lane Widths:** In most cases, the inside shoulder cannot just be restriped and signed to become a PTS Use Lane. Drainage, condition/height of median barrier, width and slope of shoulder, and sight distance are all competing factors in designing the PTS Use Lanes. A slight narrowing of adjacent general-purpose lanes via restriping/ realigning can provide valuable space to accommodate the competing factors created by the PTS Use Lane. However, this may have an impact on traffic flow in the existing general-purpose lanes. The Corman Kokosing Team found creative, innovative solutions to address these factors without resorting to a large reduction in lane widths.



How it Works: Our proposed plan maintains at least 11.5-ft. lanes for the entire corridor. This may seem insignificant; however, maintaining this minimum width makes the reduction nearly unperceivable to the motorist. In fact, from an analysis of the survey data provided by MDOT SHA, there are two locations within the project limits where existing lanes are already less than 11.5-ft. **Our design improves these two existing substandard locations by making all lanes at these locations 11.5-ft minimum.**

The Highway Capacity Manual (HCM) shows expected reductions in Free Flow Speed (FFS) due to reduced lane and shoulder widths. HCM, Exhibit 11-8 shows one can expect a reduction of 1.9 mph using 11-ft. lanes (while the PTS Use Lane is the only 11-ft. lane, conservatively, it would be applied to all lanes through the HCM analysis). Thus, there is little to no impact to travel speeds and throughput, preserving mobility within these lanes while maximizing the length of the PTS Use Lanes.

- ✓ **Maintaining Functional Outside Shoulder Width:** Shoulders are an important roadway feature as they provide a drive recovery area and safe place for disabled vehicles, minimizing traffic flow impacts. As stated above, there are many competing factors when designing the PTS Use Lanes. The Corman Kokosing Team generated a creative and innovative design that balances these factors without sacrificing functionality of the right shoulder, providing an AASHTO-compliant minimum 10-ft. shoulder (or AASHTO compliant minimum 6-ft. shoulder adjacent to some auxiliary lanes). This is vital while the PTS Use Lane is open and the median shoulder area is unavailable for



emergency responders. As with the lane widths, this may seem insignificant, however, maintaining this minimum width preserves the function of these important features for the motorist, providing a refuge for disabled vehicles while preserving mobility within the corridor. These AASHTO-compliant shoulders are also available for emergency vehicles responding to an incident. Thus, there is no impact to travel speeds and throughput in the travel lanes, maximizing the benefit of the PTS Use Lane.

2.09.05 | Operability/Maintainability/Adaptability



MARYLAND DEPARTMENT
OF TRANSPORTATION™

STATE HIGHWAY
ADMINISTRATION



2.09.05 OPERABILITY/MAINTAINABILITY/ADAPTABILITY

i. Discuss how our project allows maintenance to be performed safely while also minimizing impacts to efficient traffic flow on IS-695, including snow removal, mowing, ITS equipment, and ITS communications.

The Corman Kokosing | WSP | MC Dean Design-Build Team (Corman Kokosing Team) identified locations of the Intelligent Transportation System (ITS) equipment that balance system performance, with the ease of maintenance. For example, our design consolidates access components and controllers for ITS equipment into cabinets along the outside shoulder so that maintenance of multiple devices can be completed safely at one location without interrupting motorists. The ITS will support the Part-Time Shoulder (PTS) Use Lanes deployed along IS-695 from IS-70 to Cromwell Bridge Road, with Variable Speed Zones complementing the PTS Use Lane in various locations (See Figure 5-1).

The PTS Use Lanes represent **15.0 miles** of PTS Use Lane on the Inner Loop and **15.0 miles** of PTS Use Lane on the Outer Loop for a total length of **30.0 miles** of PTS Use Lane implemented in the corridor. The following is a general description of each ITS component and the associated maintenance approach:

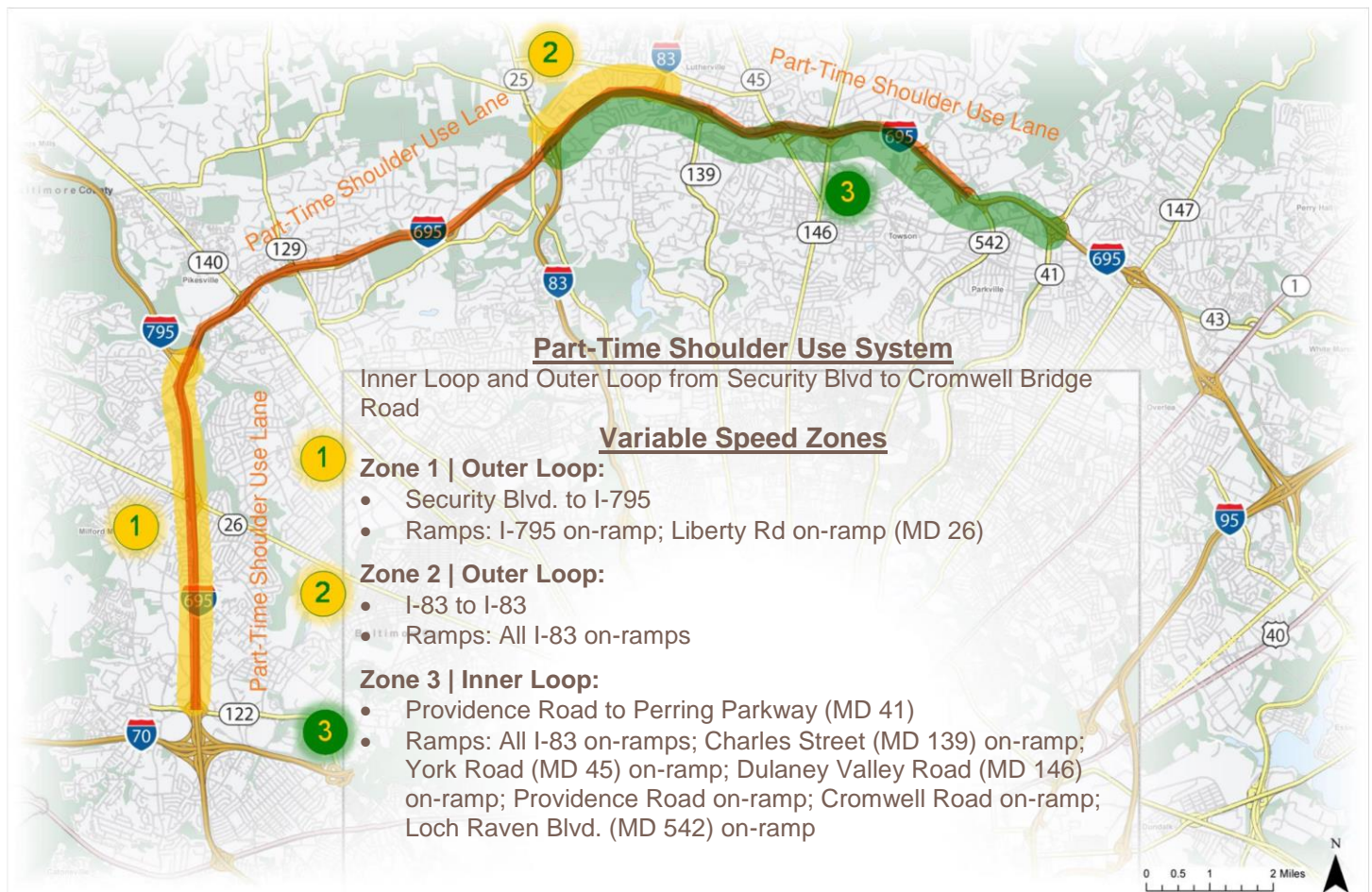
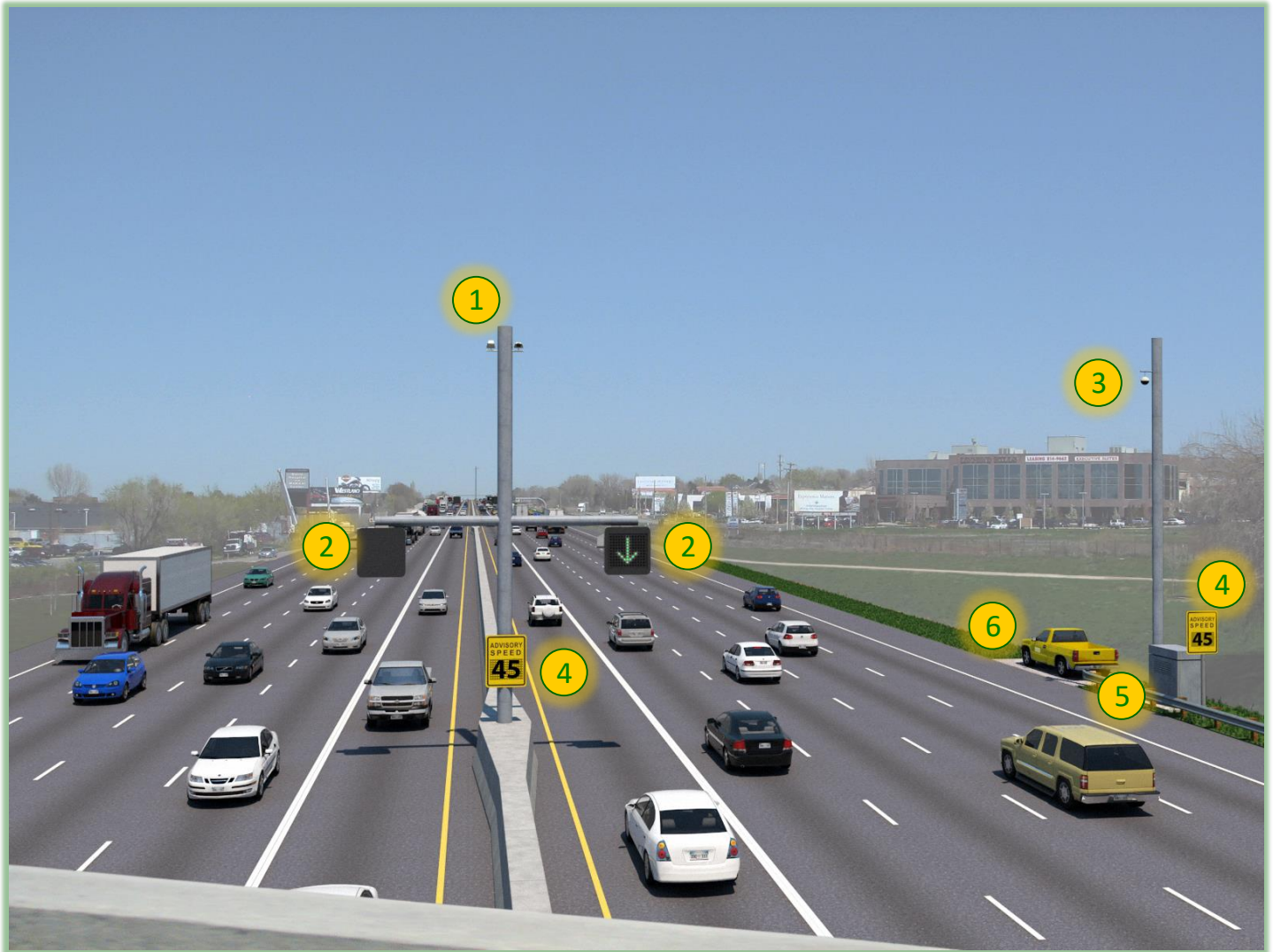

Figure 5-1: Limits of ITS Improvements

ITS Layout Related to Maintenance and Traffic Impact: Our proposed ITS design layout was selected to meet and exceed the RFP requirements for system operability without compromising maintenance of components or future adaptability (See Figure 5-2 for the typical ITS Implementation Layout showing the general locations for major devices). Each ITS device will require a certain level of periodic maintenance as required by the manufacturer; however, it is the location of the



- ① - Automated Incident Detection Camera (AID)
- ② - Lane Use Control Signal (LUCS)
- ③ - CCTV Camera
- ④ - Variable Advisory Speed Sign (VASS)
- ⑤ - ITS Cabinet
- ⑥ - ITS Cabinet maintenance pull-off

Figure 5-2: Typical ITS implementation layout

device and proximity to the travel lanes that will determine the level of effort and safety that can be achieved during normal maintenance procedures.

The Corman Kokosing Team brainstormed through these aspects while at the same time considering impacts to motorists. The following describes how our proposed design accommodates these important aspects:

AID and VDS Cameras are positioned along the roadway median at approximately 640-ft. intervals in areas of full width shoulder (coinciding with PTS Use Lane locations) and where optimal sight distance can be achieved (i.e., avoiding obstructions, including bridges). These wide areas allow CHART personnel to safely perform technical repairs or future system adaptations on the cameras at the support pole with support of the Truck Mounted Attenuator (TMA) per MDOT SHA standards. Maintenance equipment would only be implemented within the closed PTS Use Lane during off-peak hours and would not impact the general-purpose lanes.

Since the system is designed to minimize the need to be in the median, most diagnostic and control system maintenance can be completed at the local ITS cabinets on the outside shoulder eliminating the need to initially troubleshoot these devices from within a closed PTS Use Lane (See further discussion below on the ITS cabinet locations and design approach). Additional details for these detectors are outlined in PTCs #1R2 and 2R2.

Major ITS system control components, including the Advanced Traffic Controllers, LUCS drivers, ethernet switches, as well as access to AID/VDS detectors and CCTV Cameras will be in the ITS cabinets instead of immediately adjacent or attached to the device itself, improving safety and ease of maintenance for MDOT SHA personnel.

CCTV Cameras are positioned outside of the roadway and along the median, adjacent to select ITS cabinets on the outside shoulders, to fill gaps in existing coverage, while meeting the RFP requirement for 100% coverage of the PTS Use Lane. Their locations were pinpointed to provide optimal line-of-sight, to assist with incident response and congestion mitigation. CCTV Cameras will be installed on both dedicated camera poles with lowering devices, and on LUCS poles. 18 additional cameras will be deployed along the corridor, leading to an increase of 129% in camera coverage.

Since these cameras are adjacent to ITS cabinets, protected parking pads are accessible to CHART personnel for safer operation when utilizing the lowering device for CCTV camera maintenance (See further discussion below on the ITS cabinet locations and associated pull-off areas). **Access**

to these CCTV cameras can be made from the ITS cabinet, allowing most diagnostic maintenance to be completed from a safe location.

Lane Use Control Signals (LUCS) have been located to provide clear direction to motorists regarding status of the PTS Use Lane. Sign spacing is between 640-ft. to 2,300-ft., depending on roadway segment geometry. All LUCSs are mounted on independent mast arms that extend into the adjacent general-purpose lane to provide for future roadway shifts per the RFP.

The blister width of the concrete barrier is minimized, allowing for a full width shoulder lane to accommodate the PTS Use Lane with a safety offset to the barrier at each LUCS location. Our strategy behind this is the same as locating the AID and VDS cameras: To protect technicians making repairs or adapting the system with future technologies under the protection of a TMA per MDOT SHA standards.

Similar to the AID and VDS cameras, the system is also designed to minimize the need to be in the median; therefore, most diagnostic and maintenance procedures can be performed at the location ITS cabinet since all controllers modifying the LUCS messages are located in the local ITS cabinets on the outside shoulders. Initial troubleshooting steps will be done from these cabinets, eliminating the need to diagnose any unforeseen device malfunction from within a closed PTS Use Lane (See further discussion below on the ITS cabinet locations and design approach). Additional details for these controllers are outlined in PTC #11.

Variable Advisory Speed Signs are located throughout the corridor; primarily at high volume on-ramps and at the termination points of the PTS Use Lanes. These signs will be mounted to new or existing structures at the standard speed limit regulatory sign height, so bucket trucks may not be needed. TMA will still be required to access them along mainline IS-695 per MDOT SHA standards. Signs on the ramps will be installed on dedicated poles positioned off the shoulder and need bucket trucks

to access. All poles will be behind guardrail or barrier to protect technicians making repairs or when adapting the system to future requirements (Additional details for these signs and controllers are outlined in **PTC #10**). **Controllers for these signs will be mounted in the adjacent ITS cabinets, allowing most diagnostic and maintenance procedures to be completed from a safe location.**

ITS Cabinet Locations Benefit Maintenance and Reduce Traffic Flow Impacts: ITS cabinets will be installed along the outside shoulder and behind guardrail or an equivalent barrier per MDOT SHA clearance requirements. An access drive and parking area will be constructed at each ITS cabinet to accommodate maintenance vehicles and provide a safe exit from the vehicles without 1) impeding traffic, and 2) putting maintenance personnel at risk.

Most ITS devices can be troubleshooted and maintained from the ITS cabinet and will NOT require work within the median. Access and parking pads will be constructed of cellular confinement anchor system, filled with #7 aggregate, and protected by geotextile fabric underneath the aggregate in a manner consistent with other MDOT SHA maintenance facilities.

Generally, the access configuration will be located and designed to minimize the need for additional impact attenuators to accommodate guardrail breaks. If a guardrail break is required, the Corman Kokosing Team will implement guardrail tapers meeting AASHTO and MDOT SHA roadside design requirements (**See Figure 5-3**) to address safety issues associated with access to these parking pads.

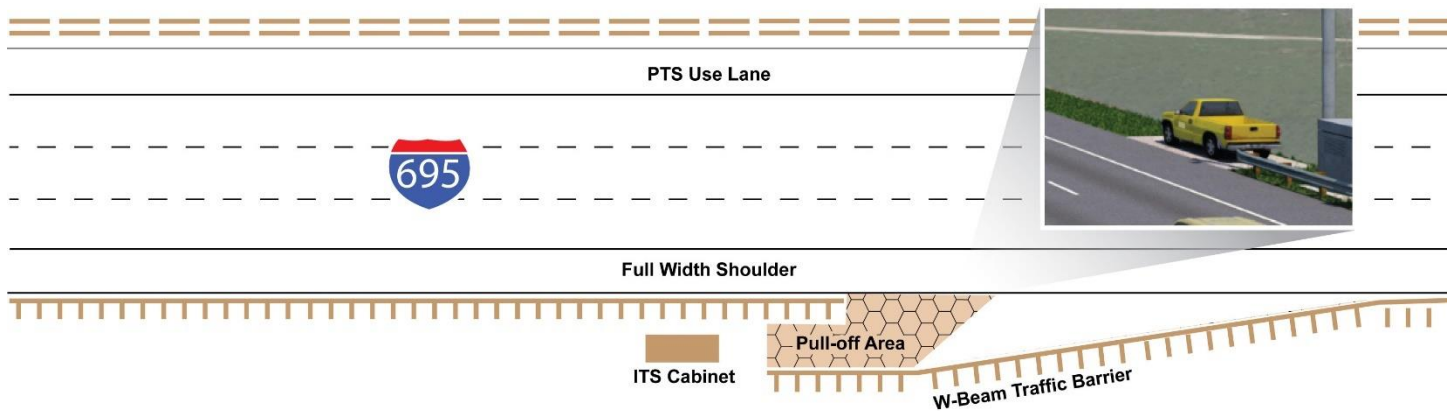

Figure 5-3: Technician parking pad location

In the case where an access cannot be accommodated due to physical constraints (i.e., large roadside ditches, concrete barriers, existing slopes, etc.), the Corman Kokosing Team will implement widened outside shoulders ensuring the ITS cabinet is outside the AASHTO clear zone requirements. Each location will be reviewed and designed with safety and impact to motorists as top priority.

The Corman Kokosing Team has also reduced maintenance and traffic impacts by consolidating several ITS devices (AID/VDS Cameras and LUCSs, etc.) through a single ITS cabinet. The design typically incorporates an average of 8 ITS devices for each ITS cabinet. This translates into less infrastructure needed to be maintained and fewer access maintenance points that interact with the motoring public.

To further enhance safety measures and further reduce motorists impacts, the ITS is designed to minimize work within the median (or reducing the need for shoulder or lane closures) by placing all major ITS controls within ITS cabinets on the outside shoulder. These major ITS control components, including the Advanced Traffic Controllers, LUCS drivers, and ethernet switches, as defined in **PTC #3R1**, are all included within a centralized location instead of immediately adjacent or attached

to the device itself. This allows maintenance on multiple systems at one location while reducing the number of diagnostics points along the system.



BENEFITS: Our approach prioritizes technician safety (behind a barrier and within a protected area) while minimizing motorist impacts by reducing the need for shoulder or lane closures. Control components will be rack or din-rail mounted for quick and easy servicing, and the cabinets will be sized to handle new components as MDOT SHA incorporates future technologies into the system or expands the range of devices.

Select maintenance will only be required at the device location itself. The following is our approach for each device:

- ✓ **Lane Use Control Signals (LUCSs)** are mounted on poles or structures overhanging the shoulder lanes. LED boards will be the only components within the signal housing requiring maintenance. LUCS maintenance is minimal and can be completed under a typical shoulder (closed PTS Use Lane) or mobile closure using a standard bucket truck with a TMA. LUCSs must be serviced during non-peak hours when the PTS Use Lanes are not in use for the safety of the technicians.
- ✓ **AID/VDS Cameras** are pole mounted approximately 40-ft. above the road surface and are accessible by a standard bucket truck. Typical maintenance consists of cleaning and adjusting the cameras which can be performed under typical shoulder (closed PTS Use Lane) or mobile closures. They must be serviced during non-peak hours when the PTS Use Lanes are not in use for the safety of the technicians.
- ✓ **Variable Advisory Speed Signs (VASS) and Controllers** will be positioned and serviced similar to standard Dynamic Message Signs (DMS). As with the other ITS devices, VASS controllers are mounted within the ITS cabinets for safe and efficient maintenance. The LED modules and power supply are the only components mounted within the sign housing. The signs are mounted on structure or pole uprights along the roadway at the same height as typical speed limit signs, and are accessible from a standard bucket truck. Power and multimode fiber cable run from the ITS cabinet housing the controllers to the sign housing. As with the other devices, these must be serviced during non-peak hours when the PTS Use Lanes are not in use for the safety of the technicians.
- ✓ **CCTV Cameras** are mounted in two ways: to lowering devices, attached to CCTV camera poles per standard MDOT SHA practices when above 40-ft; and directly to LUCS poles along the PTS section. The camera's power supply is mounted within an ITS cabinet with the video and data cable connected to the harness either within the camera mounting arm, or the lowering device. When a camera is mounted with a lowering device attached, a standard powered winch assembly will be required to lower the camera for servicing. A bucket truck is not needed when the cameras are above 40-ft, but will be required when maintaining the cameras mounted to LUCS poles.

Major ITS system control components, including the Advanced Traffic Controllers, LUCS drivers, and ethernet switches, as well as access to AID/VDS detectors and CCTV Cameras, will be in the ITS cabinets instead of immediately adjacent or attached to the device itself, improving safety and ease of maintenance for MDOT SHA personnel.

Selected Technology and Service Records: The Corman Kokosing Team selected superior equipment for each subsystem and the control and detection hardware. These components, manufactured by FLIR and Econolite, were developed for strenuous tasks in harsh environments, thus reducing system downtime and emergency maintenance requests. Reliability statistics showcased within the individual PTCs confirm the reduction in failures leading to decreased maintenance requests.

Finally, these manufacturers and regional suppliers offer industry-leading technical and customer support transferrable to the end user. This is not a guarantee for standard traffic component manufacturers. All manufacturer warranties required by the RFP will be provided on these components, and **extended to provide five total years of manufacturer warranty coverage.**

Manufacturer warranties have been extended to five total years

for major ITS components, including the LUCS, Advanced Traffic Controllers, AID/VDS cameras, VASS, ethernet switches, and CCTVs. This will provide MDOT SHA with added security in maintaining up to 56% improvement in travel time across the corridor.

The warranties will apply to all major ITS devices, including the LUCS, Advanced Traffic Controllers, AID/VDS Cameras, VASS, ethernet switches, and CCTVs.

Support Infrastructure Access for Maintenance: In the slim chance that cable or conduit is damaged, or manholes need to be accessed, a shoulder closure (or closed PTS Use Lane) is required for technicians to safely access the troubled area. This is no different than currently accessing other subsurface infrastructure along the interstates.

A TMA is needed to support maintenance when these shoulders (or PTS Use Lane) are closed per MDOT SHA standards. Barrier junction boxes will be placed flush with the face of the barrier, and positioned so that power and communication junction boxes are adjacent to each other. Manholes installed along the right shoulders will be placed flush with the grade and have underdrains so water does not accumulate in the manholes, jeopardizing the cable. Additionally, power and communication manholes

will also be placed adjacent to each other to accommodate junction box access.

Maintenance Impacts due to Snow Removal: Since most components are housed within the ITS cabinets (adjacent the outside shoulder), maintaining a parking pad, as stated earlier in this section, is essential to keeping this system functional during inclement weather. Since the primary snow removal method currently used by MDOT SHA is a salt brine applied to the travel surface, there is less risk from snow plows diverting removed snow off the right shoulder, blocking these driveways. In major snow events, plowed snow may block these cabinet parking pads, therefore, snow removal maintenance personnel will need to remove this compacted snow after main clearing activities cease.

One other item for consideration is placement of the ITS cabinets. The cabinets are generally offset from the edge of shoulder sufficient to reducing the risk of plow driven snow from impacting (or damaging) the cabinet and associated infrastructure.

Maintenance Impacts due to Mowing: Mowing operations are affected when structures, such as cabinets, poles, etc., mounted to foundations protrude above grade. This impacts production and corridor maintenance cost. To reduce mowing maintenance cost throughout the corridor and improve the system's reliability during storm events, **ATC #36R1** was approved to eliminate a separate foundation base-mounted UPS cabinet and mount a bolt-on style *piggy-back* UPS cabinet to the ITS cabinet. This reduces the double impact that would have normally been created at each ITS cabinet location. Additionally, AID/VDS detectors will be placed on new poles within the median or existing sign gantries throughout the corridor. This reduces the number of foundations within the grassy areas adjacent the right shoulders.

Maintaining Traffic Flow when Maintenance Operations are in Progress: Protecting CHART technicians and motorists simultaneously is paramount to the safe and fluid operation of this system. To achieve this goal, maintenance operations should not take place during peak travel times under any circumstances unless absolutely necessary. When emergency maintenance is required to be performed on devices within the PTS lane, LUCS will be modified to show red "X's" so repairs can be made safely. Separately, diagnostic and maintenance activities can be completed at the ITS cabinets with no impact to motorists. Maintenance vehicles are parked outside the shoulder and lane areas behind barriers.

When maintenance operations are needed to impact traffic for any reason, the TMA supported by a full shoulder or PTS Use Lane closure following MDMUTCD standards is required to be deployed. Double lane closures are not required unless there is major damage to the roadway's infrastructure, such as to an overhead sign structure where ITS infrastructure is installed on the upright or gantry.



If closures are required for extended periods of time to maintain the LUCS or AID systems, it is recommended to place advanced variable message boards before the entrance and along the PTS Use Lane corridor advising this malfunction so motorists accustomed to using these lanes do not pull into them due to habit.

Maintaining Drainage Structures along the Median Lanes for PTS Shoulder System Performance: Eliminating water ponding within the median PTS Use Lanes is essential to safely operating this entire system. As such, routine maintenance is required, i.e., annual inspections, debris/trash removal, mowing/reseeding drainage swales, and material replacement as needed. Maintenance activities within the PTS Use Lanes must take place during off-peak hours with constant communication to the Statewide Operations Center (SOC) to ensure the PTS Use Lanes do not activate during this time. Maintenance of traffic signage must be set up, including support from a TMA.

Median drainage system inspections are most critical, requiring visual inspections of inlets, pipes, and corresponding outflows. Support from equipment, including vacuum tank trucks, truck-mounted cranes, and other support vehicles are mobilized during these inspections so recurring visits are not required soon after the inspection takes place within this PTS Use Lane and adjacent offset area. Maintenance activities along the right shoulder should take place during off-peak hours, supported by the TMA, but does not require constant coordination with the SOC. All roadside SWM facilities will be designed and located for ease of maintenance. They will be accessible and if necessary, a break in the roadside traffic barrier will be safely provided.

Structural Inspection: Bridge inspections will continue as they always have and will be unimpeded by our proposed improvements. Inspections generally occur during the hours of the day with the least amount of traffic volume, which is when the PTS Use Lanes will not be needed and operational. Therefore, the inspectors can close the shoulder as necessary, without impact to traffic operations and needing to close an operational PTS Use Lane.

CONCLUSION

The Corman Kokosing Team has designed the ITS components that reduces the time maintenance crews are within the median and PTS Use Lanes by concentrating maintenance services to the ITS cabinets on the outside shoulder. The entire project was designed to ensure ease of maintenance.

ii. Address maintenance personnel/equipment requirements of our improvements after construction is completed, anticipated additional personnel needed to maintain the project, and how we will train existing maintenance forces to operate/maintain the improvements apart of our project.

The ITS components must be maintained for motorists to fully benefit from the investment of this project. An important aspect of maintenance is CHART personnel being properly trained with the understanding of each subsystem so that preventive maintenance can be performed per manufacturer requirements to maximize the system's benefits and service life.

Future Maintenance Process of the Dynamic PTS Use System: To achieve traffic model results long term, the system must be maintained through a maintenance plan. This plan, which will be developed for this project during the design and construction phases, will be provided and reviewed with CHART personnel before handing off the system. It will revolve primarily around the two major components: Advanced Traffic Controller and AID/VDS cameras. LUCS drivers will also need attention to ensure all systems are functioning properly. In order to ensure that these superior devices are cared for during the operation of this system, the **Corman Kokosing Team has extended manufacturer warranties on the major ITS components for five total years**, including warranties on the LUCS, Advanced Traffic Controllers, AID/VDS detectors, VASS, Ethernet switches, and CCTV cameras.

AID/VDS Cameras | Primary: FLIR AID/VDS cameras are the *eyes and ears* of the Dynamic PTS Use System. They primarily monitor the shoulder lane for obstructions and incidents while monitoring the through lanes for performance. Maintaining operational detection cameras is essential to keeping this system operating at its peak performance.

These cameras contain only a few components which require attention: the camera and housing, the power cable's power supply, and the fiber cable. Troubleshooting the status of these cameras is identical to troubleshooting a standard CCTV camera. Verifying power, communication, and camera hardware status are the only variables when attempting to establish a

connection to this device. All of these can be investigated from the cabinet first, potentially obviating the need to close the median shoulder to access the camera onsite. However, if these cannot be addressed from the cabinet, there must be an onsite investigation.

These cameras will have detection zones defined within the configuration module. It is essential that these detection zones remain in the proper location along the roadway for the PTS Use Lane system to receive obstruction and incident alarms. They only shift if the camera is physically rotated. If this occurs, a technician does not need to realign the camera, but redefine the detection zone from within the configuration module. Only if the camera's view angle has shifted substantially (30°+) will it need to be physically rotated. This operation must occur from a bucket truck and requires a shoulder closure.



MAJOR BENEFIT: Most troubleshooting for these superior cameras can occur from the ITS cabinet.

Advanced Traffic Controller | Primary: The Econolite Advanced Traffic Controllers are the main functioning control component of the Dynamic PTS Use Lane system. These controllers operate the function of the LUCS on the timed sequence, while receiving inputs from ActiveITS output, either by the SOC operator or the automated monitoring subsystems. Maintaining operational Advanced Traffic Controllers is required to maintain the *dynamic* operation of this system.

The Advanced Traffic Controllers operate based on timed logic sequences programmed into the configuration. Logic inputs are enabled so that command over-rides can be pushed from ActiveITS. These logic inputs are identical in each controller, so effectively, the software on each controller is identical.

The Advanced Traffic Controllers is connected to a Malfunction Management Unit (MMU) which monitors for any irregularities in the outputs/inputs to the LUCS. When an irregularity is detected, the MMU modifies the LUCS to a safe operation, as defined in **PTC #11**. All troubleshooting is from the ITS cabinet and starts with the MMU. The MMU can be reset in most cases, allowing safe operation to resume. However, should a short be detected on the MMU board, diodes may need to be re-soldered for the safe operation of the PTS Use Lane to continue. This should occur on the bench. Finally, we anticipate the base program of the Advanced Traffic Controllers to be the same for each unit, allowing easier system resets if the configuration corrupts for any reason.

Lane Use Control Signal (LUCS) | Secondary: LUCS are the main display component of the Dynamic PTS Use System. These signals contain two main parts: LUCS drivers and LED display board. The LUCS drivers are mounted within the ITS cabinet, while the display board is mounted within the housing installed in the mast arm overhanging the managed PTS Use Lane.

Maintaining operational LUCS is required to safely display the status of the Dynamic PTS Use Lane system. The LUCS operate nearly identical to LED Blank-Out signs, with added functionality of return signals for confirmation and errors. The main functional component of the sign is the LUCS drivers, which are mounted within the ITS cabinets. These rack-mounted drivers receive outputs from the controller to display a message on the LED display board. The status of the LUCS driver is displayed on the outside of the driver, much like a card in a traffic signal controller. Additionally, the MMU displays error signals output by the LED display board to identify if the sign is functioning properly. If an error is encountered, the technician should review the LUCS driver first.

To troubleshoot the driver, output of the controller output can be overridden to change the displayed message. The LED display board is an integrated board which receives the signals from the LUCS drivers to display the Yellow "X", Red "X", or Green "↓". If the LUCS driver is operational, but the message is not properly displayed, a replacement LED display board needs to be installed.



Preventative Maintenance of this system revolves primarily around proper component operation within the cabinets. Attention is needed every 12 months to clean, monitor, inspect, and replace worn components. Separate cabinets are not being deployed for the separate subsystems, so a decreased amount of locations is required to be maintained. Preventative maintenance should take a two-technician crew approximately four hours and can be performed without any type of shoulder or lane closure. Since approximately 33 cabinets are anticipated to be deployed as part of this project, a total duration every 12 months is expected to be 17 days.

Anticipated Personnel: As a part of this project, over 100 devices are anticipated to be deployed for a fully-functional system. While that sounds like a large number of devices, the Corman Kokosing Team does not anticipate a large increase in CHART maintenance activities. The reason for this is that two main components (AID/VDS cameras and LUCS), are nearly identical to components deployed at traffic signal intersections throughout Maryland. The AID/VDS cameras are nearly identical to the standard vehicle detection cameras deployed at intersections, and the LUCS are nearly identical to LED Blank-Out Signs installed around the state. These traffic signal components are maintained by the Office of Traffic and Safety, so additional resources can be shared when a failure is experienced by these similar components.

Should MDOT SHA want a maintenance team dedicated to this corridor, maintenance activities can be completed with a three-person crew and standard bucket truck.

Training: A thorough training program will be developed/managed by the Corman Kokosing Team comprised of individual sessions held by the manufacturer of deployed components and the ATM developer, Southwest Research Institute:

- ✓ **ATM Training:** Southwest Research Institute will hold two days of onsite training, specializing in operator and administrator level functions and activities. Training materials, including operator and administrator manuals, will be provided for this *hands-on* experience.
- ✓ **AID/VDS Detector Training:** Local support personnel will hold one day of onsite training, specializing in detector set up, maintenance, configuration and troubleshooting. This is intended to simulate handling the detectors, without being in a bucket truck or roadside. Operations manuals will be provided for future reference by CHART technicians.
- ✓ **VASS Signs:** Manufacturer personnel will hold as-needed onsite training, specializing in DMS controller configurations to allow the ATM to control the variable speed message posted, and maintenance of the LED components. This is intended to simulate handling the controller components and LED panels without being in a bucket truck or roadside. Operations manuals will be provided for future reference by CHART technicians.
- ✓ **LUCS:** Local support personnel will hold as-needed onsite training, specializing in maintaining the drivers and LUCS. This is intended to simulate handling the sign components or LED drivers, without being in a bucket truck or roadside. Operations manuals will be provided for future reference by CHART technicians.
- ✓ **Advanced Traffic Controllers:** Local support personnel will hold as-needed onsite training, specializing in maintaining the configuration required for the ATM to control operation of the LUCS. This is intended to simulate programming the controllers, without being roadside. Operations manuals will be provided for future reference by CHART technicians.

This comprehensive training program is aimed at building a strong foundation of component understanding to ensure the long-term operation of this system.

iii. Discuss how our improvements are adaptable to future transportation technological advancements.

The 2040 VISSM model is based on parameters defined in 2019 (using 2018 data) and does not take into consideration any future changes which cannot be reasonably expected. With that being said, ActiveITS can expand active traffic management applications with several approaches, including expanding the existing deployment, beyond the limits discussed, or integration of future technologies to add reliability and responsiveness to the system.

Scalability of the Dynamic PTS Use System: All of the components and subsystems will integrate into the deployed ATM, ActiveITS. Since we anticipate future expansion of the system, the ATM is being designed to be scaled upward in size and



functionality. The database will have up to 65-75% capacity for additional AID/VDS cameras and LUCS with the only added cost being additional AID camera modules from FLIR and licenses from SwRI. Additionally, over 30 unused modules will be installed with ActiveITS should MDOT SHA deploy separate technologies in the future.

Integration of Additional Technologies – Speed Harmonization: As part of this deployment, the Corman Kokosing Team will deploy VASS along the corridor at several locations highlighted above and integrated within the ActiveITS module. This additional technology uses speed harmonization to decrease recurring/non-recurring traffic congestion. The algorithm developed contains multiple thresholds and decremental changes in the advisory speed, and is solely based on traffic flow data produced by the Vehicle Detection System (VDS) and received by ActiveITS. This system allows the VDS data source to be modified, should collection methods change over the system’s lifetime, prolonging the effects of the VASS. The posted speed limit signs will NOT be removed as part of this project, and the legal speed limit will remain at 55 MPH. The advisory speeds will be adaptable, but posted speeds will not be per Maryland State law.

Integration of Future Technologies: As the world of ITS evolves, the ATM deployed along IS-695 can also expand. Connected technologies, whether vehicular or pedestrian, are largely untapped data sources to integrate into these managed systems. Reliability may not be as high as dedicated detectors, but variance in the data reported improved tremendously since initially deployed. Data sources, such as Inrix and Waze, offer MDOT SHA alternatives to owned and managed detectors, which can be easily integrated to the included module. This change in data source will allow current and future operational procedures to be maintained or implemented as well. ***It is not the intent of the Corman Kokosing Team to integrate with any external data source as a part of this project.***

Expansion of ITS protocols: The Corman Kokosing Team selected each ITS component from the perspective of meeting MDOT SHA’s immediate needs as per the RFP, with a system that can adapt to future operational and technological advancements. For example, PTS Use Lanes will be opened and closed based on time of day and current SOC operational procedures. AID/VDS cameras will provide information to operators who manually override the time of day commands based on standard operating procedures for non-typical events (i.e., traffic incidents, lane blockages, etc.) as defined by the SOC. The ITS components and subsystem functions proposed can be controlled through a fully automated ATM.

As automated connected technologies become commonplace in vehicles or consumer electronics, the demand for automated system controls will increase. Our system will function effectively using current operational procedures, and given anticipated changes in future technologies. See the previous section labeled *Integration of Future Technologies* for additional information.

The Corman Kokosing Team’s ITS design can accommodate future monitoring enhancements with little to no modifications. The FLIR Thermibot2 cameras are used for the AID/VDS cameras which can perform advanced data analytics providing incident detection solutions beyond what is currently being used by the SOC. In addition to detecting traffic congestion and speed drops, the Thermibot2 can detect issues, such as disabled vehicles, pedestrians, and fallen objects. As MDOT SHA incorporates future technologies into command center operations, information provided by the Thermibot2 can be used to quickly dispatch responders, whether they be emergency services, tow trucks, or maintenance crews improving the operability of the PTS Use Lane.

Lighting Improvements to Prolong System Operation and Improve High Crash Zones: The Corman Kokosing Team has selected high crash areas to upgrade the interchange lighting infrastructure and provide enhanced photometrics along the traveled roadway and PTS Use Lanes. These lighting upgrades will pair well with MDOT SHA’s implementation of ASTM Type XI sheeting on overhead signs, and high reflectivity pavement markings, providing motorists with ultra-retroreflective messages and lane demarcations, decreasing crash frequencies related to poor visibility and lane drift.