

2023/2024

# Maryland State Highway Administration Salt Management Plan



MARYLAND DEPARTMENT  
OF TRANSPORTATION™

STATE HIGHWAY  
ADMINISTRATION

Table of Contents

Table of Contents.....i&ii

1 Preface ..... 3

2 Introduction ..... 4

    2.1 Public Safety..... 4

    2.2 Environmental Protection..... 4

    2.3 Efficient Transportation System ..... 4

    2.4 Fiscal Responsibility ..... 4

    2.5 Continual Improvement..... 4

    2.6 Local Development of Salt Management Plans ..... 4

3 Safety and Mobility ..... 5

    3.1 Passable roadway expectations..... 5

    3.2 Class 1: Interstate highways and major US routes that connect to adjacent states ..... 5

    3.3 Class 2: High volume highways (high average daily traffic (ADT))..... 5

    3.4 Class 3: Highways with moderate ADT ..... 6

    3.5 Class 4: Highways with low ADT ..... 6

    3.6 Exceptions..... 6

4 Establishing Goals to Reduce the Negative Impacts of Salt..... 7

5 Equipment and Materials ..... 8

    5.1 Types of Winter Materials ..... 8

    5.2 Material Storage and Handling ..... 9

    5.3 Snow and Ice Control Equipment ..... 9

        5.3.1 SHA Equipment ..... 9

        5.3.2 Hired Equipment Contract for Snow Removal Services..... 11

6 Training Initiatives..... 12

7 Winter Storm Management..... 13

    7.1 Weather and Pavement Condition Forecast ..... 13

    7.2 Pre-Storm Planning ..... 14

    7.3 Anti-icing Operations ..... 14

    7.4 Winter Storm Operations ..... 15

    7.5 Severe Winter Storms..... 15

    7.6 Stockpiling and Disposal of Removed Snow ..... 17

    7.7 Operations in Sensitive Areas ..... 17

    7.8 Automatic Vehicle Location (AVL) ..... 17

8	Post Storm Operations.....	19
8.1	Equipment Cleaning and Maintenance .....	19
8.2	Material Cleanup at Storage Facilities .....	19
8.3	Operations Review for Continual Improvement.....	19
8.4	Post Storm Data Analysis .....	19
9	Spill Prevention and Control Plan for Winter Operations .....	21
9.1	Salt Spill Prevention .....	21
9.2	Brine and Magnesium Chloride Mixing and Storage Tanks .....	21
10	Recordkeeping and Annual Reports .....	22
11	Annual Winter Wrap-Up Meeting.....	23
12	Public Education and Outreach .....	24
13	Testing and Evaluation of New Materials, Equipment, and Strategies for Continual Improvement .....	25
14	Summary .....	26
15	Appendix A: Hired Equipment Presentation.....	27
16	Appendix B: Snow College Presentation.....	90
17	Appendix C: OOM Winter Town Meeting.....	203

# 1 Preface

In 2010, the Maryland State Legislature passed two (2) bills, House Bill 0903, and Senate Bill 0775, which required the establishment of a Statewide Salt Management Plan. The legislature tasked The Maryland State Highway Administration (SHA), in conjunction with the Maryland Department of the Environment (MDE), to develop a road salt management best practices guidance document by October 1, 2011, for use by the state and use/or reference by local jurisdictions. The purpose of this document is to provide guidance and direction for the optimized use of road salt (primarily sodium chloride) and liquid deicers (primarily salt brine) during winter operations, to lessen the adverse impacts of salt in the state. These best practices for Salt Management discuss how to minimize road salt and liquid deicer use from its delivery, storage, handling at salt storage locations, placement on highways during winter storms, and post-storm cleanup operations. The following best practices should be a starting point in an agency's plan to minimize the negative impacts of salt and liquid deicers on highway assets and the existing environments of Maryland.

The primary objective and goal of this Statewide Salt Management Plan is to provide a framework for highway agencies to deliver safe, efficient roadway systems during winter storms in a cost effective, environmentally sound, and sustainable manner. The secondary objective and goal of this plan is to consolidate SHA's current practices and manuals into a single comprehensive guidance document.



## 2 Introduction

To be effective, a Salt Management Plan (SMP) should contain the principles and goals of a jurisdiction that deliver an enhanced Level of Service (LOS) to the traveling public while consistently meeting the agency's mission on environmental stewardship. The common goals for all jurisdictions include:

### 2.1 Public Safety

Effective winter storm maintenance has a direct impact on the safety of roadway users and on the personnel performing the maintenance. In the development of this plan, safety will be the primary goal.

### 2.2 Environmental Protection

Since the use of salt in high concentrations can have a negative impact on highway structures as well as roadside soil, plants and receiving waters, the development of the Best Management Practices (BMPs) contained in this plan will consider practices that promote careful handling and application of winter materials such as rock salt and brine solutions, minimize the total usage of those materials, and thereby minimize and reduce the negative impacts of winter operations.

### 2.3 Efficient Transportation System

Efficient transportation systems are essential in maintaining the mobility necessary for economic stability and in providing the quality of life expected by a jurisdiction's constituency. SMP development should factor in these requirements.

### 2.4 Fiscal Responsibility

State, county and local jurisdictions are bound by budgets determined by their governing bodies. The SMP for these jurisdictions must be within their financial capabilities.

### 2.5 Continual Improvement

To progress in the reduction of salt usage and negative impacts, jurisdictions need to consistently seek to improve current practices. Each jurisdiction should assess goals, technologies, practices, materials, and equipment on a recurring basis to determine if any changes can affect salt usage or reduce negative impacts. Since these changes may have a fiscal impact, there must be recognition that many changes may be incremental.

### 2.6 Local Development of Salt Management Plans

Because of the variances in state, county and local transportation agency resources and mission objectives, SMPs for said jurisdictions should be locally developed. The plans should define the key elements of an environmental management. Commitment to the plan should include accountability, goals, measurement of progress, communication, reporting, and periodic review. These aspects will ensure that local SMPs are living documents that allow for continual improvement.

### 3 Safety and Mobility

Agencies, such as SHA, are keenly aware of their goal to provide safety and mobility during winter storms in a cost-effective manner while minimizing environmental impacts to the maximum extent practicable.

In the reality of winter storms, the ideal outcomes for this goal are difficult to achieve and at times, conflict with one another. The principal driving force that often decides the hierarchy in this potential conflict is the defined LOS an agency is obligated to provide its customers.

However, LOS may not be the most appropriate and practical level of measurement during winter operations. During a winter storm, agencies should consider defining safety and mobility in terms of a “passable roadway”, considering the limitations imposed by weather conditions, resource availability and environmental concerns.

SHA defines “passable roadway” as a roadway surface that is free from snow drifts, snow ridges, and as much ice and snow as is practical that can be traveled safely at a “reasonable speed for the conditions”. A passable roadway should not be confused with "bare pavement," which is essentially free of all ice, snow, and any moisture. It should be assumed that a bare pavement condition may not exist until the weather conditions improve, and plowing can remove the full amount of snow and slush from the pavement.

"Reasonable speed" should be defined as a speed at which a vehicle can travel without losing traction. During and immediately after a winter storm event, a reasonable speed is assumed to be lower than the posted speed limit. Motorists should expect some inconvenience and modify their driving practices to suit road conditions.

#### 3.1 Passable roadway expectations

It is considered inappropriate to attempt to melt snow as fast as it hits the ground or to keep the highway wet to eliminate any accumulation. Ideally, the proper combination of plowing with the appropriate amount of salt or brine should be used to prevent the bond from forming. If snowpack should occur, agencies should strive for “passable roadway” conditions and eventually “bare pavement” as soon as practical after the winter storm event has ended.

#### 3.2 Class 1: Interstate highways and major US routes that connect to adjacent states

For a winter event that is forecast to start as snow or sleet, highways in this category should be anti-iced with salt brine between two hours and two days prior to the anticipated start of the event. This will provide a thin layer of salt to adhere to the pavement and prevent the frozen precipitation from bonding to the surface. During the active winter storm event, these highways should be maintained in “passable roadway” condition on all lanes and ramps. Plowing is the primary tool for snow removal, with road salt and/or salt brine as a re-application, to continue preventing the bond of ice or snow to the pavement.

#### 3.3 Class 2: High volume highways (high average daily traffic (ADT))

For a winter event that is forecast to start as snow or sleet, highways in this category should be anti-iced with salt brine prior to the anticipated start of the event. This will prevent the frozen precipitation from bonding to the surface. Highways in this category typically have high traffic volumes that make it necessary to focus on more than just the driving lanes during the winter storm event. On these highways “passable roadway” conditions should be maintained on the driving lanes, turn lanes and acceleration/ deceleration lanes during the winter storm event. Plowing is the priority for snow removal.

Agencies should strive to keep the snow from packing on the driving lanes, turn lanes and acceleration/deceleration lanes during the winter storm event. Only enough road salt or salt brine should be re-applied to keep the precipitation from bonding to the roadway surface.

### 3.4 Class 3: Highways with moderate ADT

On these highways, agencies should strive for “passable roadway” conditions on the driving lanes, turn lanes and acceleration/deceleration lanes during the winter storm event. Plowing is the first priority for snow removal. Agencies should apply only enough road salt and/or salt brine to prevent bonding during the event.

### 3.5 Class 4: Highways with low ADT

On these highways, agencies should strive for “passable roadway” conditions on the driving lanes, during the winter storm event. Plowing is the priority for snow removal. The agency should strive to keep the snow from packing on the driving lanes during the event, only applying enough road salt and/or salt brine to keep the precipitation from bonding to the roadway surface.

The classes generally correspond to the roadway functional classifications as defined by the Federal Highway Administration (FHWA).

### 3.6 Exceptions

Exceptions to this guideline will occur when a winter storm event is followed by subsequent storms that happen at a frequency where it is not possible to obtain passable roadway conditions and bare pavement between events. The severity of an event, roadway temperatures, geography, time of day, day of the week, and availability of re-deployable resources will dictate how soon passable roadway conditions and bare pavement can be obtained.

Passable roadways during winter storm events, as identified above allow emergency responders to provide adequate response times and transport to emergency facilities.

## 4 Establishing Goals to Reduce the Negative Impacts of Salt and Liquid Deicers

The tool that most winter maintenance agencies use to provide safe, passable roadways is the tried-and-true combination of plowing and salting. While the best practices of this plan are readily understood as tools for managing the impacts of winter materials on budgets, highway managers should also be aware of the costs and negative consequences of salt on highway infrastructure and environments beyond the right of way.

Salt and all winter materials have positive benefits as well as potentially negative impacts. In addition to the costs of the deicing materials and their application, the use of these materials can be economically damaging to SHA because they deteriorate concrete and corrode aluminum and steel. Of no less importance, these materials may also cause costly damage to trees, grass, and other plants, while having detrimental impacts to water quality and aquatic organisms.

Perhaps worst of all from the perspective of the highway maintenance manager, the heavy and repeated use of salt and other winter materials can permanently damage the structure of landscape soils, reduce the ability of soils to physically support traffic loads or resist rutting, and can destroy the ability of the soil to sustain plant growth. All these consequences can lead to large areas of bare soil, embankment erosion, and various types of structural failures.

As the use of salt and other winter materials increase in any area, the severity, economic costs, and environmental impacts of salt also tend to increase. The purpose of the SMP is ultimately to reduce the likelihood, severity and costs of winter materials and their consequences. To that end, some understanding of the specific problems that may be caused by winter materials are useful to understand.

Rock salt is predominantly sodium chloride. In addition to damaging structures, sodium causes physical deterioration of soils, makes soil more alkaline and removes nutrients, and after years of sufficiently heavy use can cause such extensive damage that complete removal and restoration of the soil is the only practical solution. In addition to damage from sodium, the chloride content of rock salt is cumulatively damaging to soils, plants, and water quality.

Although soils can absorb and safely ‘excrete’ relatively large amounts of sodium and chloride over time due to the cleansing action of rainfall, the heavy and repeated application of salt is eventually unsustainable and leads to irreversible damage. Likewise, heavy and repeated use of brine solutions which may contain sodium chloride as well as magnesium chloride pose similar problems and are eventually damaging to both plants and soils when applied in excess.

In the end, this plan is intended to serve the interests of citizens and the business community by reducing the cost of applying winter materials as well as the cumulative costs and environmental impacts of salt resource overutilization.

There is an adage “that which gets measured, gets done” and best practices for salt management are no exception. Winter operations managers must track salt usage along with other related snow and ice control efforts, and they should also measure the severity of winter weather to determine how severity correlates to salt use and salt damage to highway structures and landscaping.

Setting annual quantity goals for salt reduction is not always practical due to the dynamic nature of winter storms that vary in number, intensity, geography, and other factors. Thus, measurements should be used to recognize and respond to trends and usage patterns, rather than to simply develop annual reduction goals. However, by analyzing trends and understanding the negative impacts of winter materials, it is possible to develop and implement a responsible plan with long-term goals that reduce the likelihood of damage while maintaining acceptable safety and mobility for highway users.

## 5 Equipment and Materials

Winter operations require specific equipment and materials to maintain safe, passable roads. The equipment must be properly serviced, calibrated and/or repaired prior to the beginning of the season. Materials require proper storage, handling, and distribution across the roadway system.

### 5.1 Types of Winter Materials

Salt is the primary snow and ice control material used by SHA and by many agencies throughout the country. It is used because it is effective for winter storms in Maryland, inexpensive, easily stored, and readily available. Granular road salt is used primarily during storms when precipitation has already begun to fall. Over the past few decades, research into other materials has been conducted, but none have been able to replace salt in benefit/cost effectiveness and reliability. While it will continue to be the primary material for fighting winter storms, agencies should continue to look for ways to minimize its use. That is the focus of this SMP.

The second most used material by SHA and other agencies across the country is salt brine (liquid sodium chloride). Salt brine is used by SHA and other agencies primarily in anti-icing operations prior to storms, but in recent years has also been used for Direct Liquid Applications (DLA) during winter events. It is sprayed on highways by applying a critically measured solution two hours to two days prior to the onset of frozen precipitation to prevent snow and ice from bonding to pavement. It is also used to pre-wet granular salt as salt is spread on highways in deicing operations to reduce bounce and scatter. Salt brine is used when snow or ice has already accumulated on the surface of the highway. Deicing involves plowing and spreading salt to remove the frozen precipitation from surfaces. Anti-icing and deicing will be explained in greater detail later in this document.

Salt brine has several attributes that explain its rising usage. First, it is easily manufactured using a brine maker. Dry salt is dissolved in fresh water and brought to a concentration of 23.3% sodium chloride, this brine is then pumped to storage tanks where it is available for application on roads. Whereas salt begins to lose its effectiveness at 20 degrees, brine has a freeze point of -6 degrees, and will work when road salt is ineffective. SHA, for example, has 15 automated brine makers strategically placed across the state. Should equipment budgets remain fluid, SHA anticipates the installation of additional makers to re-distribute production in a more efficient manner.

SHA and other highway agencies also use limited amounts of liquid magnesium chloride (mag). Mag has a freeze point of -26 degrees and can work in winter storms with very cold pavement temperatures. Mag is used only to pre-wet salt prior to application. SHA, for example, does not spray mag directly on highways prior to storms. Although mag works well once precipitation begins to fall, SHA and other highway agencies across the country have found that mag can make highway surfaces slippery, under certain atmospheric conditions, during the hours leading up to the start of the storm.

Agencies, including SHA, use abrasives (sand or crushed stone) in their winter operations although these materials have no snow melting characteristics. Abrasives are not normally used when a very high LOS is required. In addition, abrasives can clog drainage structures and contribute to air pollution. Agencies may consider using a mix of salt and abrasives to increase traction for motorists during storms with freezing rain or with very cold pavement temperatures when salt becomes less effective. SHA uses these mixes primarily in Western Maryland due to the steep topography and strict environmental restrictions across the rest of Maryland. Abrasives should be used sparingly as they are maintenance intensive, requiring mechanical removal via street sweeping or berm removal and may also require storm drain or ditch cleaning after the winter season.

Agencies should continue to explore and research innovative materials which can produce results equal to or better than sodium chloride.

## 5.2 Material Storage and Handling

Agencies should store salt in salt barns, salt domes, or other permanent structures whenever possible. SHA for example, stores all its material in domes or barns. The structures should be well maintained. Potential problems should be identified during routine operations or through a periodic inspection program. Maintenance should be performed on structures during the off-season. Aging structures that have repeated high repair costs should be replaced when funding is available. Preventive measures, including only loading a salt structure to design capacity, are the most effective method in maintaining these structures. Proper loading of any structure, dome or barn, is crucial to maintaining its integrity and the safety of agency/contractor employees.

Properly maintained structures, along with good housekeeping practices, allow agencies to keep salt in proper structures, minimizing negative impacts. SHA uses a variety of methods to prevent salt from spilling out of structures. Maintenance facilities place straw bales, aggregates, or wooden gates at the structures' entrance. Agencies should gather salt spilled near salt structures during loading and unloading operations. Unused material should also be returned to the salt structure.

When fixed structures prove to be cost-prohibitive or not feasible, salt should be stored on impervious surfaces, such as asphalt pads, to prevent groundwater contamination. If material is not stored in fixed structures, it must be covered with a secured tarp.

Agency procedures should be in place for capturing salt spilled on pavement during the loading or unloading of the material. SHA for example, maintains regulatory required Stormwater Pollution Prevention Plans (SWPPP) for all primary facilities, and has developed SWPPPs for satellite salt storage facilities as a BMP. The SWPPPs outline pollution prevention measures for salt storage and handling. Large salt spills should be addressed using equipment such as a front-end loader, while small amounts can be addressed with a shovel and broom. In either case, the material should be returned to the salt structure as soon as possible. To ensure salt is properly contained and not exposed to stormwater, routine inspections are conducted by facility personnel and environmental professionals.

Liquid deicing materials, such as salt brine or magnesium chloride, should be stored in well maintained and labeled storage tanks. Due to the corrosive nature of these substances, routine maintenance must be performed on the storage tank fittings, valves, and pumps to keep them in good working order.

Additionally, the liquid storage tank itself should be checked for bulging, expansion, leaking or dripping and any findings should be corrected as soon as possible. SHA also ensures that new brine tanks installed during a major facility renovation are constructed with secondary containment to hold, at minimum, the volume of the largest tank. All secondary containment is inspected, repaired, and maintained, along with any surrounding landscape damages that may have resulted from a breach in the system.

## 5.3 Snow and Ice Control Equipment

SHA purchases a variety of equipment and assigns it across the state to meet the needs of each maintenance facility.

### 5.3.1 SHA Equipment

Agencies should procure and employ the most effective snow removal equipment possible. Dump trucks should be equipped with well-maintained front plows that can mechanically remove as much snow as possible from highways. When appropriate, agencies should use side or "wing" plows to increase the amount of snow, in area, that can be mechanically removed from highways with each pass.

SHA also uses a hybrid rubber/ceramic plow blade that is designed for high performance and efficiency. These hybrid blades provide higher surface area

contact with the road, which enhances the clearing ability while significantly reducing the wear on line striping and pavement markings. SHA has expanded the use of these blades throughout the state, and other agencies should look to do the same. Effective mechanical removal of snow is the most environmentally sensitive method of snow removal and results in less salt needed to maintain a road in a safe, passable condition.

Dump trucks should also be equipped with well-maintained salt spreaders and spinners that can apply the required amount of salt on roads in an effective pattern that minimizes material waste. Agencies should consider and employ, whenever possible, electronically controlled salt spreading equipment. This equipment can be remotely controlled to a specific application rate that will prevent operators from using more salt than necessary.

Agencies should calibrate all salt spreading equipment, regardless of its type, prior to the start of a winter season and check it for accuracy periodically throughout the season. This is a critical aspect of effective salt management. Additionally, technological advances now allow for this equipment to capture location, as well as salt application rates and usage, which is specifically useful for tracking purposes in environmentally sensitive areas.

Agencies should use other specialty equipment for removal of snow from highways, when appropriate. Snow blowers are effective in removing a heavy buildup of snow, particularly from highway shoulders. Front end loaders are effective in removing a heavy buildup of snow from sections of roads where plows are not effective, such as narrow residential streets with parking on both sides and gore areas. In this case the snow needs to be placed into dump trucks and hauled away. Motor graders may be needed to mechanically remove snow or ice that has “packed” on highways. Effective use of these specialized pieces of equipment lessens the need for salt to return a roadway to a passable condition.

SHA maintains a fleet of dump trucks, the majority of which are single axle units capable of carrying 5 to 6 tons of salt. The remainder of its dump truck fleet consists of tandem, tri-axle, or quad-axle trucks capable of carrying 10 to 15 tons of salt or slide in 2600-gallon tanks for anti-icing or DLA snow routes. The dump trucks are equipped with well-maintained plows, and electronically controlled spreaders that can apply the required amount of salt on roads in an effective pattern that limits material waste. The equipment is calibrated for accuracy prior to the winter season. SHA also has a limited fleet of specialty equipment including snow blowers, front end loaders, and motor graders.

As with winter materials, agencies should continue to explore and research innovative equipment for the mechanical removal of snow and ice from the roadways. For example, SHA has researched, piloted, and procured “tow plows” for assignment to various facilities. These tow plows, in conjunction with a front plow, can perform snow and ice removal comparable to multiple trucks with only front plow and can cover an additional lane beyond a truck with front and wing plow. Tow plows cut down on carbon emissions as well, by eliminating the extra exhaust fumes and possible roadway contaminations from leaks or spills. SHA has also retrofitted some of its truck fleet with wing plows on both sides of the vehicle, allowing coverage of additional lanes.

SHA also has procured 34 loader scales. These scales, installed on front end loaders, can accurately weigh salt being loaded into a truck to track salt usage by the truck when running its routes. This is helpful when it is necessary to address roadways in environmentally sensitive areas, such as watersheds, residential wells, and public reservoirs.

SHA replaced its 15 antiquated salt brine makers with automated units that can produce, with the correct water supply and solar salt, up to 9,000 gallons of brine per hour. They are strategically located to fill and replenish the 77 tank farms around the state. Each unit can be remotely controlled from a smart device if cell service is available in the area. This will help ease the burden of brine tank replenishment by quadrupling the output of our current units while producing a perfectly blended solution.

### 5.3.2 Hired Equipment Contract for Snow Removal Services

Agencies should consider hiring supplemental contract equipment to support their own forces if needed, to maintain prescribed LOS. Hired equipment must be equipped with well-maintained plows and spreaders to assure effective and efficient snow removal and salting operations. Poorly equipped and maintained contract equipment can lead to excessive salt use. Agencies should provide training materials to hired contract equipment operators in all facets of plowing and salting operations. Poorly trained contracted operators can use excessive amounts of salt. SHA provides required online training for its hired equipment operators prior to the winter season.

Agencies need to train frontline supervisors to ensure effective management of contractors and their equipment. This ensures that contract operators are following an agency's policies and procedures, particularly in salt usage.

For example: spreader systems on contracted dump trucks should be calibrated prior to winter. Tests should be performed on each unit to ensure that the amount of salt physically spread on a highway correlates to a setting on the control knobs in the truck's cab. It is critical that contract trucks are calibrated, and its operators are closely monitored by agency personnel to avoid improper salting. SHA ensures that contractors' trucks are calibrated and can pass a stringent quality control inspection prior to entering a contract.



## 6 Training Initiatives

Training is a critical component of salt management and a BMP in winter operations. Agencies should provide training in salt management to maintenance managers and frontline forces on a regular basis. Many agencies, including SHA, have a “Snow College” or “Snow Academy” to accomplish this initiative. The focus of the training should be on BMPs that stress the importance of using the least amount of material as possible to provide safe, passable roadways for motorists. SHA, for example, provides “Snow College” (Appendix B) every year for all new employees and 20% of maintenance forces. In this manner, SHA ensures that all maintenance personnel receive updated training at least once every five years.

Training initiatives should target specific audiences. Facility or garage managers and frontline supervisors should receive additional training in the science of snow removal operations, effective winter storm management, winter materials inventory management, the chemical properties of salt and other winter materials, data collection/analysis, and salt usage trends.

In the fall of every year, an SHA expert at winter maintenance operations and salt management best practices conducts training at each of the 28 SHA maintenance facilities. This training session presents information on the previous season’s salt usage, equipment/storage upgrades, winter operations BMPs (Appendix C), and other winter topics relevant to any new initiatives. Internal outreach with our staff has had a huge impact on our salt reduction successes. Discussions encompass all aspects of SHA’s salt usage and our obligation, not only to the environment but the individual customer as well. The information communicated among all parties has been extremely beneficial, leading to the creation of best practices in our salt reduction strategies that will be useful for years to come.

Training should also be provided to hired equipment operators and temporary employees. The training (Appendix A) concentrates on the need to adhere to SHA snow and ice control policies and procedures. A major focus of this training should be on the proper use of salt and other winter materials. SHA provides online training prior to utilizing hired contractors.

Each of SHA’s current training presentations are contained as an appendix in this document. These programs are revised annually to reflect changes in operations that are developed through post storm/seasonal operational reviews, new materials, new equipment, and new technologies.

Should circumstances not allow in-person interactions between SHA managers, operators, or hired equipment vendors, technology will be used to convey any new presentations and initiatives.

## 7 Winter Storm Management

Winter storm management involves effective planning, execution, and review.

### 7.1 Weather and Pavement Condition Forecast

A key component of effective winter storm management is good weather and pavement condition forecasting. This is true 24 to 72 hours prior to a storm when planning is taking shape, during a storm as forces react to changing conditions, and during post-storm operations when effective cleanup actions prevent potential safety issues.

Agencies across the country rely on the National Weather Service (NWS), or contracted weather services; pavement condition forecasters; as well as their own network of Road Weather Information System (RWIS) sites and Mobile Advanced Road Weather Information Sensors (MARWIS) as tools for winter storm management. The NWS provides a strategic forecast, alerting agencies of the potential for storms well in advance of their arrival. As a storm nears, the NWS will provide forecasts for approximate starting times and snowfall amounts over generalized areas of a state. The NWS does not, however, provide localized site-specific forecasts, nor does it provide information on pavement temperature or conditions, which are key components needed by winter storm highway managers.

Contracted weather and pavement condition forecasters provide the generalized forecasting provided by NWS and enhance it with localized, site-specific information. The contracted services not only forecast when snow will begin to fall and how much is anticipated to fall, but also forecast the anticipated pavement temperatures which play a large part in how much snow will accumulate on highways or when it's practical to execute a chemical application. SHA uses a contracted Weather and Pavement Forecasting Services vendor that integrates Mobile Advanced Road Weather Information System (MARWIS) and Maintenance Decision Support System (MDSS) into winter operations. When coupled, these two practices will allow SHA to make better informed decisions when allocating resources during specific winter events.

The RWIS network is a series of strategically located local weather stations placed along an agency's highway system. Each weather station consists of a tower that provides localized data such as type and intensity of precipitation, air temperature, wind direction and speed, dew point, and relative humidity. Each station also has sensors in the pavement that detect pavement surface and sub-surface temperature, surface freeze point, and salinity concentration. RWIS networks can also include non-invasive pole or structure mounted pavement temperature sensors at critical locations that give pavement only data at specific sites, which eliminates the need to embed sensors in the pavement. The MARWIS devices have been localized to the areas where the greatest risk of snow/ice and colder temperatures exist in the state.

SHA relies on these four sources of information at each stage of its winter storm management. SHA maintains a close working relationship with the NWS and the contracted weather and pavement condition forecaster and maintains 55 RWIS stations across Maryland. SHA has also installed 99 non-invasive pavement sensors to fill in the gaps between existing RWIS locations. Beyond receiving regular reports from the weather forecasters throughout the winter, SHA engages in conference calls with them prior to and during significant winter weather events.

## 7.2 Pre-Storm Planning

Pre-storm planning is an effective tool for managing salt usage in a storm and a best practice in winter operations. Effective planning prior to storms will equate to better performance during a storm including more efficient usage of salt. SHA's statewide pre-storm planning for example, can begin as early as 72 hours prior to major winter storms. SHA's planning for typical winter storms begins 18 to 24 hours prior to events.

Agencies should begin resource planning well in advance of the forecasted start of a winter storm. Anti-icing should be performed, if appropriate, for the storm. Agency personnel and hired contractors, if applicable, need to report to their facilities or garages with enough lead time to thoroughly inspect plow trucks and make any minor repairs. All hired equipment units reporting for winter event operations should do so in effective, working condition. Any major repair should have been addressed prior to the season's start or immediately after the end of the previous storm. It is imperative that equipment is working properly and prepared for operations. Agency and hired truck operators should load salt and other deicing materials on their equipment in an environmentally prudent manner.

Agencies should consider holding pre-storm meetings with facility or garage personnel. These meetings would provide managers with an opportunity to alert personnel about the latest weather and road forecasts, emphasize the need for effective plowing, reiterate the need for sensible salting, identify appropriate salt application rates, and recommend the use for additives such as salt brine or magnesium chloride. It also allows for information exchange and a sharing of opportunities for improvement. Many SHA facilities routinely hold pre-storm meetings for all events.

Once the equipment is ready, it should be pre-positioned on its snow route prior to the start of the event. Pre-positioned snow equipment speeds up the response time of an agency. This is particularly important if the forecasted start time of the storm could affect morning or evening rush hour traffic. If snow fighting equipment becomes trapped by traffic congestion, it might not be able to get to its snow route in an acceptable time. A forecast that estimates a storm's start during rush hour also highlights the need for anti-icing roadways with salt brine, discussed below.

## 7.3 Anti-icing Operations

Anti-icing, a proven, proactive, nationwide winter strategy, should be practiced by agencies in Maryland whenever appropriate for a storm. SHA, for example, has been conducting anti-icing operations since the late 1990's. It has intensified the activity over the past several winters, addressing most highways in Maryland. Anti-icing involves placing a material, usually a liquid such as salt brine, on highways prior to the onset of precipitation. Anti-icing can also be accomplished with a pre-wetted salt placed on highways immediately before the start of a winter storm. Finally, it can be accomplished with an application of salt as snow is first starting to accumulate on a pavement.

The primary goal of anti-icing is to prevent snow and ice from bonding to a highway or bridge surface, allowing for more effective and efficient plowing and salting operations during the event. This will often lead to lower overall salt usage during storms and perhaps more importantly, an increase in the safety of motorists at the start of a storm. If snow or ice is allowed to bond to a pavement, heavy plowing and salting is needed to break the bond.

SHA's experience has shown that timely application of brine prior to the start of storms keeps highways in the best condition once frozen precipitation begins to fall. This is particularly important if a storm begins well in advance of its forecasted arrival time, and maintenance forces are not fully mobilized. The anti-icing application of brine becomes, in essence, the first application of salt that can "hold" the road until salt trucks can address the situation.

Highway agencies across the country, including SHA, do not perform anti-icing operations for every forecasted winter event. If a winter storm is forecasted to begin as rain, anti-icing will usually not be performed. In this case, rain would wash the salt brine off the highway surface, wasting materials,

time, and money. Additionally, if pavement temperatures are forecasted to be 15° or colder at the onset of the storm, anti-icing is not usually performed. Finally, if a winter storm had recently occurred and salt residue is present on highway surfaces, anti-icing might not be necessary.

#### 7.4 Winter Storm Operations

Once a storm begins and precipitation starts to accumulate on highway surfaces, agencies begin de-icing operations. If a typical winter storm begins with light snowfall, a light coat of pre-wetted granular salt or salt brine should be applied. If a winter storm begins with moderate to heavy snowfall, applications should be adjusted accordingly. Pre-wetted salt and salt brine tends to adhere to the pavement surface, ensuring the material remains on the roadway surface during the winter storm event, consequently reducing the amount of salt that bounces off the highway onto roadsides or into drainage ditches. Pre-wetted granular salt also dissolves into solution more quickly, which increases its effectiveness.

The key is to get material onto the roadway as early as possible to prevent snow or ice from bonding to the highway surface, but not so early that traffic moves it onto the shoulders, rendering it useless. This will allow for effective plowing and lighter salt applications throughout the remainder of a storm.

As the storm continues, forces need to react to changing conditions. As the initial application of salt begins to lose effectiveness and snow continues to build on highways, forces should begin plowing operations. If the initial application was successful, the buildup will be “mealy” and easy to remove with proper plowing techniques. The plow operator should re-apply just enough salt or brine to keep subsequent snowfall from bonding to the pavement. This process may have to be repeated multiple times during a winter storm. If a winter storm is associated with very cold pavement temperatures, granular salt should always be pre-wetted with a liquid deicer to increase its effectiveness. By increasing the effectiveness of salt, less will be needed.

SHA has several facilities that use brine not only for the initial pre-storm application, but also for re-application during the event. These shops have identified DLA snow routes and only treat the roadway with brine. This plowing operation consists of a designated snow route that uses only a salt brine solution to prevent the snow and ice from bonding to the pavement during. Unlike anti-icing, which takes place prior to the event, this strategy is performed for the duration of the event. SHA continues to promote the practical expansion of DLA routes throughout the state.

On multi-lane highways, plow trains (individual snow fighting equipment, such as plow trucks spanning diagonally across the travel portion of the pavement), should be considered to remove as much snow as possible in a coordinated sweep. SHA makes extensive use of plow trains. If a plow train is effective and the surface is passable, minimal salt is needed to keep the highway in an acceptable condition until the train comes through again. Every effort must be made by the train to direct the application of salt onto areas where plowing has already occurred. Otherwise, trailing trucks could plow off salt just placed on the road by the lead trucks. Agencies should train their forces in effective plow train operations, a key element in salt management.

Agencies should consider varying the LOS provided to motorists during storms based on resource availability, type/intensity of storm, location, and time of day. For example, if a storm occurs during the overnight hours, some snow can build up on highways if it is not allowed to become snow packed, the highway remains passable, and is in a reasonably safe condition. In this case, an agency can use less salt than it would otherwise. Conversely, if the same amount of snow falls on the same highway prior to, or during periods of heavy traffic, such as rush hour, more salting will be necessary to keep the road at a higher, or same LOS.

#### 7.5 Severe Winter Storms

Severe winter storms create unique challenges for a SMP. Agencies must be prepared to step up their response throughout the event, from pre-planning operations to final storm cleanup. They will be called upon to provide passable roadways, especially for emergency response, while fighting heavy

accumulations of snow, freezing rain, or blizzard conditions. SHA has fought several severe winter storms in the past and learned much in the process.

When fighting storms with heavy accumulations of snow, agencies should concentrate on plowing operations and limit salt applications. Plow trucks should still spread a small amount of salt and/or brine to prevent snow from packing on the road. However, the emphasis should remain on continuous plowing. As the storm begins to wind down and most of the snow has been removed, an appropriate amount of salt will help remove the remaining frozen precipitation from the surface. As in all other events, salt applications should be as efficient as possible. SHA adheres to this approach.

Freezing rainstorms also present special challenges to agencies. Freezing rain, if left untreated, will coat highways with ice, creating severe safety and mobility issues for motorists. SHA has found that the best treatment for freezing rain is pre-treating and reapplying salt brine, which prevents the ice from forming. A focal point during a freezing rain event is ensuring salt brine is placed and always remains on the roadway to prevent ice formation.

Some agencies use abrasives, such as crushed stone or sand, to provide traction for motorists. Agencies should consider a mix of salt and abrasives to lessen salt usage and still provide a level of safety for motorists. If a salt/abrasive mix is used during a storm, there may be a need for a cleanup of the abrasives from highways once the storm ends and the surfaces dry.

When preparing for freezing rainstorms, agencies should use a “shotgun approach”, where trucks are prepositioned at key locations along highway systems to ensure a quick response to likely trouble spots. While trucks are normally bunched together for snowstorms where plowing is necessary, they should be scattered using the “shotgun” approach in freezing rain events. SHA, for example, uses this approach which allows it to treat much of the highway system simultaneously.

Winter storms that occur at the start of or during rush hour traffic pose significant challenges to effective salt management. A winter storm that drops one or two inches of snow during rush hour can be more troublesome than a winter storm that drops five or six inches during off-peak travel times. SHA and other agencies have learned that they must place pre-wetted salt or brine on highways prior to heavy traffic. Once traffic builds up on highways, plow and salt trucks cannot address snow buildup. In addition, snow can be “packed” on the highway surface, requiring very heavy plowing and salting to remedy it. Appropriate applications prior to rush hour is one of an agency’s best tools in limiting total salt usage during this type of event.

Severe winter events such as blizzards or back-to-back storms create unique challenges to agencies and effective salt management. While normal plowing and salting can keep a highway in a passable condition during a typical winter storm, heavy snowfall requires more intensive plowing operations. Cycle times of plow trains to cover their assigned route are severely challenged with heavy snowfall storms. In these events, agencies should still apply salt, at a reduced rate, during each plow train cycle.

This is critical if snowpack or icepack is to be avoided. Salting should keep subsequent snowfall in a plowable state, so it can be addressed in the next plowing cycle.

Agencies do not usually have sufficient equipment and personnel to run plow trains for hours on end. Equipment breakdowns can eventually affect the operation. In addition, it is critical that agencies provide adequate rest for their employees during severe storms. This keeps operators fresh, so they can make good choices while plowing and salting, and repair technicians fresh so they can keep equipment operable. An appropriately rested workforce should translate into effective salt management.

Some winter storms are so severe that the Governor may declare a State of Emergency, allowing for the utilization of additional resources, such as the National Guard. Additionally, authorities have the option to limit the amount and type of vehicle travel. When this occurs, highway agencies should clear

roads of snow and ice in a more effective manner. During a State of Emergency, SHA re-prioritizes its roadways to focus primarily on interstates, US routes, and roadways with high ADT. This focus ensures passable primary roadways for emergency equipment and intrastate commerce.

## 7.6 Stockpiling and Disposal of Removed Snow

During blizzards or back-to-back storms, snow can build up to a point when it cannot be plowed. Some municipalities have difficulty plowing snow in heavily populated or congested areas. In these cases, snow needs to be hauled away in dump trucks. Agencies need to coordinate with the MDE and the Maryland Department of Natural Resources (DNR) to identify storage locations for the snow in less environmentally sensitive areas. These pre-approved locations can be used to store snow, which may contain salt or other materials, until it melts over time. Another option is to use snow melting systems to speed up the operation. This is important if the holding area needs to be cleared to physically hold more snow.

## 7.7 Operations in Sensitive Areas

Maryland Public Works Departments and local highway agencies should coordinate with MDE to determine criteria for determining areas sensitive to exposure to salt and salt runoff. While MDE and SHA recognize the importance of all waters in Maryland, areas of high susceptibility were determined to be:

- Wetlands of Special State Concern as defined in COMAR 26.23.06
- Tier II waters as defined in MDE's Total Maximum Daily Load (TMDL) Integrated 303D Reports
- Use III, non-tidal cold-water streams or Use III-P, non-tidal cold-water streams – public water use
- Wellhead Protection Program as defined by MDE's program.

In addition to the areas of high susceptibility, SHA and MDE also agreed that roadside and/or receiving waters exhibiting indicators of salt contamination should be monitored and salt management practices in those areas should be assessed to determine if changes in practices and salt usage can effectively be implemented.

Site specific plans for environmentally sensitive areas should be considered. A plan for a sensitive area may include reduced salt usage or no salt usage at all. It may also include the use of another snow and ice control material. These sensitive areas are taken into consideration when identifying potential DLA snow routes. These routes should be known to all who perform salting operations, as well as to the public using Maryland roadways.

The potential for reduced levels of service exists for motorists when normal plowing and salting operations are not conducted in sensitive areas. Signage alerting motorists about the reduced levels of service may be required to indicate the need to slow down and remain alert.

Agencies should develop new strategies and test new technologies in these areas that may lead to improved service without impacting the environment. SHA, for example, is piloting the Maintenance Decision Support System (MDSS) at several sites in Maryland. The program provides a high-resolution weather and pavement forecast for snow routes and recommends material application rates based upon data received during winter operations. The program attempts to find the lowest amount of salt or other winter material application rate while still maintaining an agency's acceptable LOS.

## 7.8 Automatic Vehicle Location (AVL)

A critical component of effective winter storm management is knowing where snow fighting equipment is always located. Many agencies across the

country have deployed AVL systems to help in this effort. The AVL system tracks the physical location of dump trucks and other snow fighting equipment during winter storms and displays results on monitors. The AVL system is a tool for managers to track progress during winter storms. It can be used by managers to locate and deploy the nearest truck to a highway incident, speeding up emergency response.

SHA deployed a new AVL system prior to the start of the 2022 winter season. This new system will have the capabilities to display route completion, track cycle times while adjusting to LOS desires, and display route decay. Route decay is defined as LOS degradation when comparing the last time a route was treated versus the estimated cycle time of the route. Once a route has been completed the map will show green in color and as cycle time goes by, without another treatment, the route will incrementally change color eventually ending up as red on the map. This feature will allow Winter Operations Managers to quickly assess any issues or “hot spots” and react accordingly by shifting resources, if necessary. The new AVLs will also provide real time operational equipment data that could potentially keep vehicles from having catastrophic mechanical failures.

An AVL system can also be used to determine the material application rate at which a truck is plowing and spreading salt. Data captured through the AVL system can be analyzed after winter storms to identify opportunities to increase the efficiency of winter operations. Finally, and perhaps most importantly, AVL is a tool to increase the safety of the drivers.

New AVL units were placed in all SHA dump trucks, supervisor’s vehicles, and other specialty equipment. Portable AVL units were also issued to many contracted trucks that perform snow removal for SHA.

## 8 Post Storm Operations

Post Storm Operations include a variety of tasks including cleaning equipment, stockpile maintenance, and operation reviews.

### 8.1 Equipment Cleaning and Maintenance

Agencies should develop plans for equipment cleanup and maintenance after winter storms. Cleaning of snowplows and trucks should occur immediately after operations are complete, when possible.

These cleaning operations should occur inside the wash bays at the facility. Cleaning of salt spreaders and plow blades that have been removed from vehicles should occur in a manner whereby wastewater does not discharge into stormwater systems.

SHA maintenance facilities where vehicle maintenance occurs are required by MDE's General Permit for Discharges from Stormwater Associated with Industrial Activities (Discharge Permit No. 12-SW) to develop and implement a site-specific Stormwater Pollution Prevention Plan (SWPPP). While the SHA plans are site specific, they all contain consistent protocols, inspections, documentation, and reporting requirements related to potential pollution sources such as equipment cleaning and maintenance operations. Should a plan not already exist, one should be developed.

### 8.2 Material Cleanup at Storage Facilities

Immediately after winter storm operations have ceased, all unused salt should be returned to a storage facility. All exposed abrasives should either be moved to a covered facility or covered securely with a tarp. If salt/abrasive mixing has occurred in an uncovered area, any remaining stockpile should be returned to the salt storage facility. SHA's SWPPPs, for example, include requirements for material storage at maintenance facilities.

### 8.3 Operations Review for Continual Improvement

An agency review of operations after winter events is an essential best practice in winter operations and salt management. Agencies in Maryland should consider having post storm reviews at their maintenance facilities for most winter storms and agency-wide reviews for major storms.

Post storm reviews should concentrate on three key elements: what worked well, what did not work well, and most importantly, opportunities for improvement. The opportunities for improvement lead to best practices. Post storm reviews can also be used to identify "champions" who get snow routes cleared with less salt. The "champions" should be encouraged to share ideas with others at the facility to encourage and promote efficiency in salt application.

### 8.4 Post Storm Data Analysis

Agencies should consider capturing salt usage data by truck, snow route, facility or garage, district, and agency wide. Facilities should consider measuring salt usage in relation to the number of lane miles served, and inches of snow fought. One formula for measurement is "pounds of salt used per lane mile per inch of snow". In this process, agencies can measure the salt usage performance between trucks on a common route, routes within a single facility or garage, and from facility to facility or garage to garage.

Agencies should also consider electronic means of collecting salt usage data. Various electronic salt spreader controllers have this capability. At the close of a winter storm, data on salt usage can be downloaded from the spreader and analyzed by facility managers. Agencies should also consider using AVL



technology for salt usage data collection. AVL technology has the capability of identifying salt usage and when and where each application was made. Additionally, SHA is piloting the use of loader scales to accurately measure the amount of salt being loaded into trucks in lieu of estimating weight by the number of scoops. In conjunction with this pilot study, SHA is researching the potential use of radio frequency identification (RFID). This concept would use active RFID installed in the loader to communicate with passive RFID installed on the truck. The loader would identify the truck unit and document the weight in salt being loaded into the truck and communicate that information back to the manager in the facility. Along with helping to better manage the use of salt during an event, this concept could potentially allow for more accurate re-order of salt for the barn or dome after the event, preventing the facility from being overloaded.

## 9 Spill Prevention and Control Plan for Winter Operations

First and foremost, agencies should make every effort to prevent the uncontrolled release of winter materials into the environment at storage facilities and on highways. SHA, for example, developed and implemented site specific SWPPPs for each of its maintenance facilities. The individual plans consider potential sources of stormwater pollution and describes practices to reduce these potential pollutants. While the plans are site specific, they all contain a common approach to spill management of winter materials.

### 9.1 Salt Spill Prevention

When loading salt at storage locations, trucks should never be overloaded. If they are, salt can spill from the sides or back of the truck when it is leaving the facility or when it is on route.

Overloading trucks with salt should be avoided and is a clear violation of best practices for salt management. If spillage occurs, it should be addressed during a storm if time allows or at the close of the event.

Another best practice is the deployment of tailgate flaps that prevent salt from spilling out of the back of dump trucks. These small triangular pieces of metal can be made in house for a few dollars but can save tons of salt over the course of a winter season. SHA requires tailgate flaps on all state and contractor trucks.

There are times when salt can spill from a truck that was not overloaded. If the auger in a truck's salt spreader box becomes jammed with a large chunk of salt or debris, the operator may have to manually clear the box. At times, the jam is cleared but salt falls to the pavement. At other times, a truck operator may have to raise the dump truck bed to move material to the rear of the truck. This occurs when the salt in the bed of the dump truck begins to get low. During this operation material can spill from the rear of the truck.

Whenever salt spills from a truck, either from being overfilled or not, it should be swept up and placed back in the bed of the dump truck. Operators must do this in a safe fashion so as not to endanger themselves or motorists. Effective salt management does not equate with unsafe practices.

### 9.2 Brine and Magnesium Chloride Mixing and Storage Tanks

To minimize the possibility of leakage and spills from liquid storage tanks, a weekly inspection program, during a facility environmental walkaround, should be implemented, and secondary containment should be installed. Whenever drips/leaks are found, maintenance and/or repairs should occur immediately. Until the repair can be completed, the leak should be contained if it is located outside of the secondary containment.

## 10 Recordkeeping and Annual Reports

Agencies should keep up-to-date records of all winter operations, especially records of salting. Records should be kept for each winter event, and for each winter season. This will allow for seasonal analysis and the identification of trends. SHA maintains up-to-date records of salt usage and other key performance measures and produces quarterly and annual reports for its statewide business plan.

SHA has been keeping extensive electronic records of winter operations since 1999. SHA tracks personnel, equipment, and material usage (to include salt and brine) at each of its maintenance facilities. It also tracks weather and pavement conditions during winter events. The information is summarized in various reports for real time operations status and is post-processed for operations cost estimates. SHA continues to research opportunities to further use technology in support of data gathering.

Like SHA, agencies should perform an in-depth analysis of winter operations, with an emphasis on salt usage, at the close of each season and periodically during the season. This analysis should culminate in an annual report. The annual report should serve as means for learning lessons, identifying opportunities for improvement, identifying trends, and developing recommendations for operations for the following winter. The annual report can also be used by an agency's senior management to determine the need for changes in policies, procedures, processes, and expenditures and to determine any budgetary implications of identified needs.

## 11 Annual Winter Wrap-Up Meeting

Agencies should hold an annual meeting to review winter operations, deepening their understanding of lessons learned from post storm reviews, and identifying areas of concern such as salt management, equipment improvements, etc. The annual meeting can be used to identify key opportunities for improvement and set up teams to tackle them over the summer. It is critical that the progress of the teams is tracked closely so that the efforts come to completion prior to the following winter.

## 12 Public Education and Outreach

Agencies should make every effort to provide the public with information concerning their winter operations and winter storm activities. Agencies should consider an annual media briefing to update radio stations, television, and print media in their area about their winter operations program. Agencies can use this opportunity to review their experiences during the past winter, discuss their plans for the upcoming winter, and highlight new initiatives. This information could then be shared, through the media outlets, with the public.

SHA's Office of Communications, for example, holds an annual "Snow Show" each fall for its outreach to the public, inviting the media for coverage to ensure the public is aware of how SHA is prepared for the winter season. During the briefing, SHA stresses the need for motorists to be mindful of the potential dangers of driving during winter storms. They highlight their "Ice and Snow, take it Slow" or "Don't Crowd the Plows" campaign as well as their message to stay home during winter weather events. SHA also stresses the need for motorists to give snow fighting equipment space to do its job.

Agencies should consider having their emergency operations centers activated for winter storms and using them for outreach. SHA's Office of Communications, for example, provides live interviews with media representatives in a proactive manner, as well as posting events on social media. This allows SHA to keep the public, via the media representatives, updated on the status of its operations and the overall condition of the highway system.

Agencies should also consider providing customer service for their citizens during and after winter storm events via telephone and internet. An agency's maintenance facilities or garage personnel or its emergency operations center can respond directly to citizen needs in real-time on a localized basis. General questions about operations can be handled through the facility or garage managers or by the agency's office personnel.

SHA deployed a public facing website where our customers can view every single piece of snow fighting equipment used during any given winter event. This was developed due the organization wanting to be transparent, as legally and safely possible, with our winter operations deployment. While no personal information is shared with the public they can see exactly where a piece of equipment has been within the last 30 minutes and use this information to make better decisions on whether to travel or not during the storm.

## 13 Testing and Evaluation of New Materials, Equipment, and Strategies for Continual Improvement

Agencies should always be striving to continually improve the efficiency of winter operations. One way to improve operations is by testing out well-researched new ideas that pose minimal risk to operations but have a substantial upside. The new ideas can be in the form of different types of winter materials, updates to existing standard operating procedures, deploying new spreader plows or other winter equipment, or implementing new strategies or tactics for fighting storms. Testing and evaluating new technologies can lead to lower salt usage and is a Best Practice for Salt Management.

SHA, for example, has tested and evaluated tow-behind plows, a trailer mounted plow that is towed by a dump truck. The tow-behind plow, in conjunction with the dump truck's front plow, can clear a path 24 feet wide, while a standard front plow can only clear a section of roadway eight feet wide. SHA is also exploring the use of graphical displays using its GIS program to improve practices in salt management.

There are many organizations across the country that are performing research on new winter strategies, testing new materials in laboratories, and evaluating the effectiveness of new products on highways and bridges. Agencies in Maryland should consider and take advantage of these resources, most of which are free of charge to others in the winter maintenance community. The following links provide information about these research organizations:

<http://www.clearroads.org/>

The Clear Roads pooled fund project provides real-world testing in the field of winter highway operations. This ongoing research program has already attracted 34-member states and is funding practical winter maintenance research.

<http://www.aurora-program.org/>

Aurora is an international partnership of public agencies that work together to perform joint research activities related to Road Weather Information Systems (RWIS). This website is designed to introduce the program, the partners, and its collaborative research projects.

[Snow & Ice - FHWA Road Weather Management \(dot.gov\)](http://www.fhwa.gov/sicop/)

The Road Weather Management Program, within the FHWA Office of Operations, seeks to better understand the impacts of weather on roadways, and promote strategies and tools to mitigate those impacts

<https://sicop.transportation.org>

Advocates transportation-related policies and provides technical services to support states in their efforts to move people and goods efficiently and safely. The Winter Maintenance Technical Services Program addresses AASHTO's goals for the snow and ice control community.

<http://pnsassociation.org/>

The Pacific Northwest Snow-fighters (PNS) Association strives to serve the traveling public by evaluating and establishing specifications for products used in winter maintenance that emphasize safety, environmental preservation, infrastructure protection, cost-effectiveness, and performance.

## 14 Summary

Agencies should view these Best Practices for Salt Management as a starting point in their winter operations. Agencies should always strive for effective salt management and road safety.

Agencies should also seek opportunities to work with various regional, county, and local organizations to provide seamless operations during winter storms. However, agencies need to be cognizant of the fact that other agencies will have different needs based upon public safety, geography, traffic and weather patterns, environmentally sensitive areas, available resources, budgets, and constituency expectations.

Maryland's highway agencies should seek opportunities to consult with each other after major winter storms and after the completion of winter seasons to share lessons learned in Best Practices for Salt Management.

Best Practices for Salt Management is a living document updated on a regular basis. In that regard, SHA will attach a series of appendices to this document. They will address issues such as training, pre-storm checklists, post storm reviews, and material handling. In addition, SHA will continue to attach appendices to this document as new information becomes available. Best Practices for Salt Management should be a key tool to provide the citizens of Maryland with safety and mobility during winter storms in a cost-effective, environmentally sustainable manner.

## 15 Appendix A: Hired Equipment Presentation



# The Maryland State Highway Administration



## Winter Hired Equipment Presentation

revised 08/14/2023

# Presentation Agenda

- Invoicing/Contract Item Number(s)
- Right to Audit Clause
- Conflict of Interest Clause
- Insurance/Registration
- Contractor/Equipment Requirements
- V-Box Spreader Systems
- Green Emergency Lighting
- Salt Usage/Environmental Impacts
- Plowing Best Practices
- Social Media
- FMCSA Regulations
- COVID/Virus Protocols
- Equipment/Facility/Structure Damage

# Invoicing Requirements

- Winter invoices are required to be submitted by email this winter season
- A valid email address shall be listed on the Contractor Equipment Statement in the Contract
- Electronic signatures will be used for this process
- All supporting documentation is required to be submitted with each winter invoice

# Item Number(s)/Invoicing

- Item number(s) have been established for equipment type/configurations in the Contract
- These will be required on the Contractor Equipment Statement and all invoices
- If item number(s) and equipment type/configurations are not included on the Contract/invoices this will delay payment

# Insurance/Registrations

- All insurance policies/registration(s) must be maintained, at a minimum, from November 1, 2023 through April 30, 2024
- The failure to maintain all insurance/registration requirements throughout the term of the Contract will be cause for termination of the Contract and will void the post-season retainer and any remaining minimum payment guaranteed due to the Contractor
- The Contractor shall make SHA aware of any changes to the status of certificate(s) of insurance or registration(s) within five (5) calendar days

# Contract Discrepancies

- This is a non-exclusive Contract. It does not include all work expected to be performed in the designated areas. Therefore, at times, other Contractors may be performing similar work that is not associated with this Contract.
- Should there be any discrepancies between the Contract and actual field conditions or any other circumstances, the RME or designee shall make the final determination.

# Winter Operations

- Safety is SHA's number one priority during all snowstorm activities
- Snow removal equally shares first priority regarding highway maintenance operations
- SHA and Contract forces are jointly responsible for minimizing impacts to our environment and minimizing winter operations costs



# Winter Operations

- SHA's policy states that winter operations will continue until all state roads are free from snow and ice
- If needed, relief operators shall be employed by the Contractor and shift changes shall occur on the assigned snow route or at a pre-determined location
- Contractor operators/equipment are not exempt from any FMCSA laws or regulations, including hours of service, while performing winter operations for SHA





# Contractor Equipment Requirements

- All equipment used for snow removal operations **SHALL** have met the Contract requirements
- All equipment used for snow removal operations **SHALL** be approved by SHA and listed on or added to the Contract prior to its use
- If any equipment used by the vendor is found to be non-compliant and in breach of the Contract, it may be terminated

# Snow Removal Requirements

- Operators are required to have all equipment calibrated and operational prior to check in
- All contract personnel and equipment must be logged in and out of service and, at the request of the facility, operators must provide their cell phone number
- ***NO REPAIR DELAYS!*** All equipment should be ready for work upon arrival
- SHA will not pay for down time on trucks and equipment that extends beyond one hour. This will include any piece of equipment that is involved in an accident, at fault or not.

# Snow Removal Requirements

- All CB radios must be in good working condition
- Check with your Snow Supervisor for the appropriate channel
- SHA equipment being utilized by contract forces shall **NOT** be used for any other work



# Automatic Vehicle Location (AVL)

- AVL technology will be used to track the current and past locations of SHA trucks and select contract equipment
- AVL technology will increase the efficiency, effectiveness, and safety of SHA and contracted equipment operators

# Automatic Vehicle Location (AVL)

- The Contractor's truck shall provide a 12-volt DC Power Port or other similar power source for the plug-in AVL unit
- The power source shall be in the truck's cab in order to protect the AVL unit from damage
- The Contractor's equipment may be fitted with an AVL unit at the pre-season inspection
- The Contractor's personnel may be asked to sign a form accepting the AVL unit for the winter season

# Automatic Vehicle Location (AVL)

- The AVL unit must be kept operational throughout the storm and returned, in working order, at the close of the winter season
- Failure to keep the AVL unit powered during winter operations will result in a 50% deduction from the post-season retainer
- A second occurrence will result in no post-season retainer and the contract may be terminated
- The Contractor will have \$500 deducted from post-season retainer for failing to return the unit in working order at the end of the winter season



# V-Box Type Spreader System

- At the request or discretion of the RME or designee, Contractors may opt to use an equivalently sized V-Box type spreader/delivery system
- The RME or designee shall make the sole determination as to whether the equivalently sized V-Box type spreader/delivery system meets the needs of the Administration
- There shall be no additional compensation for the use, maintenance, repair, or any damages to an equivalently sized V-Box type spreader/delivery system on a hired piece of winter equipment



# Green Emergency Lighting

- Per House Bill 1150, green emergency lights may be used on emergency vehicles participating in winter operations
- However, if incorporated, the number of green lights must be equal to or less than the number amber lights
- All lights, regardless of color, must be provide 360-degree visibility form within 50 feet of the vehicle



# Call-Out Phases

- Each storm is evaluated based on the forecasted accumulation and severity
- Report times can be accelerated based on intensity of the storm, timing of the event, and other factors beyond SHA's control
- SHA will consider all factors when determining the proper response for each event

# Call-Out Phases

- **Phase 1** - (0-1 inch forecast or <0.1 inches of freezing precipitation) Includes only SHA Trucks
- **Phase 2** - (1-2 inch forecast or 0.1 to 0.2 inches of freezing precipitation) Includes Phase 1 trucks and hired spreader trucks to supplement SHA work forces on designated routes where there are no assigned SHA trucks

# Call-Out Phases

- **Phase 3** - (2-4 inch forecast or  $>0.2$  inches of freezing precipitation) Includes Phase 2 trucks and hired spreader trucks to supplement the SHA work forces during heavier snowfalls
- **Phase 4** - ( $>4$ -inch forecast or major freezing precipitation) Includes all Phase 3 trucks and hired push trucks to supplement SHA work forces on designated routes as roadway conditions warrant

# Statewide Salt Usage Trends

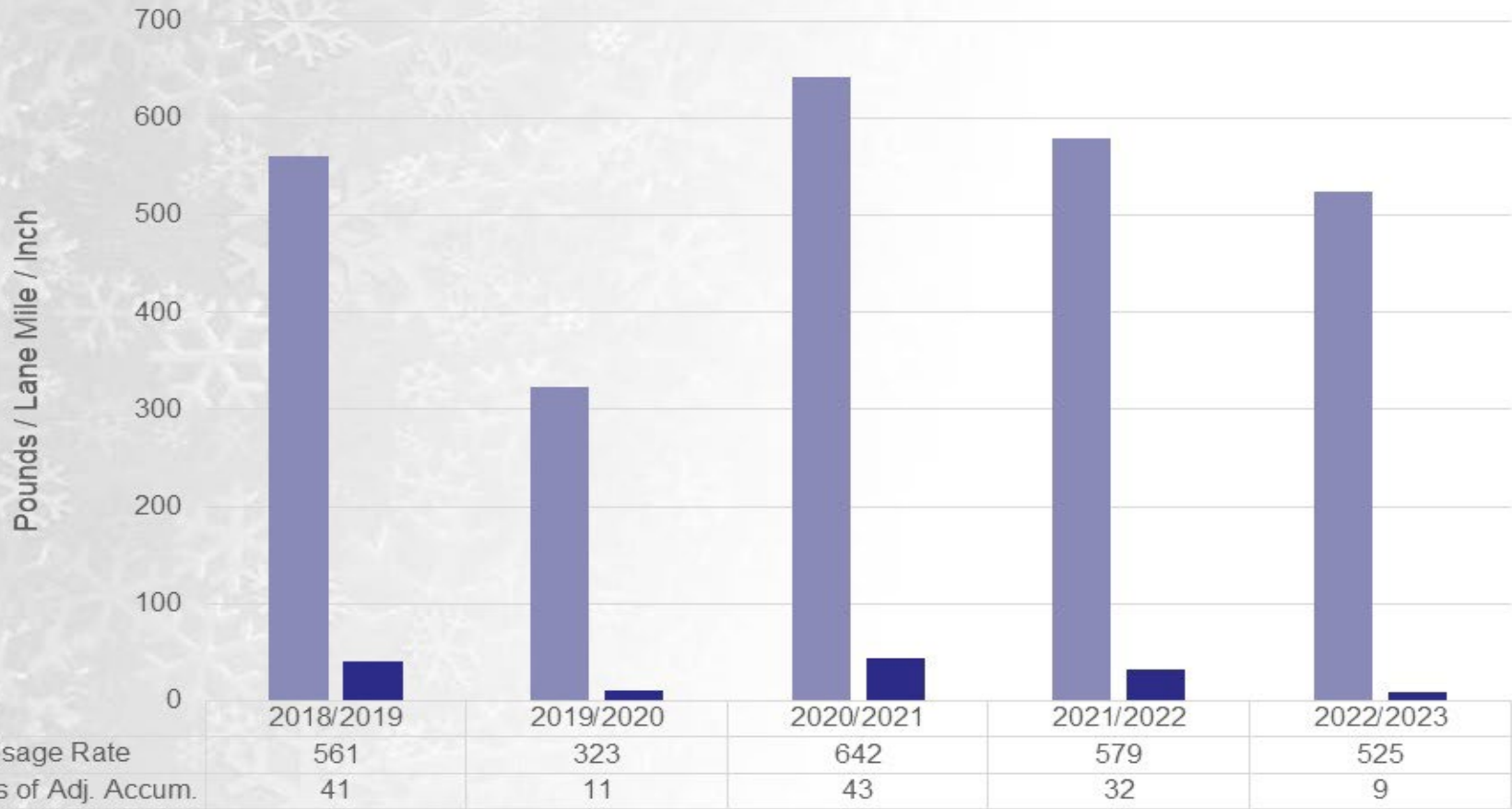

■ Salt Usage Rate    ■ Inches of Adj. Accum.

# Salt Impacts on the Environment



***So, what's the big deal?? Salt is a naturally occurring substance!***

While salt is a naturally occurring substance, high concentrations of salt negatively affect or destroy land and aquatic habitat/species

# Salt Impacts on the Environment

- 
- Once granular salt mixes with snow or ice it becomes a brine solution. This solution then runs off the roadway and is forever stored in soil or water and can reach levels that are considered unhealthy to the environment
  - Salt will contaminate drinking water supplies in wells and in reservoirs, slows the establishment of vegetation or crops, and destroys waterways for fish and other marine life



# Salt Impacts on the Environment



Dumping salt in this area killed the vegetation and the area was at risk for erosion. This area had to be restored by removing contaminated soil, backfilling and seeding and mulching.

# TMDL

- **Total Maximum Daily Load**
- Definition: a regulatory term in the U.S. Clean Water Act, describing a value of the maximum amount of a pollutant that a body of water can ingest daily while still meeting water quality standards
- TMDL's already exist for phosphorus, nitrogen, and sediment for many watersheds and waterways in Maryland





# TMDL

- TMDL's for Chlorides (salt) are not currently being applied to Maryland watersheds, but 28 watersheds have been designated as impaired
- Once a TMDL is placed on a watershed or waterway it carries heavy fines if not adhered to
- SHA and its vendors should continue using internal BMPs to stave off the possibility of TMDL implementation

# TMDL

Ask yourself these three simple questions when it comes to TMDL's and salt usage...

Do I enjoy spending time outdoors and enjoying some of Maryland's finest seafood?

Do I value the drinking water, health and well being of my spouse, child, or elderly parent?

Is there something I may be able to do different to make a difference?



**YOU play a more prominent role in protecting our environment during winter operations than you may have originally thought**

# Practical Salt/Brine Usage

- A well-trained operator knows when to apply salt/brine, and when not to
- Use the correct amount of salt/brine necessary to get the job done
- Using more salt/brine than necessary works against you and damages the environment





# Practical Salt/Brine Usage

- Never overload trucks to avoid spillage of salt at SHA facilities and on the road
- Always travel at a safe speed for optimum performance, safety, and to help keep salt on the road and out of the roadside ditches



# Practical Salt/Brine Usage

- Always keep your load covered to avoid unnecessary loss of material when traveling
- Don't salt/brine roads that have already been salted
- Only apply salt/brine to your designated snow route when directed by SHA personnel
- Always use appropriate shop/brine application rates or rates as directed by SHA management

## Practical Salt/Brine Usage

- Don't apply salt/brine to an undesignated snow route unless directed to by SHA personnel
- All unused salt/brine must be returned to the dome or barn that it was loaded from
- Never spread salt/brine just to get rid of it

# Best Practices for Plowing Safety

- Be aware of the weight of heavy snow and the damage it can cause when thrown by a plow



- Never plow snow over bridge parapets or jersey barrier walls - that could endanger traffic and/or pedestrians below



# Best Practices for Plowing Safety

Watch out for manholes, railroad tracks, expansion joints, bridge abutments, utility cuts, mailboxes, etc.



# Best Practices for Plowing Safety

Watch for curbs and steel plates...



# Best Practices for Plowing Safety

Be aware your truck's bed height - watch for overhead signs, traffic signals, utility wires, tree limbs and bridges





# Intersections

- Empty your plow before crossing intersections
- Reduce the size of the windrow
- Avoid building snowbanks that interfere with sight distance
- Keep traffic signs unobstructed from view

# Ramps and Curves

- Plow ramps and curves from the high side to the low side
- Spread salt/brine on the high side of ramps and curves
- Keep your speed down on all ramps and curves

# Bridges and Overpasses

- Bridge surface may be higher than the road surface due to the bridge freezing and expanding
- Care must be taken not to throw snow over the bridge to the road below
- Keep the sidewalks on bridges open for pedestrians

# Shoulders, Medians & Jersey Barriers

- Plow away from medians with minimum width shoulder and barrier wall
- Avoid plowing snow against a jersey barrier as this creates a ramp for vehicles to possibly become airborne

# Mountains and Hills

- Traction is limited on hills
- Stopping can be difficult on hills
- Watch for melted snow refreezing in the road valley



# Railroad Crossings

- Avoid piling snow against signals, switch boxes, signs, etc.
- Raise plows slightly when crossing railroad tracks
- Watch for flashing lights and mast arms blocking the roadways

# Two Way Road Single Truck

## First Pass

Plow lane in one direction and drop salt behind truck

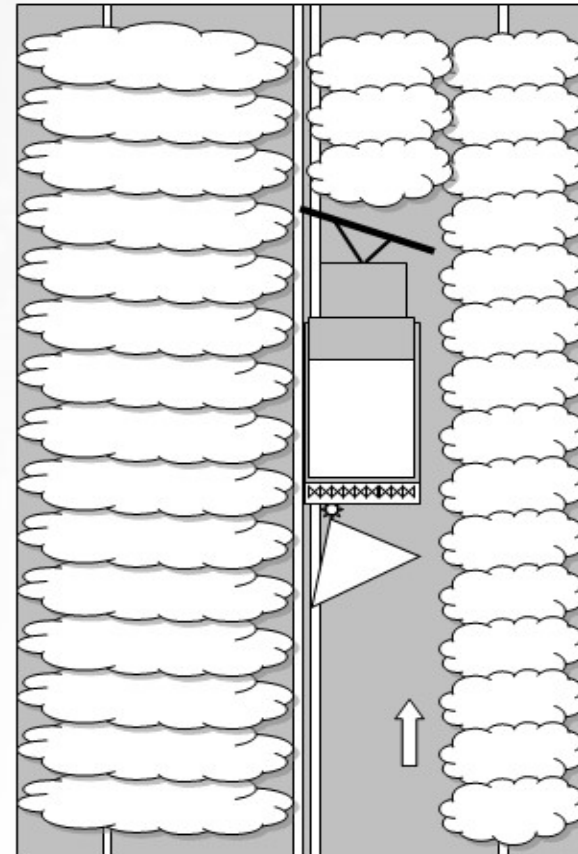

# Two Way Road Single Truck

## Second Pass

After plowing in one direction, turn at end of route, plow lane in opposite direction and salt both lanes

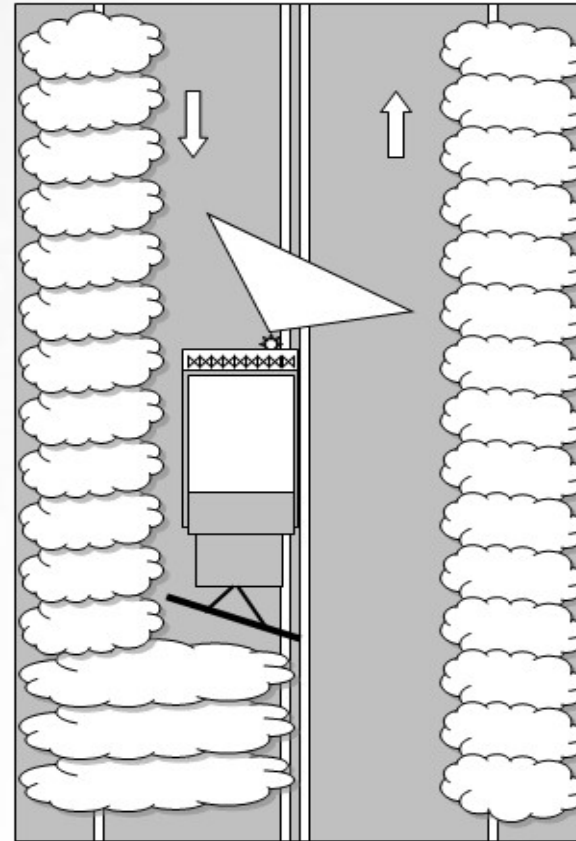

# Two Way Road Two Trucks

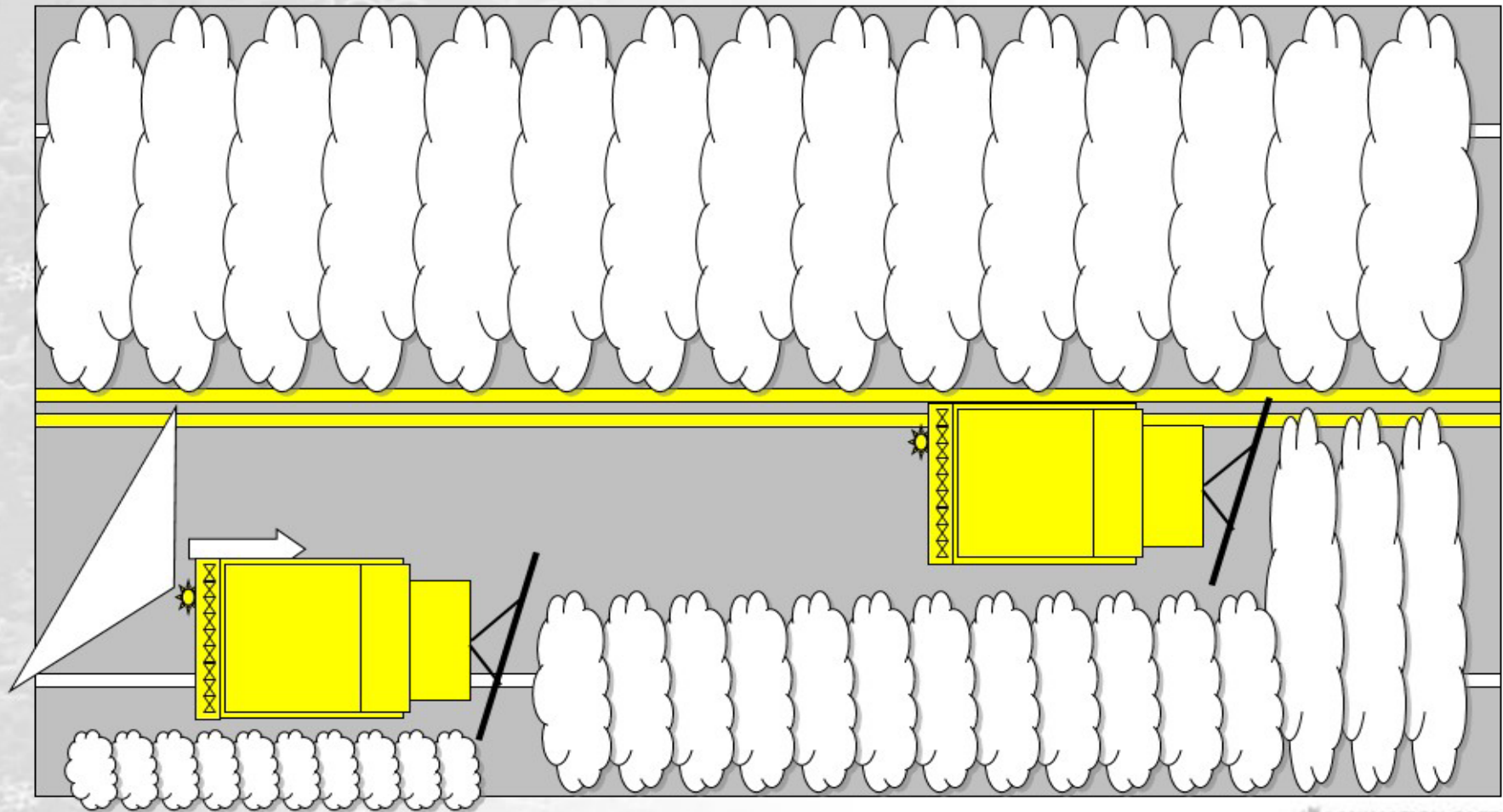

# Multi-Vehicle Plowing

- The deeper the snow, the more overlap needed to avoid leaving a windrow
- First truck clears 8 feet of the left traffic lane, leaving 4 feet for second truck
- Second truck overlaps 1 foot clearing 4 feet of first lane and 3 feet of second lane, leaving 9 feet for third truck

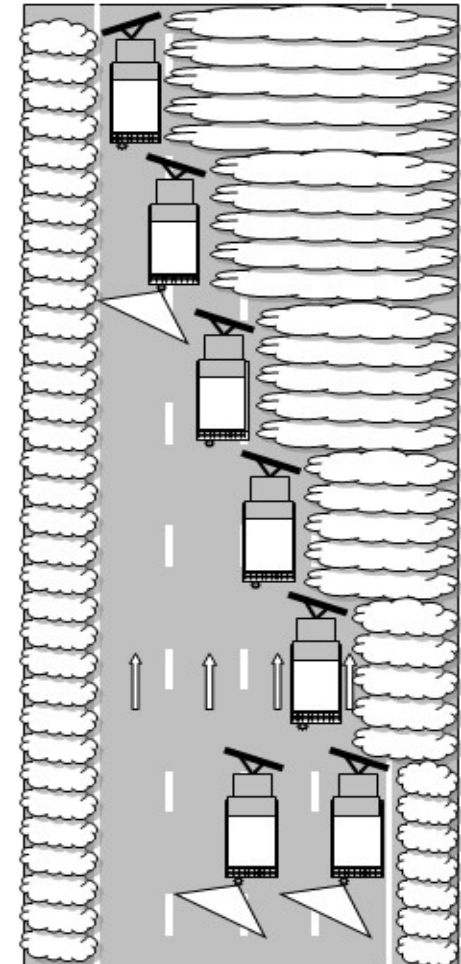

# Multi-Vehicle Plowing

- Third truck overlaps 1 foot clearing 7 feet of second lane, leaving 2 feet for fourth truck
- Fourth truck overlaps 1 foot clearing 2 feet of second lane and 5 feet of shoulder
- One more truck would be required if a third lane was present

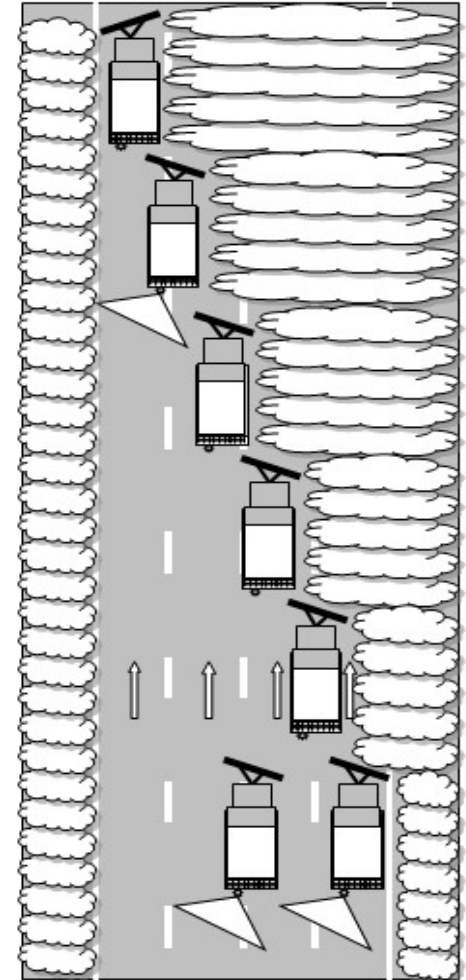

# Multi-Vehicle Plowing

- Four or more lanes would require more plow trucks
- The larger trucks should be at the end of the train
- The last truck plows ramps

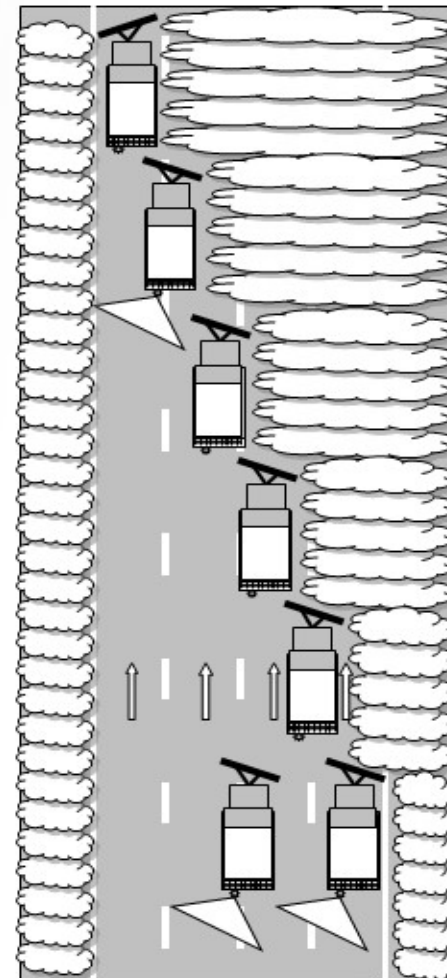



# Plowing Points to Remember

- Always give bridges and ramps special attention
- Salt/brine the high sides of curves
- Do not over-use salt/brine. Use just enough to get the job done
- Designate specific trucks in a plow train for salting to ensure no overlap of resources

# Plowing Points to Remember

- Salt loses most of its effectiveness at temperatures below 20°F
- Adding more salt to an already salted roadway can actually cause the brine solution to freeze
- Salt stops working altogether at - 6°F

# FMCSA Regulations

- All applicable FMCSA regulations apply to equipment and operators
  - This includes, but not limited to, Hours of Service
- Contractors are not covered under SHA's emergency exemption during winter events

# Operator Guidelines

- Always contact your SHA supervisor prior to leaving your designated snow route or if you get separated from your assigned SHA truck
- Show up or commute time, from the designated SHA facility to assigned route, must not be excessive

# Operator Guidelines

- Always communicate the need for fuel or meals with your snow supervisor prior to leaving your assigned route
- Coordinate all refueling to minimize disruptions to the snow removal operations



# Operator Guidelines

- Check the cutting edge of your plow before each event to avoid damage to the plow structure
- When working for SHA, DON'T plow and salt parking lots, driveways or roads that do not belong to SHA

# Operator Guidelines

- Relief operators shall be changed out on their snow routes or at predetermined location approved by SHA
- All trucks loaded with salt while on standby or just plowing should be covered to avoid freezing



# Social Media Usage

- Operators shall not post anything SHA related on social media while performing winter operations for the Administration
- This could lead to negative public perception of SHA winter operations
- It may also lead to legal issues should an accident or an act of environmental non-compliance occur

# Accidents and Damage

- Always maintain a heightened state of awareness when working around salt structures or out on the roadways
- Report all accidents involving SHA equipment or facilities promptly to the snow supervisor and obtain a police report
- SHA will not be held responsible for damage incurred to the Contractor's vehicle while carrying SHA's snow removal equipment

# Accidents and Damage

- Upon returning to the shop, the driver will stay with their truck and assist with the repairs of SHA equipment
- If a repair part is required at the shop, all repair parts must be acquired by a shop mechanic
- All damaged or non-operating equipment must be reported to the snow supervisor, repaired ASAP and/or prior to the next storm

# Overhead



# Structure Hits

# Overhead Structure Hits

- Keep truck bodies lowered when traveling
- Use extreme caution when raising to fill the auger box
- Remain aware of your surroundings:
  - signals
  - utility wires
  - overhead signs
  - bridges



# Overhead Structure Hits

- The “Notice of Unsatisfactory Performance” will now allow post-season retainers to be deducted and your contract terminated for multiple infractions
- Contractors will be responsible for cost of damages due to any negligence
- **SO PLEASE BE VIGILANT...**

**Thank You For Your Attendance!**

**There is no better time than the present to express our appreciation for your support**

**The State Highway Administration thanks you for making a difference towards our winter snow removal activities**



## 16 Appendix B: Snow College Presentation

# SNOW COLLEGE



The Maryland State Highway Administration



## WINTER OPERATIONS OVERVIEW

- **The primary objective for all maintenance personnel during winter operations is to make every effort to maintain all roadways under their jurisdiction in a safe and passable condition throughout a storm.**
- **To provide an exceptionally high level of service to our customers at the lowest possible cost in dollars and damage to the environment and the highway network.**





## WINTER OPERATIONS STRATEGIES

- **Anti-icing** is a proactive winter strategy of preventing snow or ice from bonding to the pavement.
- **De-icing** is traditional reactive winter maintenance strategy of breaking the snow/ice and pavement bond once formed.
- **Both strategies are critical** and play roles in SHA's snow and ice control operations.

# ANTI-ICING OPERATIONS

- Anti-icing involves a timely application of pre-wetted salt or liquid chemicals to the roadways prior to any precipitation.





## ANTI-ICING OPERATIONS

- **Anti-icing helps SHA maintain highways in the best condition possible throughout a storm.**
- **Anti-icing lessens the likelihood of snowpack.**
- **Anti-icing increases traffic safety at a lower cost.**
- **Anti-icing helps limit damage to the environment.**





## DE-ICING OPERATIONS

- **De-icing operations require large amounts of salt/liquid de-icer to work through snowpack and break the pavement bond.**
- **De-icing results in higher safety costs due to delays in achieving bare pavement.**
- **De-icing leads to more damage to the environment and highway system.**





## USING SOLID MATERIAL

- **For proper operation, spreader systems need to be calibrated yearly, at a minimum.**
- **At the beginning of a storm, the initial salt application should be made as soon as snow or ice begins to accumulate on the pavement.**
- **The prevention or breaking of the snow bond to the road is the primary reason for applying salt in a snowstorm.**
- **Salt produces a brine solution that keeps snow and ice from bonding to the pavement.**



## USING SOLID MATERIAL

- **A well-trained operator knows when to apply salt, and when not to.**
- **The main idea in a storm is to use no more salt than is necessary to correct the condition at hand.**
- **Using more salt than necessary to correct the condition will work against you and it damages the environment.**



# SAFETY

- **Snowstorms are the number one hazard to traffic on our roadways.**
- **Snow removal equipment is the number two hazard to traffic.**
- **The number two cause of accidents was found to be the snowplow attached to the dump truck.**





# SAFETY

- **Remove the plow after completing snow removal operations.**
- **Remove the plow frame or lower the lift arm to reduce the potential hazard to other vehicles.**
- **It is never a safe practice to back up a dump truck.**



# SAFETY

- **Backing during a snowstorm is just asking for trouble.**
- **Watch for overhead obstructions during salt spreading operations when raising the dump bed.**
- **The higher the dump bed is raised, the more likely the truck is to tip over.**



# SAFETY

- **The higher the truck bed, the lower the truck's speed should be.**
- **SHA plow trucks are not authorized emergency vehicles; however, SHA plow trucks are required to clean out emergency access points.**
- **Operators must obey the same rules as any other vehicle on the road.**





## TERMS AND DEFINITIONS

- **You can refer to the Roadway Winter Operations Course Manual, Section 2, for multiple terms and definitions used throughout this presentation.**





# GENERAL KNOWLEDGE

## ROADWAY PLOWING

- **Operator's knowledge must include the preventive maintenance (PM) of a dump truck and any related pieces of equipment.**
- **How to mount the various types of plows, salt box, and spinner.**



## ROADWAY PLOWING

- **The operation of the plow, salt box, saddle tank, and spinner.**
- **Maneuver a truck around obstacles with a plow mounted.**



## TROUBLE SHOOTING

- **Keep an eye on your plow blade for wear and replace when needed.**
- **Store extra plow pins in truck.**
- **Keep all truck lights free of snow and ice.**
- **Keep radiator grill from obstructions to prevent engine overheating.**





## TROUBLE SHOOTING

- **Carry spare fuses and bulbs.**
- **Carry windshield cleaner and an ice scraper.**
- **Be familiar with the type and size of hoses for replacement.**



## TROUBLE SHOOTING

- **Know which hydraulic coupling controls what function.**
- **Carry a quick link for repairing a broken chain.**



## **PRE-SEASON PREPARATION MEETING**

- **Have a meeting with all personnel involved in snow removal operations before the winter begins.**
- **Personnel involved are shop personnel, route supervisors, contractors, and EOC representative.**



# PRE-SEASON PREPARATION MEETING

## **Some topics that should be covered:**

- **Route assignments**
- **Truck assignments (state/contract)**
- **Roadway/Snow hazards**
- **Turn around points**
- **Changes in traffic patterns**



# ROADWAY HAZARDS

Always be alert to obstructions to your plowing.



**Expansion Joints**



**Offset Curbs**

# ROADWAY HAZARDS



**Manhole Covers**



**Steel Plates**



# ROADWAY HAZARDS



- **Cold Spots and Black Ice**
- **Low Shoulders / No shoulders**
- **Overhead obstructions - bridges, trees, wires**
- **And, of course, the traveling public**



## ROADWAY MARKING DEVICES

- **Delineating posts**
- **Stop bars**
- **Arrows**
- **Raised pavement markers**
- **Snow guide stakes**

# LOADING & UNLOADING SALT STORAGE STRUCTURES





## SALT DOME LOADING

- **Back through the dome entrance to fill both front sides.**
- **Go forward to fill both sides and the rear of dome.**
- **Fill in the center to equal height.**





## SALT DOME LOADING

- **Build a ramp inside of dome.**
- **Level off top of pile.**
- **Repeat process over again.**
- **Fill in the ramp from the back wall to entrance after reaching desired height.**





## SALT DOME UNLOADING

- **Remove salt from the entire face of salt pile.**
- **Never dig a straight narrow path into a salt pile.**

# SALT BARN LOADING

**Very little loader articulation is needed to load a barn design.**





## SALT BARN LOADING

**A longer ramp with less incline is needed to load barn.**







## SALT BARN LOADING

**Salt must still be kept below the maximum salt height line.**





## PRE-STORM PREPARATION EQUIPMENT CHECKS

- Match plow number to truck number.
- Mount plow frame and plow to truck.
- Load truck bed with salt, aggregates, sand, or mixture. **Check with your managers ahead of time to see what is permitted in your region.**
- Cover the load.





# SALT BOX INSTALLATION AND MAINTENANCE



# SALT BOX INSTALLATION

## Hinge installation

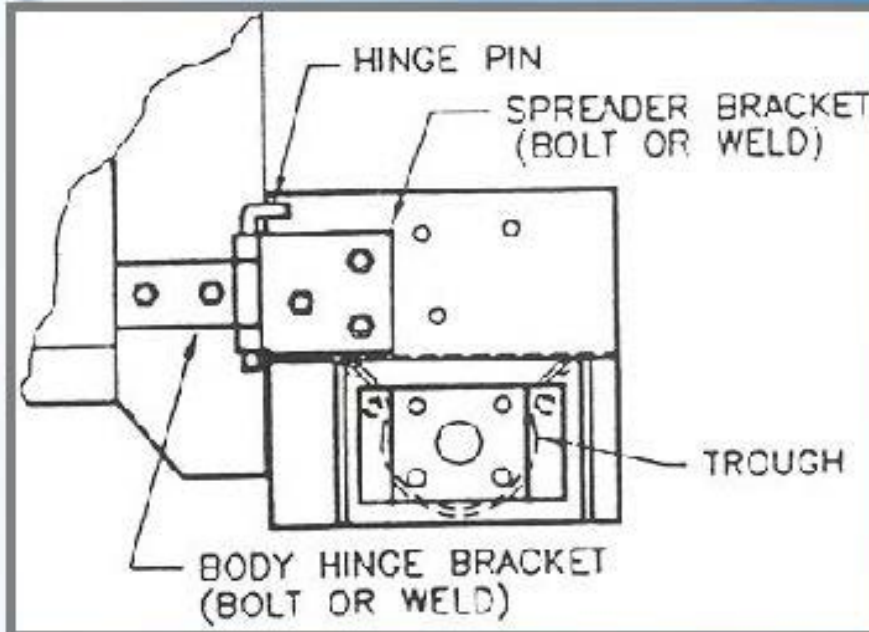

## Strap installation

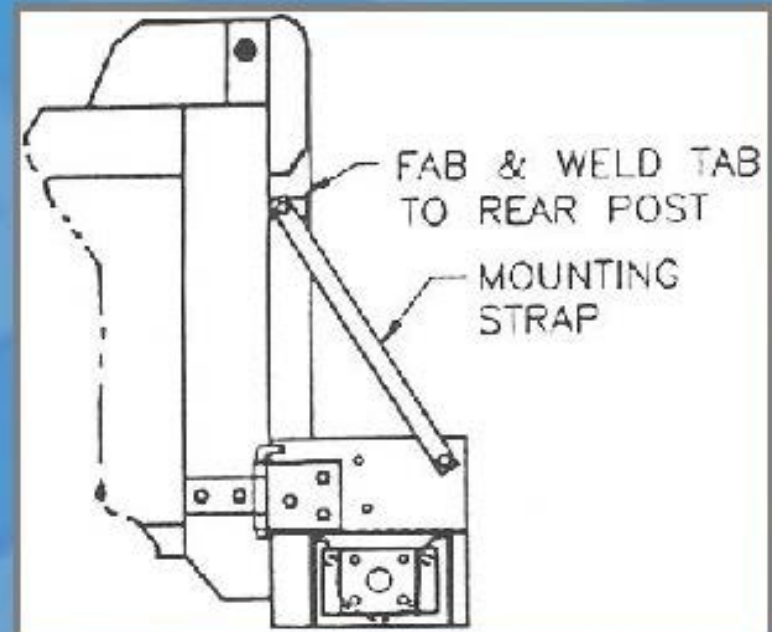



# SALT BOX MAINTENANCE

**Check oil level in Auger motor.**







## SALT BOX MAINTENANCE

**Lubricate the Auger End  
Bearing at the beginning of  
each shift.**





# SALT BOX MAINTENANCE

**Clean spreader after each storm.**





# SALT SPREADER SYSTEMS

## DICKEY - JOHN

### DjGC15



# SALT SPREADER SYSTEMS

## DICKEY - JOHN ICS2000



# SALT SPREADER SYSTEMS DICKEY - JOHN CONTROL POINT





# SALT SPREADER SYSTEMS

## FORCE AMERICA SSC5100 SPREADER CONTROL



# SALT SPREADER SYSTEMS

## FORCE AMERICA SSC6100 SPREADER CONTROL







# ROADWAYS AND SURFACES

## TWO-LANE ROADWAYS



**One 12 foot wide lane traveling in each direction.**

**The standard plow angled correctly will clear  
8 to 9 feet per pass.**



# ROADWAYS AND SURFACES

## TWO-LANE ROADWAYS



**Four passes needed to clear the entire road.**

**Clear road shoulders.**

# MULTI-LANE HIGHWAYS



**Multiple lanes traveling in both directions.**

**Road width determines the number of plow trucks needed.**



# MULTI-LANE HIGHWAYS



**Factors considered are the median width, shoulders and Jersey barriers.**

**When possible, begin plowing before rush hour traffic.**



## ASPHALT ROAD SURFACE

- **An asphalt road surface has a crown in the center to aid in run-off.**
- **Super-elevated curves have a high side.**
- **Always keep in mind how these roadway features respond to salting operations.**





## CONCRETE ROAD SURFACE

- **Reinforced concrete has a contraction joint every 40 feet.**
- **Reinforced concrete has an expansion joint every 600 feet.**
- **Bridges have expansion joints at both ends and may have an expansion dam near the middle of the bridge.**



## ROADWAY CONFIGURATIONS INTERSECTIONS

- **Empty your plow before crossing intersections.**
- **Reduce the size of the windrow.**
- **Avoid building snowbanks that interfere with sight distance.**
- **Keep traffic signs unobstructed from view.**



## RAMPS AND CURVES

- **Plow ramps and curves from the high side to the low side.**
- **Spread salt on the high side of ramps and curves.**
- **Keep your speed down on all ramps and curves.**





## BRIDGES AND OVERPASSES

- **Bridge surface may be higher than the road surface due to the bridge freezing and expanding.**
- **Care must be taken not to throw snow over the bridge to the road below.**
- **Keep the sidewalks on bridges open for pedestrians.**

## SHOULDERS, MEDIANS & JERSEY BARRIERS



- **Plow away from medians with minimum width shoulder and barrier wall.**
- **Avoid plowing snow against a Jersey barrier.**
- **This creates a ramp for vehicles to launch to the other side.**





## MOUNTAINS AND HILLS

- **Traction is limited on hills.**
- **Stopping can be difficult on hills.**
- **Watch for melted snow refreezing in the road valley.**



## RAILROAD CROSSINGS

- **Avoid piling snow against signals, switch boxes, signs, etc.**
- **Raise plows slightly when crossing railroad tracks.**



## TYPES OF PLOWS

### - THE ONE-WAY PLOW -

- **One-way reversible plow (manual adjust).**
- **One-way reversible plow (hydraulic adjust).**
- **One-way non-reversible plow.**
- **Wing plow.**

## V - PLOW



**V-Plows are mounted to a Grader or Oshkosh.**



## V - PLOW



**Plows in both directions at the same time.**

**Also known as the “Drift Buster”.**





# **PLOWING TIPS AND TECHNIQUES**

## **- PLOWING SPEED -**

- **Keep your speed fast enough to move the snow away from the roadway...**
- **...but slow enough so the windrow does not cause property damage.**
- **The faster your speed the more unstable the truck.**



## PLOWING SPEED

- **Plowing too fast can create a blizzard-like condition that can obscure your vision.**
- **Reduce plowing speed at bridges.**
- **Reduce your left shoulder plowing speed when Jersey barriers located in the median.**

## PLOWING SPEED

**When part of a plow train, continually adjust your speed to maintain a good, even spacing between trucks.**

**The lead truck is in control of the plow train's speed.**

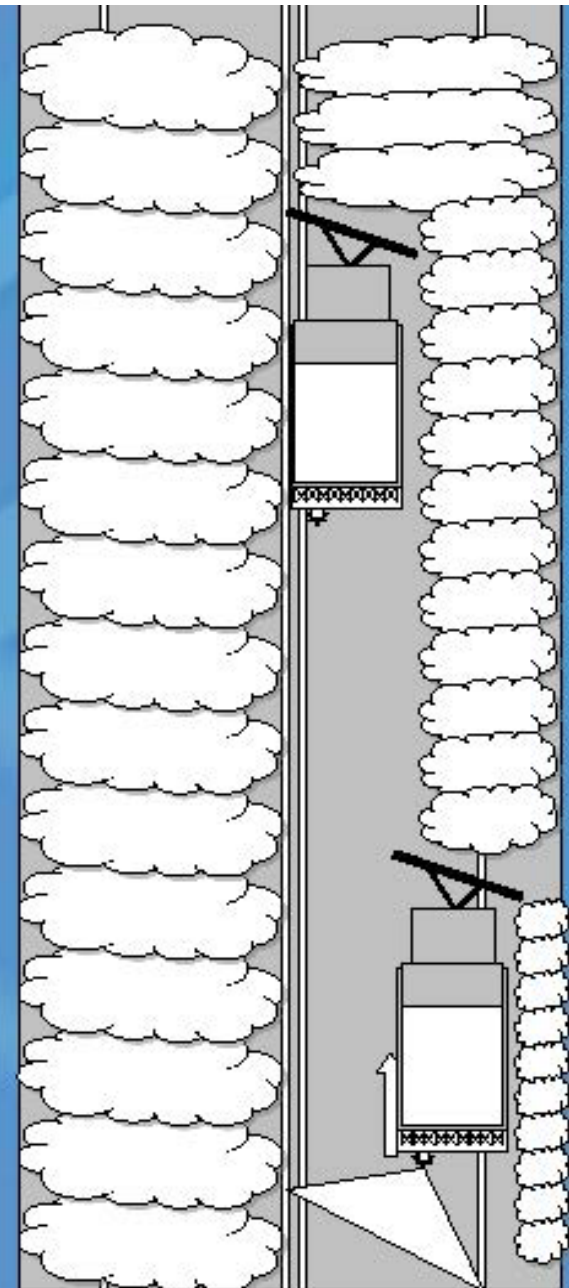





## POINTS TO REMEMBER

- **Always give bridges and ramps special attention.**
- **Salt the high sides of curves.**
- **Do not overuse salt.**
- **Use just enough to get the job done.**



## POINTS TO REMEMBER

- **Salt loses most of its effectiveness at temperatures below 20°F.**
- **Salt stops working altogether at - 6°F.**
- **Adding more salt to an already salted roadway can actually cause the brine solution to freeze.**





## POINTS TO REMEMBER

- **Salt mixed with liquid magnesium (80/20 blend) melts snow and ice down to minus 26° F.**
- **Maintain 300 to 500 pounds salt distribution per lane mile.**
- **Do not use “Manual”, “Stationary Unload”, or “Blast” unless absolutely necessary.**

## POINTS TO REMEMBER

- **Use the left spinner setting when spreading salt on two lane flat roadways.**

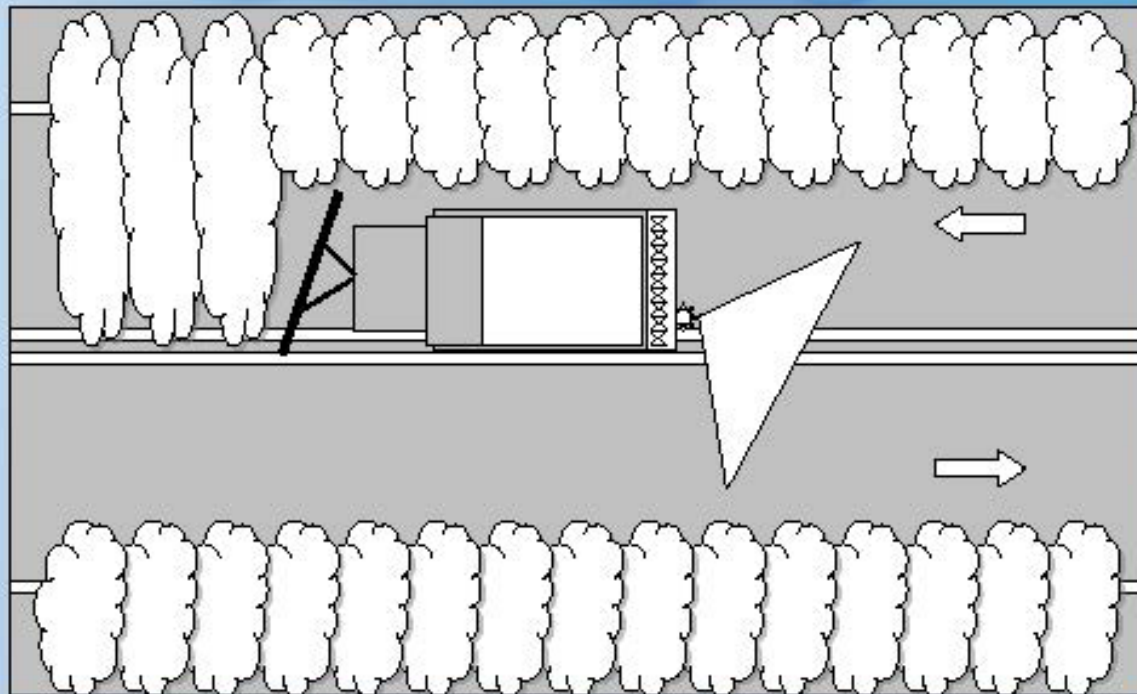



## POINTS TO REMEMBER



- **Spread salt on high side of banked curves.**
- **Adjust spinner setting to correct for wind velocity and direction.**





## PLOWING TIPS

- **Never drive faster than the posted speed limit.**
- **Use a lower gear than normal driving.**
- **Use extra care plowing curves.**
- **Plow with direction of traffic.**



## PLOWING TIPS

- **Do not block radiator with plow when traveling.**
- **Plow from centerline out to shoulder.**
- **Plow towards low side of ramps or curves.**
- **Plow away from wind when possible.**





## PLOWING TIPS

- **Raise blade before making sharp turns.**
- **Don't leave windrow across an intersection.**
- **Know your turn around points.**
- **Refuel with meal breaks or reloading.**



## **SINGLE VEHICLE PLOWING**

**Plow lane in one direction  
and drop salt behind  
truck.**

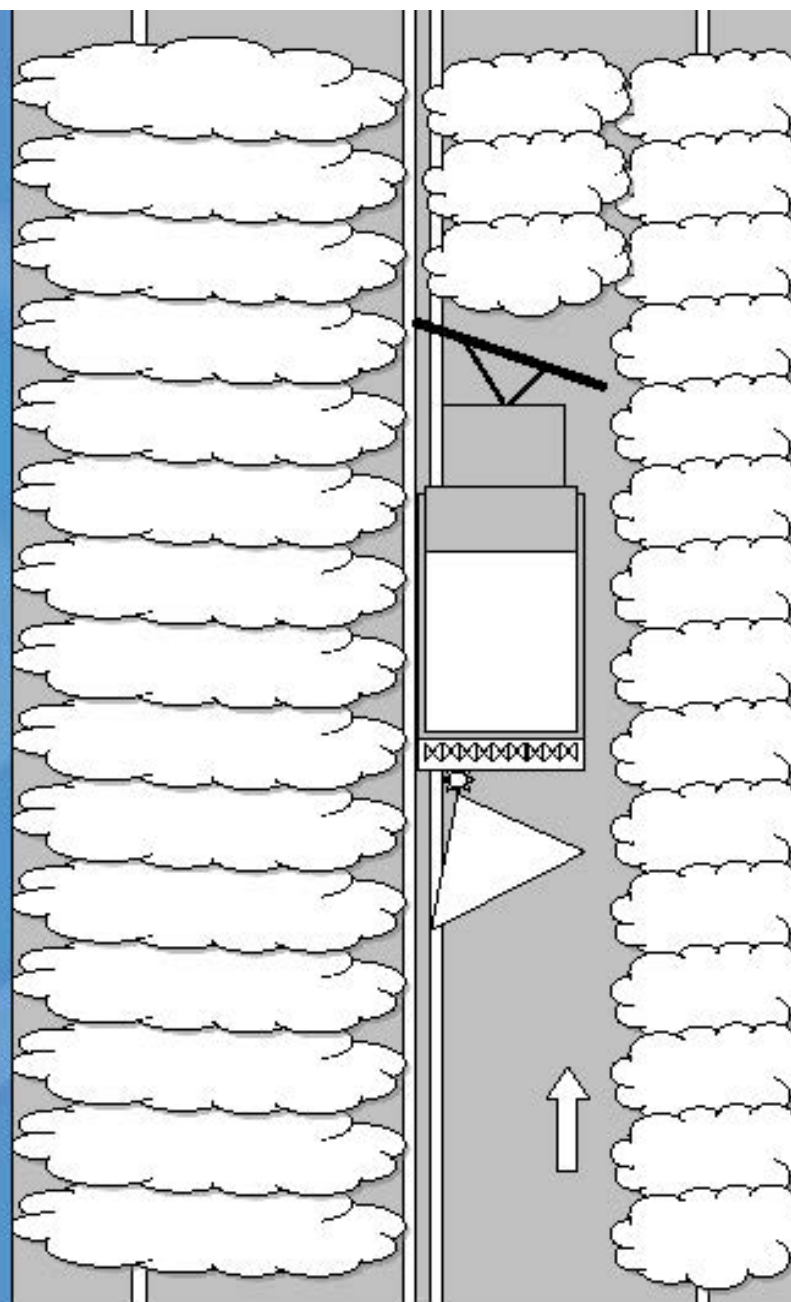



## **SINGLE VEHICLE PLOWING**

**Plow lane in one  
direction, turn at end  
of route, plow lane in  
opposite direction and  
salt both lanes.**

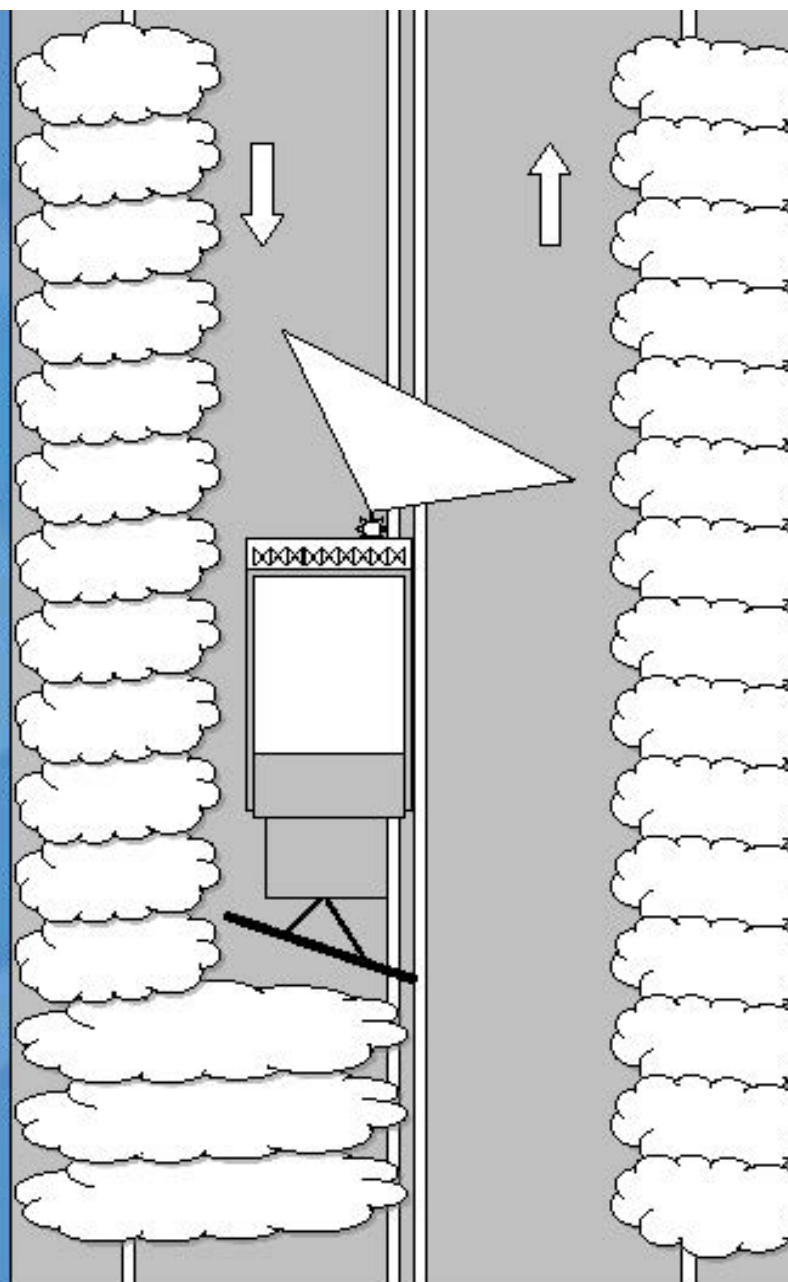





## MULTI-VEHICLE PLOWING

- **The width of the road determines how many plows are needed to clear the snow.**
- **Minimum overlap of any “plow train” should be about 1 foot.**
- **Distance between plow trucks should be around 150 feet.**



## MULTI-VEHICLE PLOWING

- The deeper the snow, the more overlap needed to avoid leaving a windrow.
- First truck clears 8 feet of the left traffic lane, leaving 4 feet for second truck.
- Second truck overlaps 1 foot clearing 4 feet of first lane and 3 feet of second lane, leaving 9 feet for third truck.

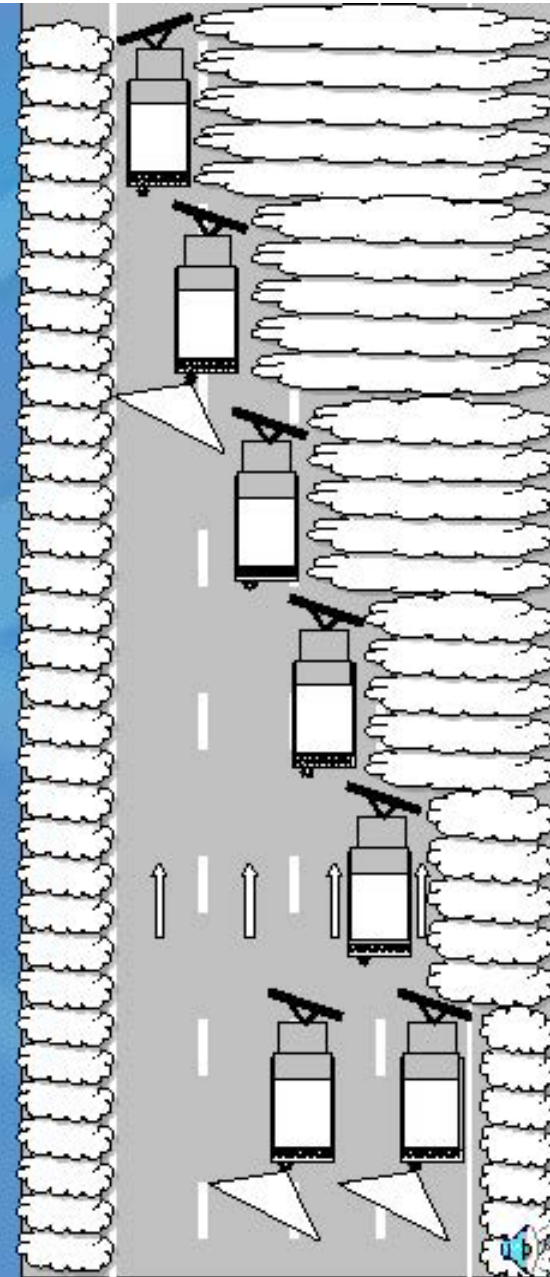

## MULTI-VEHICLE PLOWING

- **Third truck overlaps 1 foot clearing 7 feet of second lane, leaving 2 feet for fourth truck.**
- **Fourth truck overlaps 1 foot clearing 2 feet of second lane and 5 feet of shoulder.**
- **One more truck would be required if a third lane was present.**

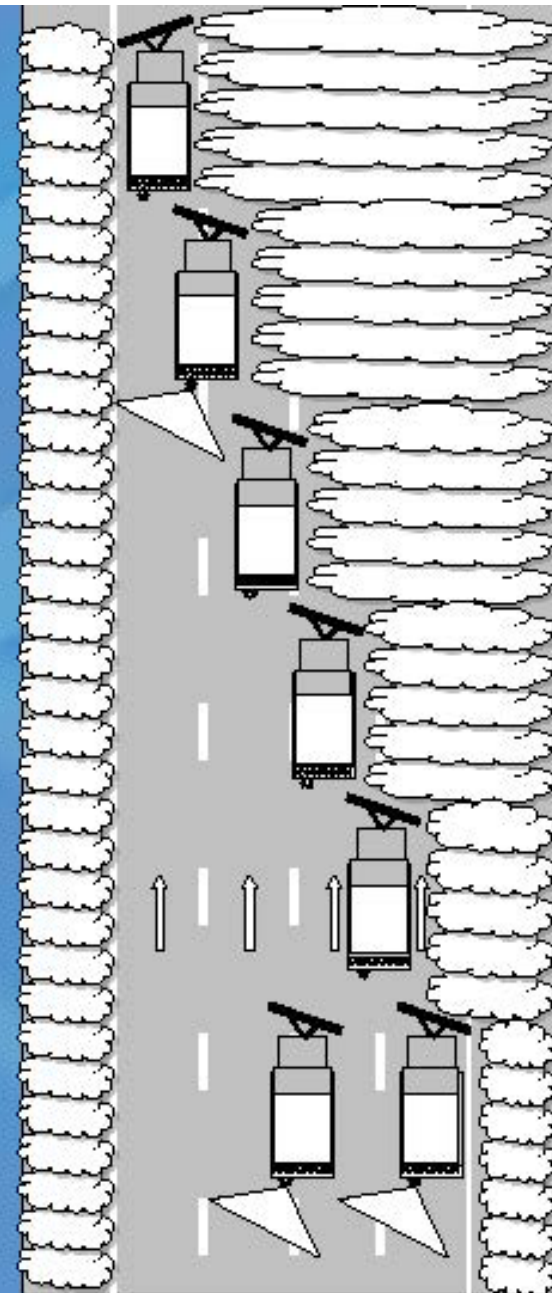





# MULTI-VEHICLE PLOWING

- **Four or more lanes would require more plow trucks.**
- **The larger trucks should be at the end of the train.**
- **The last truck plows ramps.**

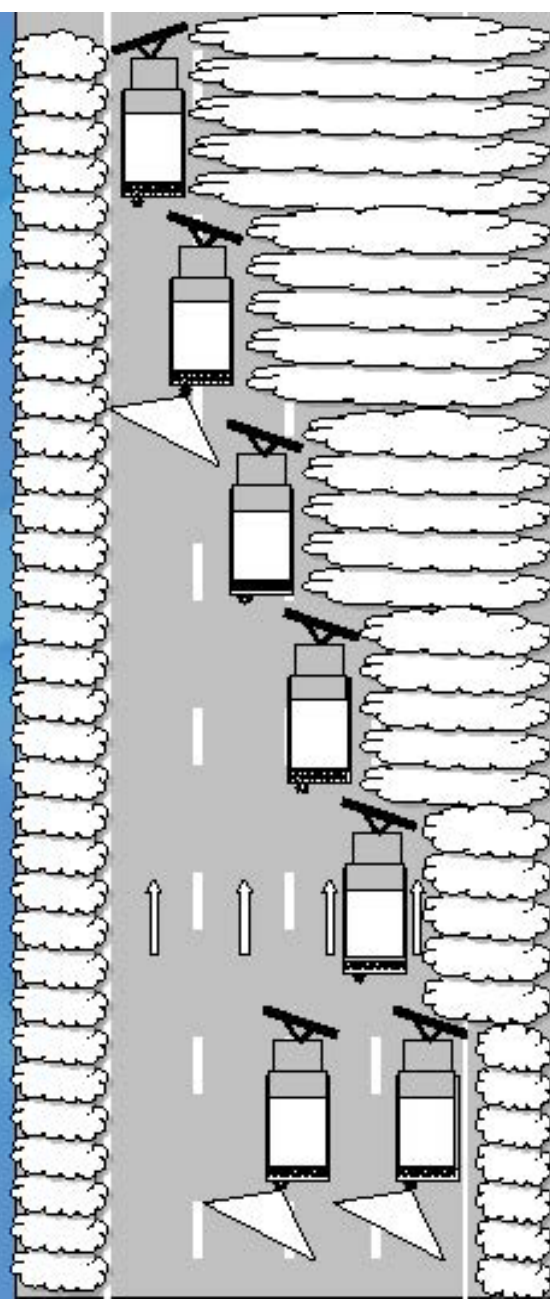



## TYPES OF SNOW AND PLOW ANGLE

- **Wet snow requires more plow angle to discharge snow from plow moldboard.**
- **Plow must still clear a path for the truck tires.**





## SADDLE TANK OPERATIONS

- **Keep saddle tank filled with salt brine or liquid magnesium during winter months.**
- **Spray liquid magnesium or salt brine on your salt load at the rate of 8-10 gallons per ton of salt.**
- **Use saddle tank when applying salt to dry snow.**



## SADDLE TANK OPERATIONS

- **Use saddle tank when pavement temperatures are 25°F or below.**
- **Use saddle tank to combat freezing rain, sleet, or black ice.**
- **Do not use saddle tank on slush or wet snow unless pavement temperatures are below 25°F.**

## LIQUID APPLICATOR TANK GUIDELINES



- **Apply salt brine 2 to 10 hours at a minimum before storm.**
- **Spray bridges and cold spots prior to cold weekends to prevent emergencies.**



## LIQUID APPLICATOR TANK GUIDELINES



- **Standard application rate of salt brine is 45 to 80 gallons per lane mile.**
- **See section 15 charts for correct application.**





**Now let's move on to  
Part II of the presentation.**

**Winter Operations  
Environmental  
Considerations**



# **SHA Snow College**

## **Winter Operations Environmental Considerations**

**Winter Materials Storage,  
Handling and Spreading**



**Before we get into this  
second part of the  
presentation, we need  
to ask you a few  
personal questions. OK?**



# How Many of You Like To Fish?





# How Many of You Like To Hunt?

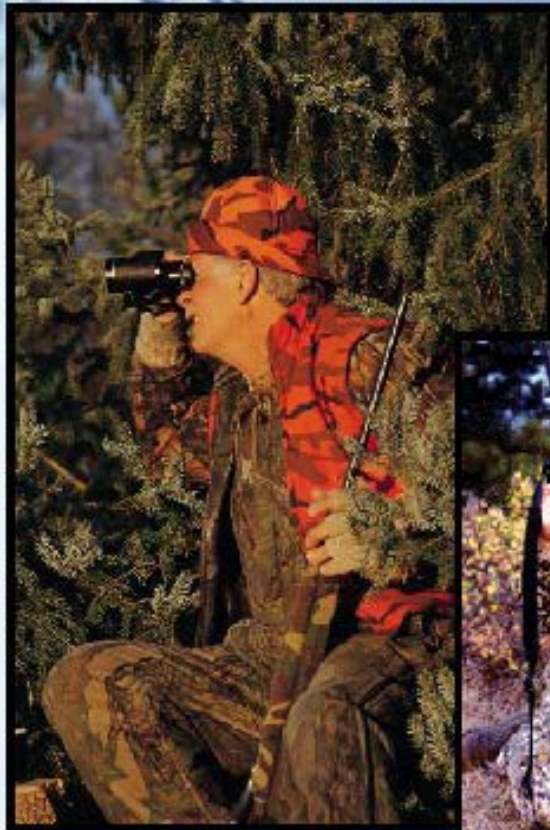

# How Many of You Like Being Around The Water?





# How Many of You Really, Really Like Being Around The Water?





# How Many of You Like to Camp, to Hike, Bird Watch or Bike?

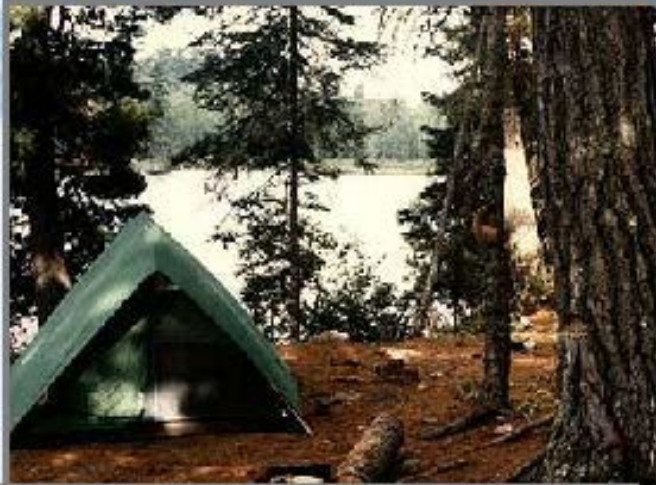



# How Many Just Like Nature?

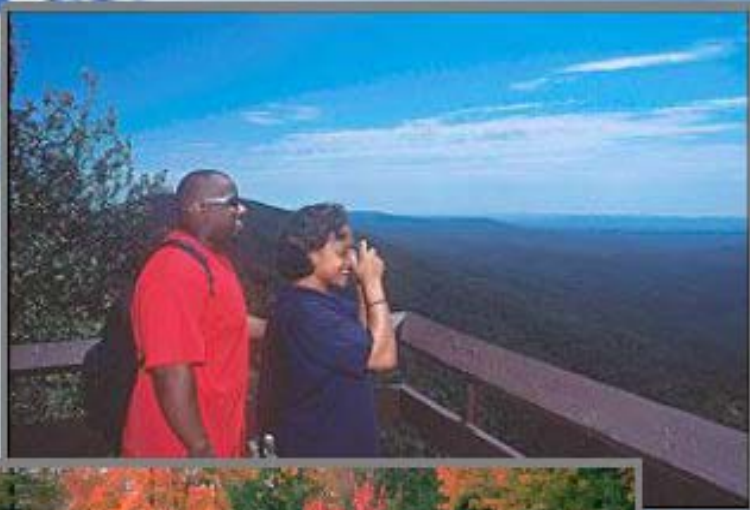

# How Many of You Like To Eat Steamed Crabs or Oysters From Our Chesapeake Bay?







**So, what does this have to do  
with Snow College you ask?**



**As SHA Employees  
you play an important role in  
protecting our environment  
during winter operations by  
“Salting Sensibly”.**





**What's the big deal – salt is a naturally occurring substance!**

**While salt is a naturally occurring substance, high concentrations of salt negatively affect or destroy land based and aquatic habitats and species.**



Once salt goes into solution (becomes a brine solution) it cannot be recovered. It is stored in soil or water and can reach levels that are considered contamination.

Salt can contaminate drinking water supplies in wells and in reservoirs, inhibit the establishment of vegetation or crops, and eliminate habitat for fish and other aquatic species.





**By implementing a few Best Management Practices (BMP's) in handling salt and other de-icing materials, water resources can be protected.**

**The BMP's, created by SHA, shall be applied to SHA's National Pollutant Discharge Elimination System (NPDES) Industrial and Municipal Permits. *These permits are issued by the Maryland Department of Environment.***

# Salt Storage



During the off-season, a barrier should be placed across the structure's opening to prevent salt from contaminating the environment.



# Salt Storage



Make sure when salt is delivered, that all inlets and drainage structures are protected, and all the salt is under covered storage by day's end. Here an inlet is protected by covering it with sheet signing, but overnight rain-washed dissolved salt into the drainage system discharging it off site.

# Abrasive Storage



Abrasives stored under cover. Here the material is far enough away from opening that it does not need a barrier across the opening.



# Brine and/or MgCl Storage



Inspect tanks monthly paying particular attention to valves and fittings. Place drip pan under leaks and repair immediately.



# Salt Handling

- **During winter storm events, mixing salt and abrasives on impervious surfaces is allowable, dependent on region.**
- **Uncovered salt/abrasive stockpiles are allowed during a storm event; however, they must be placed under cover immediately after plowing operations have stopped and the mixing area must then be free of any residual salt and/or abrasives.**



# Salt Handling



Impact of a salt/abrasive mix not being placed under cover. Non-compliant with NPDES permit conditions.



# Salt Handling



Mixing salt/abrasives on unpaved areas can result in destroying vegetation and causing an erosion problem.

# Salt Handling



To minimize spillage do not overfill trucks with salt or salt/abrasive mix. Upon completion of plowing event, all material on macadam (pavement) lot must be swept and returned to covered storage.



# Salt Handling



Upon completion of plowing, return all unused salt to covered salt storage area.

Dumping residual salt in this area killed the vegetation and the area was at risk for erosion. This area had to be restored by removing contaminated soil, backfilling and seeding and mulching.





# Materials Spreading

To provide bare pavement in a cost-effective and environmentally responsible manner:

- Use appropriate shop application rates to match specific storm conditions.
- Unless otherwise directed, only apply salt to your designated route.
- Return unused salt to designated dome or barn. Never spread salt just to get rid of it.



# Materials Spreading

By following appropriate Salt Spreading Guidelines, you will be performing your job duties in an environmentally sensitive manner, reducing the amounts of material discharging from the roadway into the natural environment.

Remember - Excess salt run-off not only impacts aquatic habitat but also impacts drinking water in wells and reservoirs.

# Materials Spreading



Keep your load covered. Use the tarp to reduce wind erosion of material



## Equipment Preparation and Cleaning



At a minimum, prior to winter maintenance season, calibrate equipment to ensure maximum efficiency and proper application rates.



## Equipment Preparation and Cleaning



Check all fluid systems for leaks to reduce the risk of discharge of petroleum-based products on roadways and macadam (paved) lots.

## Equipment Preparation and Cleaning



Clean equipment in wash bay so that wash water is treated by the grit separator and oil/water separator to minimize the discharge of sediment, salt and heavy metals into the environment.



**Do your part in helping to  
protect the environment.**

**Be an Environmental Steward.**

**Salt Sensibly.**





## Total Daily Maximum Load (TMDL)

- Governs the amounts of specific pollutants discharged into streams, watersheds, rivers, ponds, lakes and other bodies of water that are “impaired waterways” under the authority of the US environmental Protection Agency and Maryland Department of the Environment





## Total Daily Maximum Load (TMDL)

Impaired waterways are those that have been adversely impacted by pollutants to the point that biological functions have been negatively impacted and/or diminished whereby habitat is marginal or non-existent and/or drinking water has been contaminated.



**That's the end of day one.**

**Thank you for your attention.**

**Created by:  
Scott K. Simons, Office of  
Maintenance**

**and the**

**Maintenance Training &  
Certification Team**

## 17 Appendix C: OOM Winter Town Meeting



# OOM WINTER TOWN MEETING 2023

Office of Maintenance

Scott Simons

and

Sandi Sauter



# HIGHWAY ASSETS

---

- 28 Maintenance Shops in 7 Districts
- 17,417 Lane Miles
- 5,212 Centerline Miles
- 37.1 Billion Annual Vehicle Miles of Travel
- Annual Average Daily Traffic
  - 50,000+: 3,048 Lane Miles (17%)
  - 10,000-49,999: 7,484 Lane Miles (43%)
  - <9,999: 6,885 Lane Miles (40%)

# WINTER RESOURCES

---

- ~1,100 Maintenance Shop Employees
  - ~760 Field Employees (173 since last November)
  - ~110 Managers
  - ~190 Administrative Staff and Mechanics
  - ~40 Winter Volunteers
- ~600 MDOT SHA Dump Trucks
- ~2,700 Pieces of Hired Equipment
- \$80 Million Winter Budget
  - ~\$35.8 million in expenditures this past season
- ~385,000 tons Rock Salt
- ~1.7 million gallons Salt Brine

# SALT USAGE

---

- Achieved a 9% statewide reduction from the previous season
- This was a significant accomplishment considering the record low frozen precipitation totals
- However, there is still room for improvement moving forward
  - utilize training
  - sound logic
  - good decision making

# 2022/2023 SALT USAGE STATISTICS

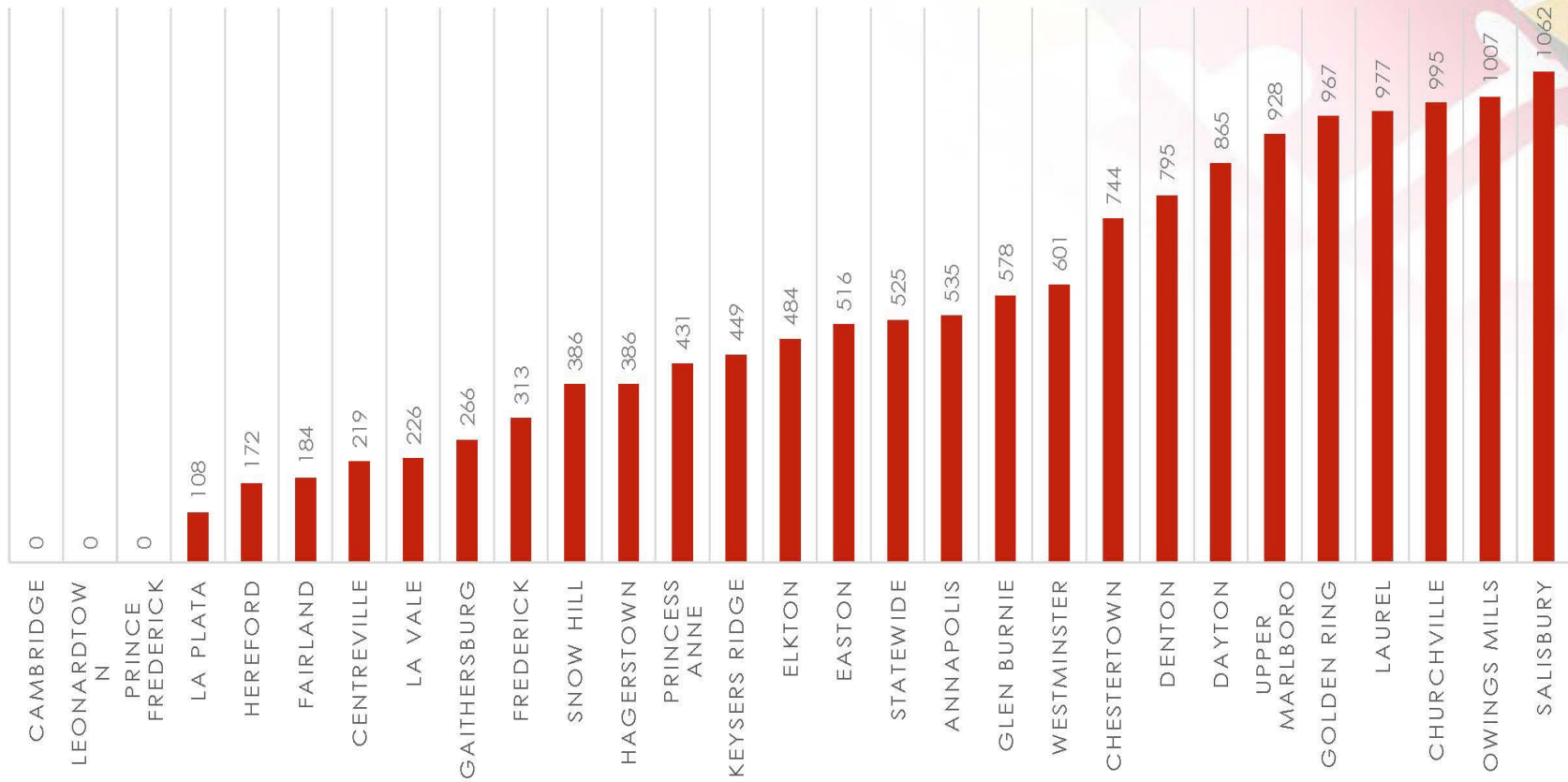



# EUTECTIC CURVE SIMPLIFIED

## Understanding Salt Brine Concentration

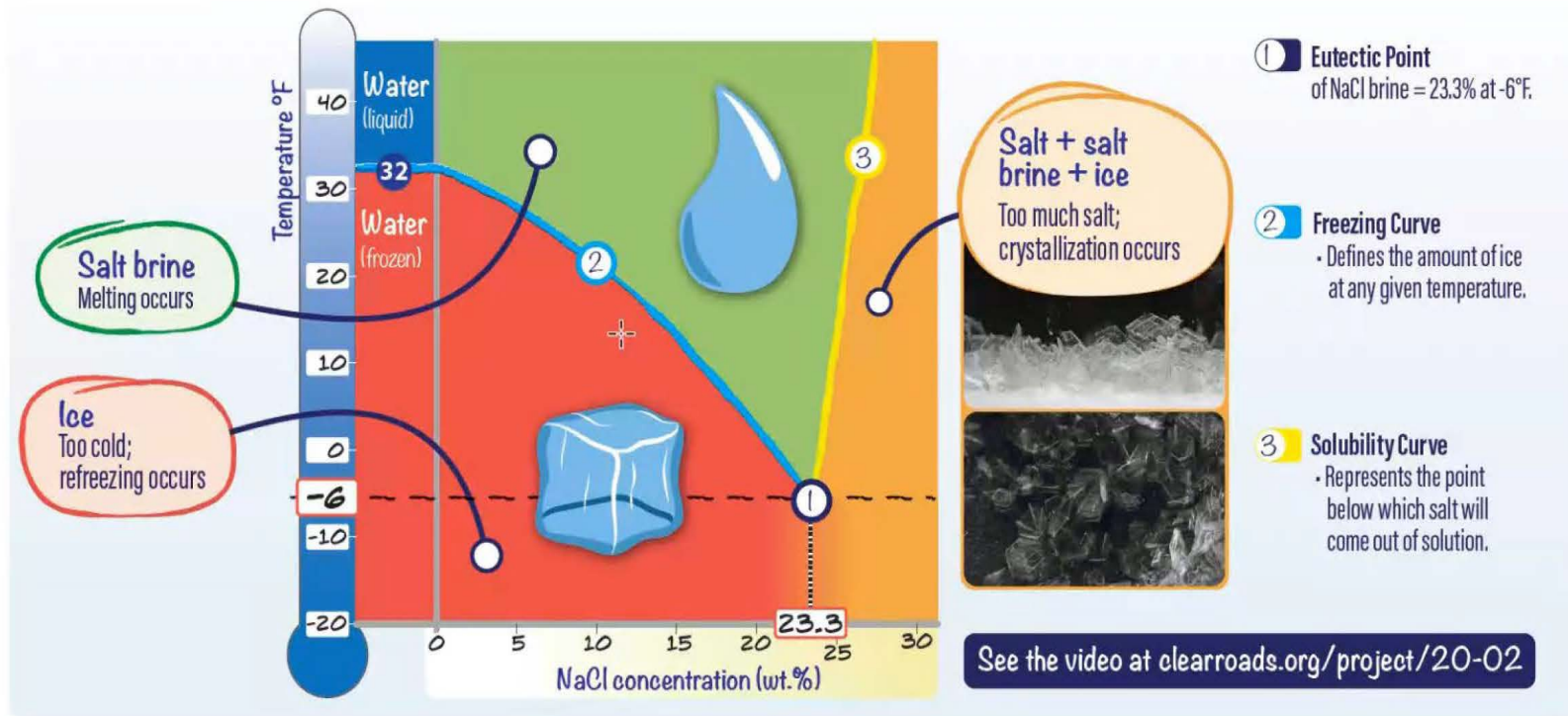

# NEW AVL CAPABILITIES

---

- New AVL Provider – Geo-Tab
- Able to check each route for:
  - route completion
  - placement of resources
  - route decay
- MARWIS Integration
  - real time route condition reporting w/overlap
  - better resource allocation to areas needing service
- Operational Equipment Data
  - track and respond to equipment issues and failures

# ICE ACCUMULATION TOTALS

- District Wide Ice Accumulation totals for 2022/2023
- Any sleet data isn't factored into this as it was captured as snow data.

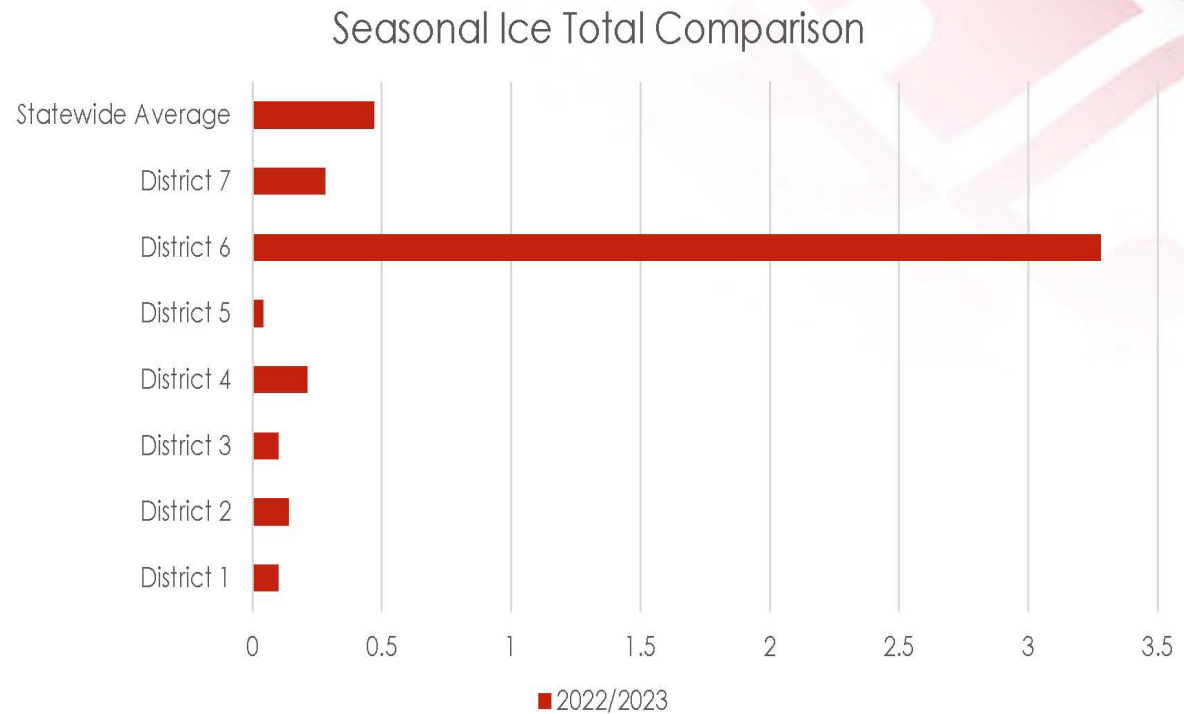

# SLEET STORM SALT USAGE



Metro lot  
after the  
event

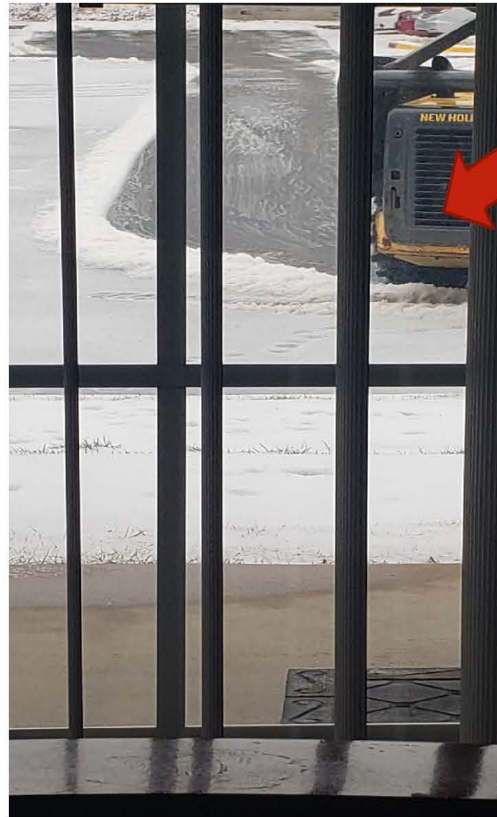

Sleet that  
looks like  
snow

Metro lot  
after the  
event

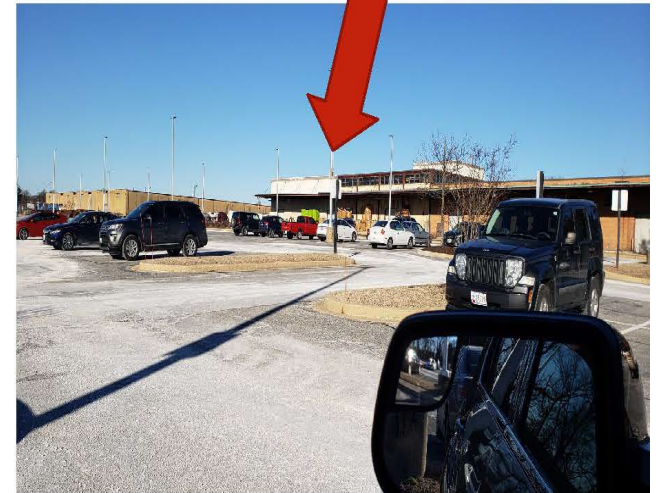



# WINTER CONTRACTOR PROCEDURES

---

- Electronic Invoicing
  - email address is now required for invoice submission
- One on One Appointments for Contract Paperwork Submittal
- Staggered Equipment Inspections
  - v-box spreaders will be inspected this season

# WINTER CONTRACTOR PROCEDURES

---

- Pre-Winter Contractor Meeting
  - will not take place
  - power-point presentation available via link in contract
- Not Permitted in MDOT SHA Buildings
  - same as last season
- Outside Check-In/Check-Out
  - drive-up windows
  - AVL distribution at the beginning of winter season during pre-winter inspection

# NEW HIRES SINCE 11/1/2019

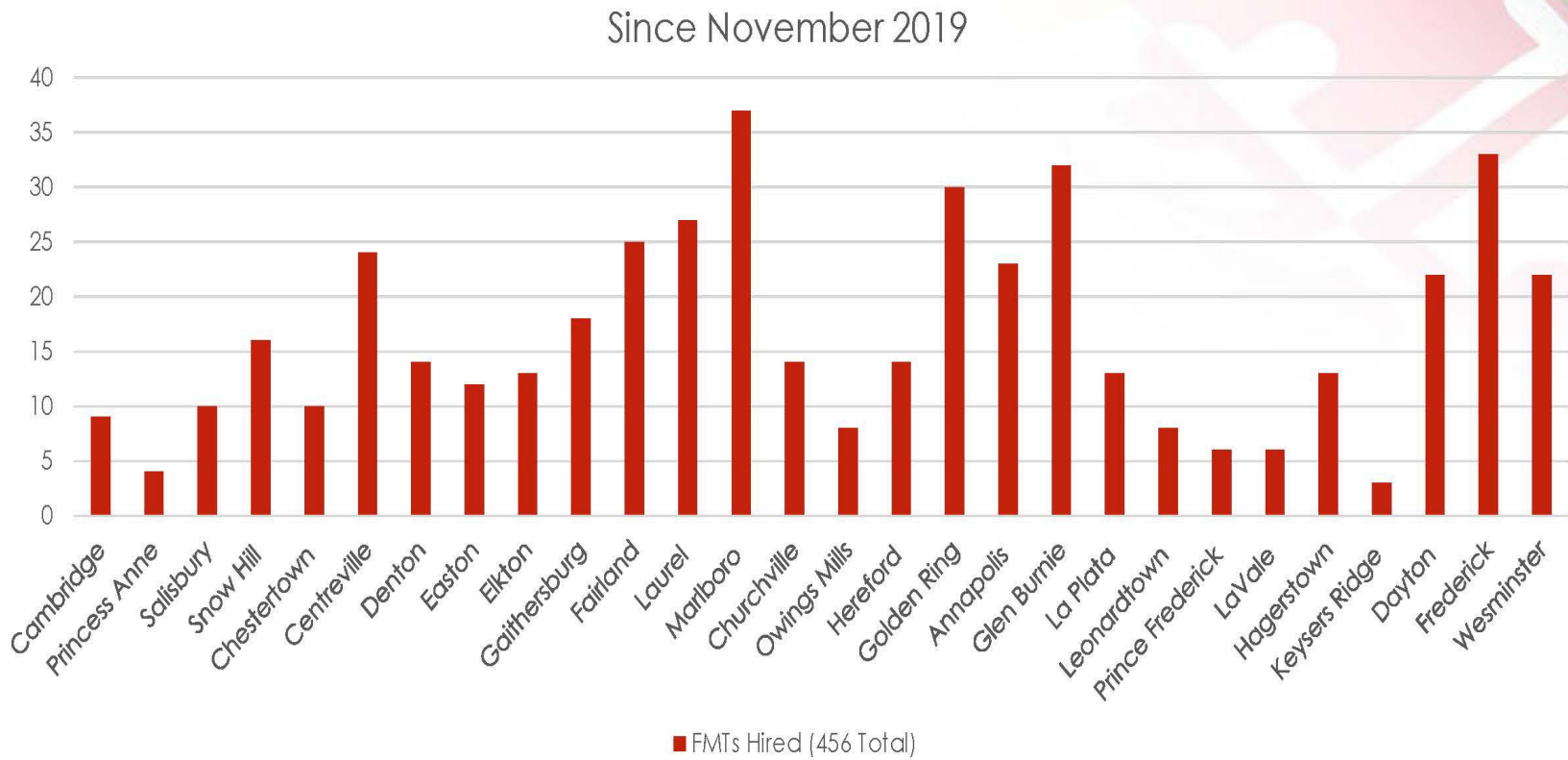

# KNOWLEDGE TRANSFER

---

- Where are newer operators?
- What is a salt usage rate?
- How many can tell me how much salt to put down?
- Do you know when to start salting a road?
- How fast is too fast to be traveling when salting?
- Does salt always work the same?
- Should you plow/salt the high side or low side of a ramp first?
- At what temperature does salt start to lose its effectiveness?
- What else can anyone in this room offer?



# PASSING THE TORCH



- I am one simple guy who does this once a year
- Some of you veterans may not be here next winter
- Knowledge transfer is a must for success
- A lot of new operators were certified in the last year and half
- Seasoned winter veterans take some of the new employees under your guidance
- Remember back to when you were the new person

TIME TO PUSH!!! (AND SALT AS NEEDED)

---



**MOT** MARYLAND DEPARTMENT OF TRANSPORTATION  
STATE HIGHWAY ADMINISTRATION