

Bridge Railing Manual



**STATE HIGHWAY
ADMINISTRATION**

Table of Contents

Chapter 1 Introduction	1-1
1.1 Crashworthy Requirements	1-1
1.2 Barrier Strength Selection.....	1-2
1.3 Bridge Rail Limits.....	1-3
Chapter 2 Design Considerations	2-1
2.1 Bridge Users	2-1
2.2 Bridge Railing Applications.....	2-1
2.3 Bridge Rail Ends.....	2-4
2.4 Fencing	2-6
2.4.1 Fencing Locations.....	2-6
2.4.2 Fence Post Spacing.....	2-7
2.5 Bridge Rails on Retaining Walls.....	2-7
2.6 Bridge Rail Selection Coordination	2-9
2.7 Existing Structures.....	2-9
Chapter 3 Bridge Rail Selection	3-1
3.1 MDOT SHA Standard Bridge Rails	3-1
3.2 Use of Non-Standard MDOT SHA Bridge Rails.....	3-7
Chapter 4 Temporary Barriers	4-1
4.1 Design Considerations.....	4-1
4.2 MDOT SHA Standard Low Deflection Applications	4-3

Chapter 1 Introduction

The Maryland Department of Transportation has developed this *Bridge Railing Manual* to document national policy and practice and to emphasize standards and practices that have proven successful in this state. This manual applies to all Maryland Department of Transportation State Highway Administration (MDOT SHA) administered contracts as well as all contracts receiving federal funding through MDOT SHA. This manual incorporates guidance that is currently found in the following National publications and references:

- The 2018 AASHTO A Policy on Geometric Design of Highways and Streets;
- The 2016 AASHTO Manual for Assessing Safety Hardware;
- The 2011 AASHTO Roadside Design Guide;
- The 2004 AASHTO Guide for the Planning, Design, and Operation of Pedestrian Facilities;
- The 2017 AASHTO LRFD Bridge Design Specifications;
- Various Research Reports; and
- Guidance contained in memos and letters published by the FHWA.

As this manual is applied throughout the design process, it is critical for the designer to always be cognizant and to actively consider the principles of the forgiving roadside environment. The forgiving roadside environment concept was first introduced by AASHTO in 1974 in the second edition of their *Highway Design and Operational Practices Related Highway Safety Manual*. The two most important principles of the forgiving roadside environment that apply to this manual are as follows:

1. Provide errant vehicle with an opportunity to regain control before striking a fixed object along the roadside.
2. The traffic barrier which is installed to shield an obstruction must be less hazardous than the obstruction which it is meant to protect.

In the context of creating a forgiving roadside, The AASHTO *Roadside Design Guide* documents an order of preference for reducing roadside obstacles as follows:

1. Remove the obstacle.
2. Redesign the obstacle so it can be safely traversed.
3. Relocate the obstacle to a point where it is less likely to be struck.
4. Reduce the impact severity by using an appropriate breakaway device.
5. Shield the obstacle with a longitudinal traffic barrier designed for redirection or use a crash cushion.
6. Delineate the obstacle if the previous alternatives are not appropriate.

1.1 Crashworthy Requirements

All traffic railings that are constructed on MDOT SHA administered contracts as well as all contracts receiving federal funding through MDOT SHA shall be structurally and geometrically crashworthy for the application in which they are applied. In addition, the traffic barrier system must either be transitioned to an acceptable highway approach traffic barrier or continued to a point where it can be safely terminated off the structure.

Roadside safety first came into focus in the 1960s. The first documented procedures for full-scale vehicle crash testing were contained in *Highway Research Correlation Services Circular 482* which was a one-page paper published in 1962. In an August 28th, 1986 memo, the Federal Highway Administration (FHWA)

issued a policy requiring that all bridge rails that are used on the National Highway System (NHS) or the Interstate Highway System (IHS) must be crash tested. In the time since, crash testing procedures and guidelines as well as FHWA requirements and policies have changed multiple times, however, the importance of crash testing has remained a constant.

In 2009, AASHTO published the *Manual for Assessing Safety Hardware* (MASH) which superseded NCHRP Report 350 *Recommended Procedure for Safety Performance Evaluation of Highway Features* as the guidelines for roadside safety hardware performance evaluation. In 2016, AASHTO published the second edition of the MASH manual as well as agreed to a joint implementation agreement with the FHWA. The joint implementation agreement outlined the sunset dates for NCHRP Report 350 compliant roadside safety hardware and the sunrise dates for MASH 2016 compliant roadside safety hardware for work performed on the NHS. The January 7th, 2016 agreement stated that all “bridge rails, transitions, all other longitudinal barrier (including portable barriers installed permanently), all other terminals, sign supports, and all other breakaway hardware” would be MASH 2016 compliant for contracts let after December 31st, 2019.

On May 26, 2017, the FHWA issued an open letter to the states which stated that “The FHWA’s Federal-aid eligibility letters are provided as a service to the States and are not a requirement for roadside safety hardware to be eligible for federal-aid reimbursement.” This letter also went on to state, “Since its official launch questions about the AASHTO MASH criteria have been identified by a range of stakeholders. Until such time these questions are answered and the transportation community has more experience with AASHTO MASH requirements, FHWA will require manufacturers and States to run all AASHTO MASH recommended crash tests in order to qualify for a FHWA Federal-aid eligibility letter.” In addition, a letter from the FHWA to its Division Administrators issued on April 9, 2018 stated that “An eligibility letter is not a requirement for roadside safety hardware to be determined eligible for Federal funding. Roadside safety hardware is eligible for Federal funding if it has been determined to be crashworthy by the user agency (i.e. State DOT).” This manual is intended to document the bridge railings which are considered crashworthy by the Maryland Department of Transportation.

1.2 Barrier Strength Selection

The barrier application that is selected for installation should be selected based upon the Test Level (TL) criteria established in the latest edition of the MASH manual. The MASH manual currently defines six different Test Levels for longitudinal barriers. It is important to note that bridge rails are included in MASH’s longitudinal barrier designation. The recommended Test Matrices for longitudinal barriers are described in Figure 1-1.

Test Level	MASH Test No.	Test Vehicle	Impact Speed (mph)	Impact Angle (degrees)	Acceptable Impact Severity (kip-ft)
1	1-10	Passenger Car 2420-lb	31	25	≥13
	1-11	Pickup Truck 5000-lb	31	25	≥27
2	2-10	Passenger Car 2420-lb	44	25	≥25
	2-11	Pickup Truck 5000-lb	44	25	≥52
3	3-10	Passenger Car 2420-lb	62	25	≥51
	3-11	Pickup Truck 5000-lb	62	25	≥106
4	4-10	Passenger Car 2420-lb	62	25	≥51
	4-11	Pickup Truck 5000-lb	62	25	≥106
	4-12	Single-Unit Truck 22,000-lb	56	15	≥142
5	5-10	Passenger Car 2420-lb	62	25	≥51
	5-11	Pickup Truck 5000-lb	62	25	≥106
	5-12	Tractor-Van Trailer 79,300-lb	50	15	≥404
6	6-10	Passenger Car 2420-lb	62	25	≥51
	6-11	Pickup Truck 5000-lb	62	25	≥106
	6-12	Tractor-Tank Trailer 79,300-lb	50	15	≥404

Figure 1-1: MASH Test Matrix for Longitudinal Barriers

Figure 1-2 summarizes the guidance that the 2017 AASHTO LRFD Bridge Design Specifications, 8th Edition provides on selecting the appropriate Test Level criteria for a bridge rail application.

Test Level	AASHTO Guidance
TL-1	Taken to be generally acceptable for work zones with low posted speeds and very low-volume, low-speed local streets.
TL-2	Taken to be generally acceptable for work zones and most local and collector roads with favorable site conditions as well as where a small number of heavy vehicles is expected and posted speeds are reduced.
TL-3	Taken to be generally acceptable for a wide range of high-speed arterial highways with very low mixtures of heavy vehicles and with favorable site conditions.
TL-4	Taken to be generally acceptable for the majority of applications on high-speed highways, freeways, expressways, and Interstate highways with a mixture of trucks and heavy vehicles.
TL-5	Taken to be generally acceptable for the same applications as TL-4 and where large trucks make up a significant portion of the average daily traffic or when unfavorable site conditions justify a higher level of rail resistance.
TL-6	Taken to be generally acceptable for applications where tanker-type trucks or similar high center of gravity vehicles are anticipated, particularly along with unfavorable site conditions.

Figure 1-2: Test Level Selection Guidance

1.3 Bridge Rail Limits

All MDOT SHA administered contracts as well as all contracts receiving federal funding through MDOT SHA shall protect adjacent roadside hazards in accordance with the AASHTO *Roadside Design Guide* and with the guidance that is contained in this manual. For purposes of this manual, structures have been categorized into four different applications based upon how protection of adjacent hazards should be considered:

- **Bridges** – These structures are required to use bridge railing in accordance with this manual along the full length of the structure. MDOT SHA requires that all permanent bridge railing on high-speed roadways meet the requirements of a TL-5 bridge railing with the exception of locations where an open rail is desired for aesthetic purposes or where a TL-5 rail cannot be installed due to accelerated bridge construction techniques. At these exception locations on high-speed roadways, a TL-4 compliant bridge rail may be installed. For purposes of this discussion, a high-speed roadway is defined as any roadway where the higher of either the design speed or the posted speed is 50 mph and above. The bridge rail end as well as any other associated slopes which require protection should be protected as required by this manual and the AASHTO *Roadside Design Guide*.
- **Roadways elevated through use of retaining structures** – These structures require that bridge rail be installed along retaining walls where fall off protection is required. MDOT SHA requires that all permanent bridge railing on high-speed roadways meet the requirements of a TL-5 bridge railing with the exception of locations where an open rail is desired for aesthetic purposes or where a TL-5 rail cannot be installed due to accelerated bridge construction techniques. At these exception locations on high-speed roadways, a TL-4 compliant bridge rail may be installed. For purposes of this discussion, a high-speed roadway is defined as any roadway where the higher of either the design speed or the posted speed is 50 mph and above. Section 2.5 of this Manual provides information about the application of bridge rail along these elevated roadways. The bridge rail end, as well as any other associated slopes which require protection, should be protected as required by this manual and the AASHTO *Roadside Design Guide*.
- **Structures between 18'-6" and 40'-0"** – If geometrically feasible, these structures should provide bridge railing in accordance with this manual along the full length of the structure, however, on structures carrying very low mixtures of heavy vehicles and where the distance between the normal termination point of thrie beam on the approach and trail ends is between 18'-6" to 40'-0" the thrie beam can be carried across the entire parapet face. In these cases, the inside face of the concrete barrier shall be notched to receive the thrie beam so that its face is even with that of the face of the concrete barrier. Transition to W-beam traffic barrier off both ends of the barrier.
- **Buried structures or structures shorter than 18'-5"** – These structures are small structures where it is preferable to use traditional W-beam guardrail to protect the adjacent roadside hazard (typically fall off protection or protection from blunt concrete end walls). If the structure is deep enough, W-beam guardrail can be installed above the structure. If the structure is too shallow to allow for the installation of W-beam guardrail above the structure, then the structure could be spanned with a long-span guardrail system in accordance with MDOT SHA's Book of Standards – For Highway & Incidental Structures, Standard No. 605.26 entitled "Traffic Barrier W Beam Post Placement Details for Spanning 12'-2" to 18'-5" Openings".

Chapter 2 Design Considerations

This chapter is intended to provide guidance on several design considerations associated with the placement of bridge railing.

2.1 Bridge Users

When bridge railing is to be installed, the designer must consider the bridge rail users and their unique requirements and characteristics. For purposes of this manual, roadway users have been broken into three categories based on their unique design requirements and needs:

- **Vehicle Traffic** – this category includes all motorized vehicles. Vehicular traffic can be further broken down based upon the *AASHTO Manual for Assessing Safety Hardware* defined Test Level criterion.
- **Pedestrian Traffic** – this category includes all pedestrian users. It is also important to note that in accordance with the American's with Disabilities Act (ADA), any bridge that can be accessed by those with disabilities must be designed to meet current ADA requirements.
- **Bicycle Traffic** – this category includes all bicycle users.

2.2 Bridge Railing Applications

The Maryland Department of Transportation defines four different bridge rail applications based upon their installation configurations. The four different bridge rail applications that MDOT SHA recognizes are described below:

- **Traffic Railing** – A traffic railing is a bridge railing that has been designed and crash tested to withstand vehicular impact loading. This bridge railing type is to be used adjacent to vehicular traffic on bridges. The traffic rail that is selected shall be crashworthy for the design traffic which will utilize the facility.
- **Pedestrian Railing** – A pedestrian railing must be used adjacent to all pedestrian walkways on bridge structures. The pedestrian railing must meet the requirements contained in the *AASHTO LRFD Bridge Design Specifications* manual for both height and clear-opening criteria. The *AASHTO LRFD Bridge Design Specifications* manual requires that all pedestrian railing must be a minimum of 42" in height measured from the top of the walkway. The clear opening between horizontal and vertical members of the pedestrian bridge railing must be small enough to not allow a 6" diameter sphere to pass through the bottom 27" of the railing. Above this 27" height, the clear opening shall be small enough that it shall not allow an 8" diameter sphere to pass through the railing. A safety toe rail or curb should also be provided. Note, most pedestrian railings have not been crash tested and have not been designed to withstand vehicle impact loads.
- **Bicycle Railing** – A bicycle railing must be used on all bridges that are specifically designed to carry bicycle traffic and at locations where a significant portion of the traffic using the facility will be bicycle traffic. The height of the railing as well as the openings of the railing shall conform to the guidance provided in the **Pedestrian Railing** section. When deemed necessary, rubrails attached to the bicycle rail to prevent handle bar snagging may also be attached to the rail.
- **Combination Railing** – A combination railing is defined as a bridge railing which meets the requirements of both a traffic railing and either a pedestrian or bicycle railing. A combination rail is typically installed behind a raised curb and sidewalk. Combination rails installed behind a raised curb are only used on low-speed roadways which are defined as a roadway with either the higher of the design speed or the posted speed being 45 mph or below.

Figure 2-1 to Figure 2-3 visually describe the various configurations of bridge rail applications. MDOT SHA's standard bridge railing is documented in Chapter 3 of this manual.



Figure 2-1: Roadway with No Pedestrian Facilities

Figure 2-1 depicts traffic railing installed adjacent to vehicle traffic on a roadway where there are no pedestrian accommodations. The traffic railing should be selected based on the requirements contained in this section as well as Section 1.2 and Section 1.3.



Figure 2-2: Low-Speed Roadway with Pedestrian Facility

Figure 2-2 depicts bridge railing installed behind a raised curb on a low-speed roadway where there are pedestrian accommodations. The bridge railing that is installed must be a combination rail which acts as both a traffic railing and either a pedestrian or bicycle railing. The minimum offset distance of 5'-8" between the face of the curb and the railing face is a critical dimension and should not be violated. If this dimension must be violated, then proper justification must be provided to the Office of Structures for approval.



Figure 2-3: Pathway Designated for Non-Vehicular Traffic

Figure 2-3 depicts pedestrian or bicycle railing installed on a bridge where vehicular traffic is prohibited and therefore, traffic railing is not required.

2.3 Bridge Rail Ends

The end of a bridge rail adjacent to the traveled way presents a roadside hazard which must be made crashworthy in accordance with this manual as well as the guidance contained in the *AASHTO Roadside Design Guide*. Any bridge rail end location that deviates from the requirements of this manual must submit a proposed solution or mitigation to the Director of the Office of Structures for approval.

The most common and effective way to protect the end of a bridge rail is to connect the bridge rail to the adjacent barrier leading up to the structure. When the bridge rail is connected to an adjacent W-beam guardrail, it is essential to install a proper stiffness transition between the two systems as well as to transition the shape and size of the bridge rail to ensure crashworthiness of the system.

A stiffness transition is required to produce a gradual stiffening of the system to eliminate vehicular pocketing, snagging, or penetration. The bridge rail shape and size must also be transitioned to reduce any potential snag points or any abrupt changes in geometry which could affect the rail's crashworthiness.

Crash testing has shown that these transition locations are sensitive systems and therefore, when a crashworthy stiffness transition is required at the end of the bridge rail, the stiffness transition as well as the end post layout shall conform to the MDOT SHA standard for the bridge rail application. Chapter 3 of

this manual provides a description of the end posts as well as the stiffness transitions that shall be used on each bridge rail application.

A crashworthy stiffness transition shall be installed on all approach ends to the bridge rail and on the trail end of the bridge rail on all conventional undivided two-way roadways. The trail end stiffness transition should then connect to a crashworthy and appropriate end treatment. On divided one-way roadways, a stiffness transition to protect the trail end of the bridge rail is not required unless there are mitigating circumstances present.

For structures carrying two-way traffic with no traffic barrier on the approach roadway and aesthetics is of concern, consider tapering the end post barrier on all four ends, away from the highway until the offset is beyond the clear graded area where a traffic barrier would no longer be warranted based on the flare rate requirements of the *AASHTO Roadside Design Guide*. This application is shown below as Figure 2-4. If aesthetics is not a main feature of the bridge, the appropriate stiffness transitions noted above and end treatments shall be included on all four ends.

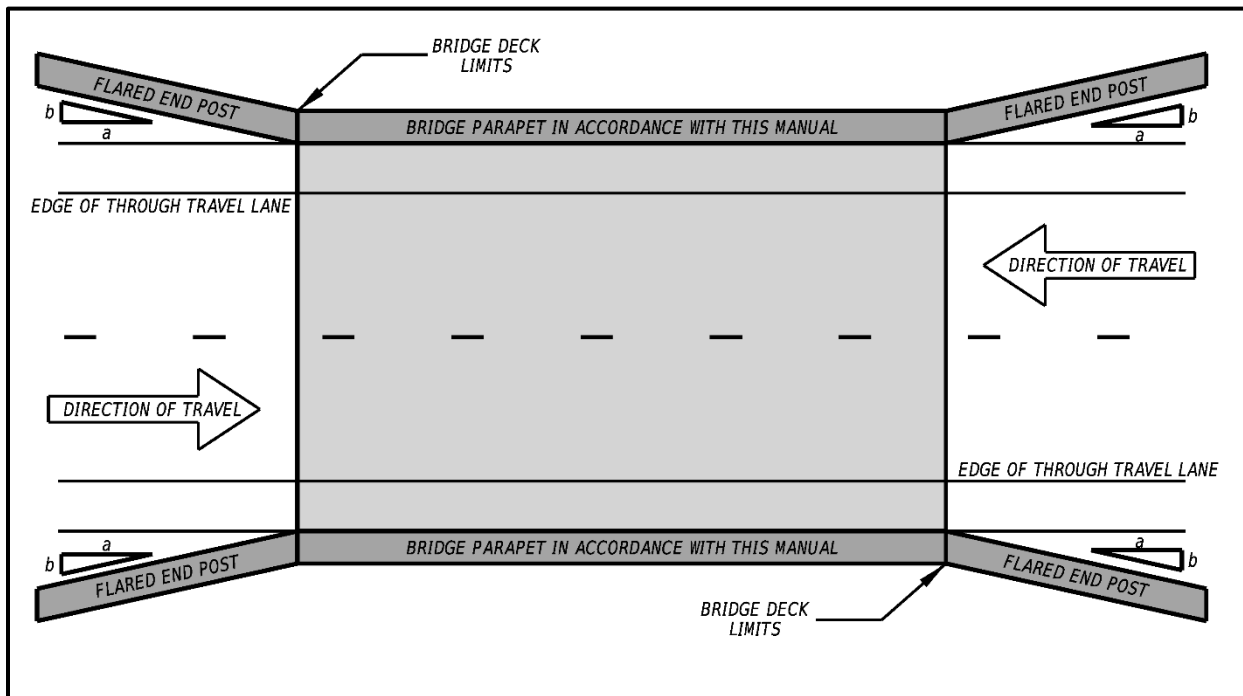

Figure 2-4: Tapered End Posts at Locations where Aesthetics is a concern and there is no Adjacent Guardrail

At location where sidewalk is installed adjacent to an end post, consideration must be given to the treatment of the sidewalk and end post. Where there is adjacent W-beam guardrail, maintain the sidewalk width with no offset between the sidewalks and curb for 25' minimum beyond end of end post. Where there is no traffic barrier on the adjacent highway, an option when right-of-way is available is to taper the parapet away from the highway (25' minimum taper length) until the offset is 10' minimum on approach and trailends.

2.4 Fencing

Fencing or protective screenings should be placed on top of certain structures to prevent individuals from throwing debris from the structure. Maryland State Highway Administration maintains details for attaching fencing to bridge railing in Chapter 3, Section 4 of MDOT SHA's Book of Details – For Highway & Incidental Structures. Fencing shall be added to structures in accordance with Section 2.4.1 of this manual. Fence posts shall be spaced in accordance with Section 2.4.2 of this manual.

2.4.1 Fencing Locations

Fencing can affect a system's performance and crashworthiness and should only be placed where absolutely needed. Fencing or protective screening shall be added to structures in accordance with Figure 2-5. Use anti-climb shields at locations as needed.

Fencing Application	MDOT SHA Guidance
Bridges over Roadways and/or Pedestrian Facilities	A bridge shall contain fencing when there is a roadway or pedestrian facility underneath. If the bridge is on a controlled access highway then no fencing is required, unless there is a history of problems with 'overhead bombing' (items being thrown from the structure) or where the potential of 'overhead bombing' exists.
Bridges over Railroads	<p>Bridges over electrified railroads shall have protective barrier on spans over railroad and vertical safety fencing on each adjacent approach span. If the remainder of the bridge requires less than 100 ft. of additional fencing per side, then the entire bridge shall have fence</p> <p>Bridges over non-electrified railroads which consist of only a main span and two flanking spans shall have the entire bridge fenced. All other bridges in this category shall have only the span over the railroad fenced; however, if the bridge is on a controlled access highway then no fencing is required.</p>
Bridges over Environmental Features (streams, rivers, wetlands, etc.)	Bridges over environmental features do not require fencing unless there are known problems of 'overhead bombing' (items being thrown from the structure) or where the potential of 'overhead bombing' exists. Consideration should be given to the land use below the structure (i.e. parkland, marina, etc.)
Retaining walls, culvert wing walls, headwalls and roadway barrier adjacent to structures	<p>The proposed locations for these structures shall be evaluated for potential safety problems. Consideration should be given to the proximity of the structure to dwellings, schools, businesses, etc; the possibility of access to the structure; the proximity of right-of-way or other fencing, barriers, etc.; as well as any other factors which may apply.</p> <p>If fencing is warranted, a type of fence shall be selected which will be consistent in appearance to other features in the immediate vicinity. Also, consideration should be given to the height of the fence (three foot minimum).</p>

Figure 2-5: Fencing Attachment Guidance

2.4.2 Fence Post Spacing

The fence post spacing on a bridge rail shall be in accordance with this manual. The following guidelines for post spacing are provided and illustrated in Figure 2-6:

- All post spacings shall be equal on each individual span.
- Fence shall be continuous across all supports.
- Fence post spacing should range from 6'-0" minimum to 8'-0". Effort should also be made to make spacing of posts for all spans nearly as equal as possible.
- The fence post spacing over the bridge joint shall be equal to the average spacing of the flanking span.
- Fence shall extend onto bridge wing walls and retaining walls until the potential drop from the top of barrier to the ground below is 8'-0" or less.

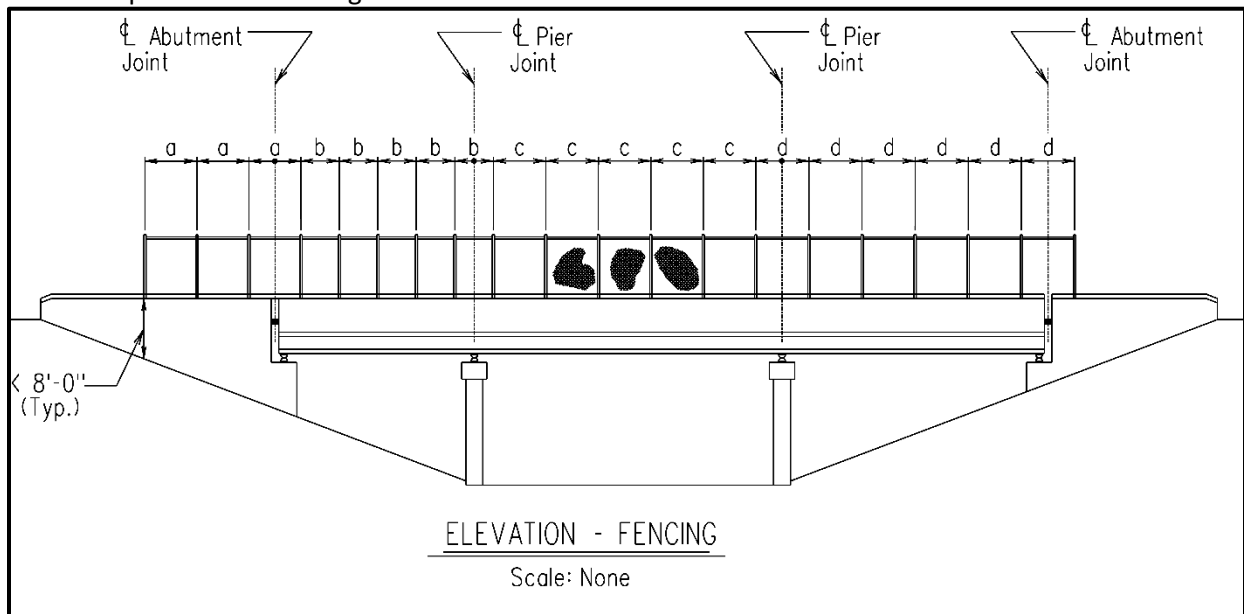

Figure 2-6: Fence Spacing on Bridges

2.5 Bridge Rails on Retaining Walls

Roadways that are elevated on retaining wall structures require the use of longitudinal barrier in accordance with the *AASHTO Roadside Design Guide*. The longitudinal barrier that is installed shall be a standard MDOT SHA approved bridge rail. MDOT SHA's standard bridge rails are included in this manual in Chapter 3. When a reinforced concrete TL-5 bridge rail is used on top of a reinforced concrete retaining wall, the bridge rail shall be doweled into the retaining wall as shown in Figure 2-7 below. If bridge rail is used on top of other retaining walls (MSE, post and plank, etc.), the bridge rail shall be doweled into a moment slab atop the wall in accordance with Figure 2-8. The reinforced concrete retaining wall and/or moment slab shall be properly designed for all loads in accordance with the governing AASHTO LRFD Bridge Design Specifications.

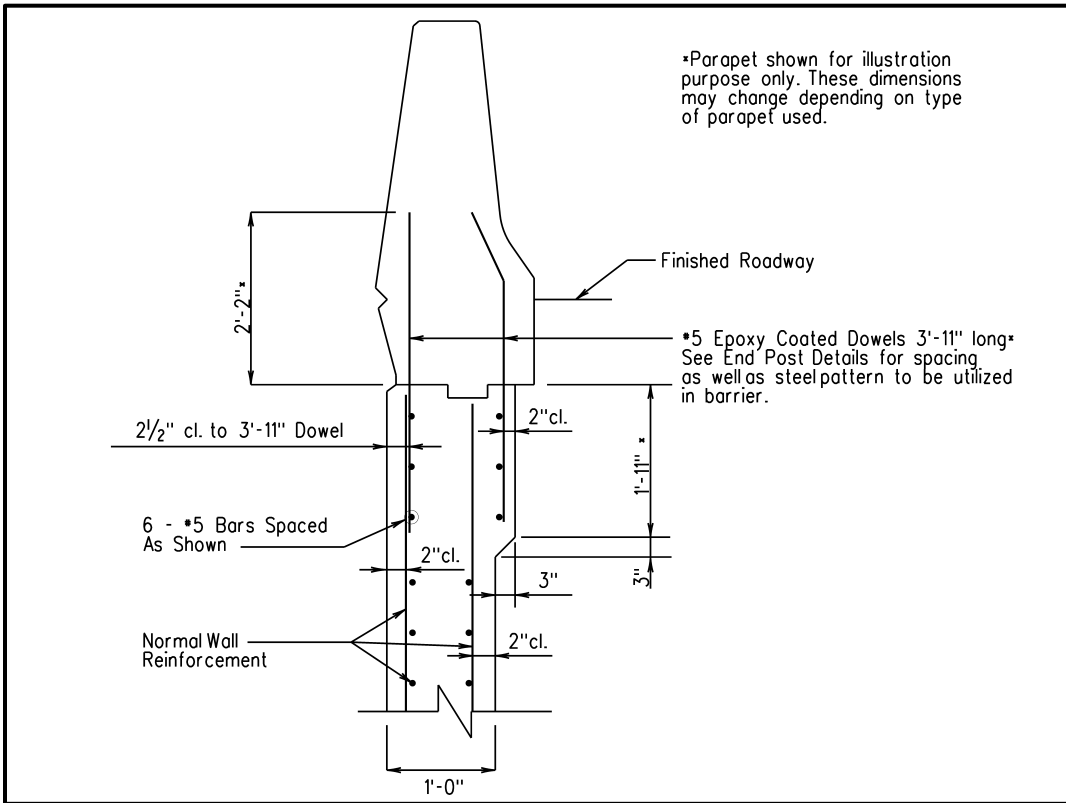

Figure 2-7: Parapet Attachment for Walls with 1'-0" Stem Thickness

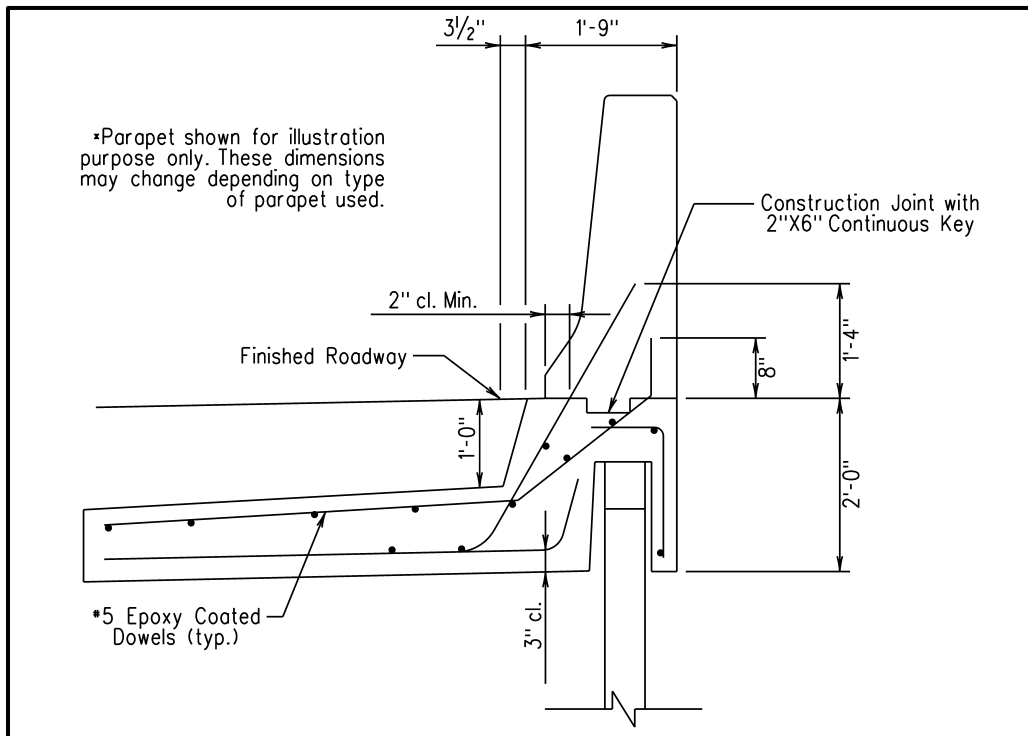

Figure 2-8: Barrier Doweled into Moment Slab

2.6 Bridge Rail Selection Coordination

Bridge rail selection should be coordinated closely with certain MDOT SHA sections for particular applications. Below is a list of applications which require close coordination with MDOT SHA sections:

- Structures that are on scenic byways or that are over an environmental feature will require both internal and external stakeholder coordination in the selection of an appropriate crash tested parapet or railing.
- If the roadway approaches do not have sidewalks, and the bridge is located within 1 mile of a school, park or playground, or is located within 1/2 mile of a developed area (residential or commercial), the bridge is a candidate for 5'-8" sidewalks and should be coordinated with both internal and external stakeholders. A developed area would consist of several homes grouped together along a section of highway, whereas a non-developed area could consist of woods or fields alongside of the road with only a few scattered homes set back from the edge of road. The Office of Planning and Preliminary Engineering (OPPE) should be contacted to determine if there are any future improvements planned for this area that would require widening the bridge.

2.7 Existing Structures

Consideration should be given to upgrading the existing parapet to a crash tested barrier alternative during bridge rehabilitations. Parapet upgrades should be considered on a case by case basis; however, several general guidelines are provided below:

- All bridge re-decking rehabilitations should replace the existing parapet to conform to the requirements of this manual.
- When an overlay is to be performed, the existing parapet should be evaluated based on the existing parapet condition, accident history at the location, construction cost as well as roadway classification and volume.
- In all cases, parapet upgrades should be commensurate with the scope of the rehabilitation.

Chapter 3 Bridge Rail Selection

This chapter documents MDOT SHA's standard bridge railings as well as provides application guidance for each standard bridge rail. Standard MDOT SHA bridge railing should be the first bridge railings considered; however, in some instances a non-standard application may be required based on the unique challenges of a location. Section 3.2 of this chapter documents the process that must be followed when a bridge railing other than an MDOT SHA standard bridge railing is proposed for use.

3.1 MDOT SHA Standard Bridge Rails

The Maryland Department of Transportation – State Highway Administration (MDOT SHA) Office of Structures currently maintains details of bridge rails. Below is a discussion of each MDOT SHA bridge rail detail.



42" F-Shape Parapet (SUP-TB(42F))	
Section 2.2 Classification:	Traffic Barrier
MASH Test Level Approval:	TL-5
Suggested Application Locations:	<p>This traffic barrier is generally the default barrier for MDOT SHA structure use. It shall be used provided the following conditions are met:</p> <ul style="list-style-type: none"> • No sidewalks; • Not a single slope barrier application location (see single slope barrier suggested application locations; and • Not a tube rail barrier application location (see tube rail barrier suggested application locations).
Height Requirements:	The barrier must be 42" for MASH TL-5 compliance. The 3" toe allows for future overlays, however, with any decrease in height, the barrier is considered a TL-4 application and not a TL-5 application.
Transition Requirements:	This application requires an end post in accordance with MDOT SHA SUB-EP(42F) and a full stiffness transition in accordance with MD 605.41.



Single Slope Parapet (SUP-TB(SS))	
Section 2.2 Classification:	Traffic Barrier
MASH Test Level Approval:	TL-5
Suggested Application Locations:	<ul style="list-style-type: none"> • Interstates; • Interstate ramps; and • Highways with more than two travel lanes in a given travel direction (excluding acceleration/ deceleration lanes) with a posted speed greater than or equal to 50 mph.
Height Requirements:	The barrier must be 42" for MASH TL-5 compliance. The single slope face allows for future overlays, however, with any decrease in height, the barrier is considered a TL-4 application.
Transition Requirements:	This application requires an end post in accordance with MDOT SHA SUB-EP(42SS) and a full stiffness transition in accordance with 605.41.



Parapet with Sidewalk (SUP-TB(SW))	
Section 2.2 Classification:	Combination Barrier
MASH Test Level Approval:	TL-2
Suggested Application Locations:	<p>The Parapet with Sidewalk barrier should only be used at low-speed locations where pedestrian facilities are present and where the posted speed is 45 mph or less.</p> <p>This bridge rail meets all the requirements to be considered a pedestrian railing and/ or a bicycle railing.</p> <p>The sidewalk width should be installed at a minimum of 5'-8" in width.</p>
Height Requirements:	The barrier must be 42" in height to be considered acceptable as a pedestrian or bicycle rail.
Transition Requirements:	This application requires an end post in accordance with MDOT SHA SUB-EP(SW)-101 and a full stiffness transition in accordance with 605.41.



Tube Rail Parapet (SUP-TB(TR))	
Section 2.2 Classification:	Traffic Barrier
MASH Test Level Approval:	TL-4
Suggested Application Locations:	<ul style="list-style-type: none"> • Locations, other than Interstates, where accelerated bridge construction techniques preclude the use of a concrete barrier. • Low-speed locations where an open rail is desired for viewing scenic vistas and bridge length is generally less than 200 ft. A low-speed roadway is defined as any roadway where the posted speed is less than 50 mph. <p>Exceptions to the above must be approved by the Director of the Office of Structures.</p>
Height Requirements:	No overlays shall occur in front of this rail that would reduce the height of the curb to less than 7".
Transition Requirements:	This application requires a bridge rail end and a stiffness transition consistent with MDOT SHA's drawing SUP-TB(TR)-102.



Thrie Beam Attached to Vertical Wall (SUP-TB(34T))	
Section 2.2 Classification:	Traffic Barrier
MASH Test Level Approval:	TL-3
Suggested Application Locations:	This traffic barrier should be used on roadways with very low mixtures of heavy vehicles and where the distance between the normal termination point of thrie beam on the approach and trail ends is between 18'-6" to 40'-0".
Height Requirements:	Future overlays in front of this application are acceptable. The barrier must maintain a 29" height in order to be considered MASH TL-3 compliant.
Transition Requirements:	A full stiffness transition in accordance with MD 605.41-01.

3.2 Use of Non-Standard MDOT SHA Bridge Rails

Bridge railing other than the bridge rails presented in this chapter are acceptable on Maryland Roadways with the approval of MDOT SHA's Office of Structures. Bridge rails that are submitted to the Office of Structures for consideration for use on a project should consider the following items in their submittal:

- Describe the conditions that are present which prohibit a standard bridge rail from being used.
- Describe whether the proposed bridge rail has been successfully crash tested under MASH crash test criteria.
- Describe whether the bridge rail has been approved for specific uses by the FHWA and whether this approval was based on full-scale crash testing or upon other methods.
- If full-scale crash testing or FHWA approval has not been issued, please describe what previous analysis has been performed to justify its use.
- Provide any other relevant justification or reasoning for the proposed bridge rail's use.

Chapter 4 Temporary Barriers

All temporary barrier that is installed during construction must be crashworthy during all phases based upon the criteria presented in the *AASHTO Manual for Assessing Safety Hardware*.

4.1 Design Considerations

In addition to passing all necessary crash testing evaluation criteria, another key element to consider when prescribing temporary barrier as a positive work zone protection device is the associated deflection of the barrier when the system is struck. The distance the barrier will slide when impacted is a function of the vehicle speed as well as the characteristics of the temporary barrier which is struck.

There are three primary measurements for barrier deflection which are defined below:

- **Dynamic Deflection** – the maximum amount that a point on the barrier system translates at any time during an impact.
- **Permanent Set** – the maximum amount that one point translates on the barrier and then sets to its final position.
- **Working Width** – The maximum post-crash lateral deflection measured from the barrier face prior to the crash to any part of a barrier system or vehicle post-crash.

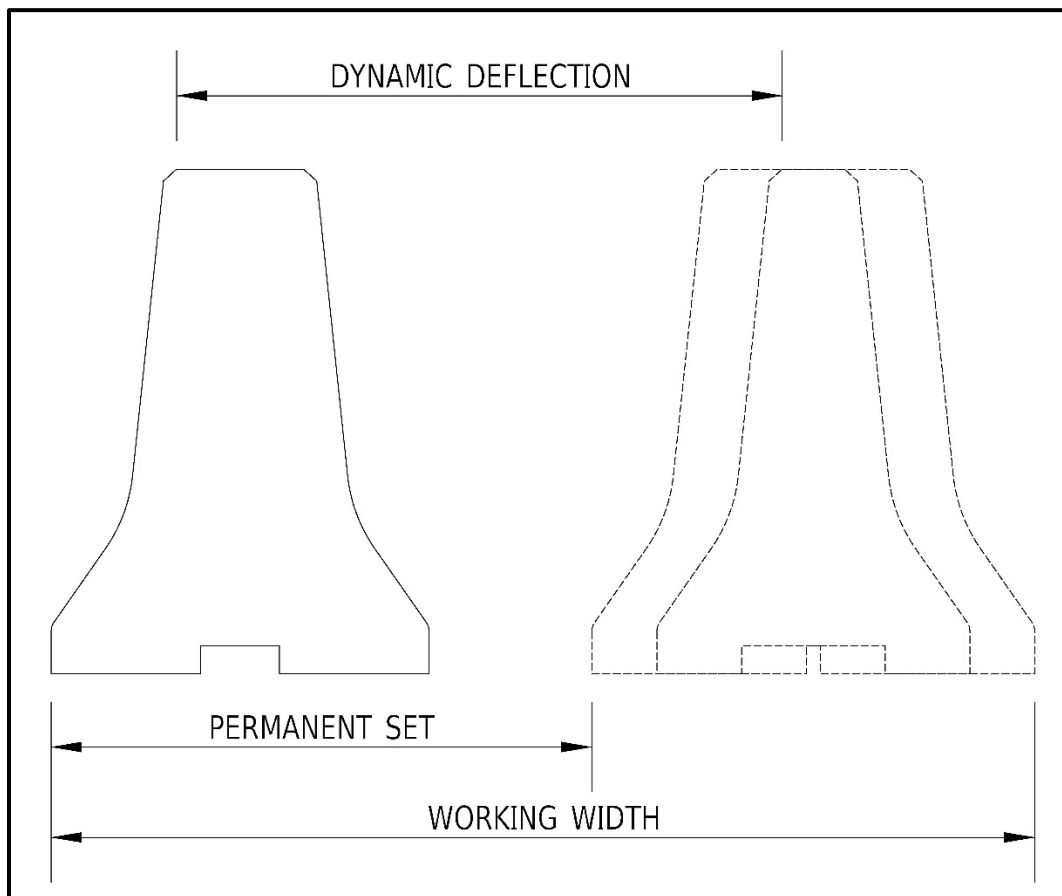

Figure 4-1: Barrier Deflection

Temporary barrier can be either anchored or unanchored to the roadway. Anchored barrier deflects less than unanchored barrier; however, it is more costly and typically requires intrusive anchors or pins to be installed into the underlying pavement. In addition, crash-test performance is considerably better for the vehicle and the occupant with unanchored barrier.

Temporary barriers are crash tested to the same Test Levels that were presented in Section 1.2 of this manual. Based on their temporary nature, work zone devices are typically tested to withstand TL-3 prescribed forces. As such, it is MDOT SHA’s practice to consider Test Level 3 forces when accounting for the deflection of temporary barrier into the work zone. Figure 4-2 captures the amount of buffer space that MDOT SHA prefers behind barrier to the active work zone.

Roadway Surface	Temporary Barrier Treatment	Deflection Space Provided behind Temporary Barrier (ft)
Portland Cement Concrete	Unanchored	5' *
	Anchored	1' **
Bituminous Concrete	Unanchored	5' *
	Anchored	1.5'

Figure 4-2: Work Zone Buffer Space

- * It should be noted that the 5’ buffer space prescribed for unanchored temporary barrier in Figure 4-2, is based upon the deflection of the non-proprietary pin and loop connection.
- ** 12” deflection behind the Portland Cement Concrete anchored temporary barrier is based on MDOT SHA’s observation of historical performance.

The leading end of temporary barrier runs shall also be protected. In general, there are four ways to protect temporary barrier end segments:

- **Connect to an existing shielding system** – This is MDOT SHA’s preferred practice when there is permanent barrier in the vicinity of the temporary installation. A stiffness transition must be used to connect the temporary barrier to permanent barrier installations. There have been several systems developed and tested for MASH compliance that connect portable concrete barrier to W-beam guardrail, reduced deflection portable concrete barrier, and permanent concrete barrier.
- **Overlap the temporary barrier behind a permanent shielding system** – This method is not preferred but is acceptable on a case by case basis. In this option, the temporary barrier system is designed to overlap with a permanent installation. In these cases, the dynamic deflection and the beginning length of need points of the permanent and temporary barrier system must be considered when prescribing an overlap distance and offset.
- **Install an appropriate End Treatment (Terminals, Crash Cushions)** – Where there is no permanent barrier in the vicinity or a connection cannot be made to a permanent system, a MASH compliant end treatment can be prescribed from Maryland’s Qualified Products List.
- **Flare outside the Clear Zone** –The end treatment may be omitted in cases where the temporary barrier can be flared an appropriate distance outside of the clear zone. Flare rates should be in accordance with the current edition of the AASHTO *Roadside Design Guide*.

4.2 MDOT SHA Standard Low Deflection Applications

In addition to freestanding temporary barrier, The Maryland Department of Transportation – State Highway Administration (MDOT SHA) Office of Structures currently maintains details of low deflection temporary barrier applications. Below is a discussion of each MDOT SHA low deflection temporary barrier detail.

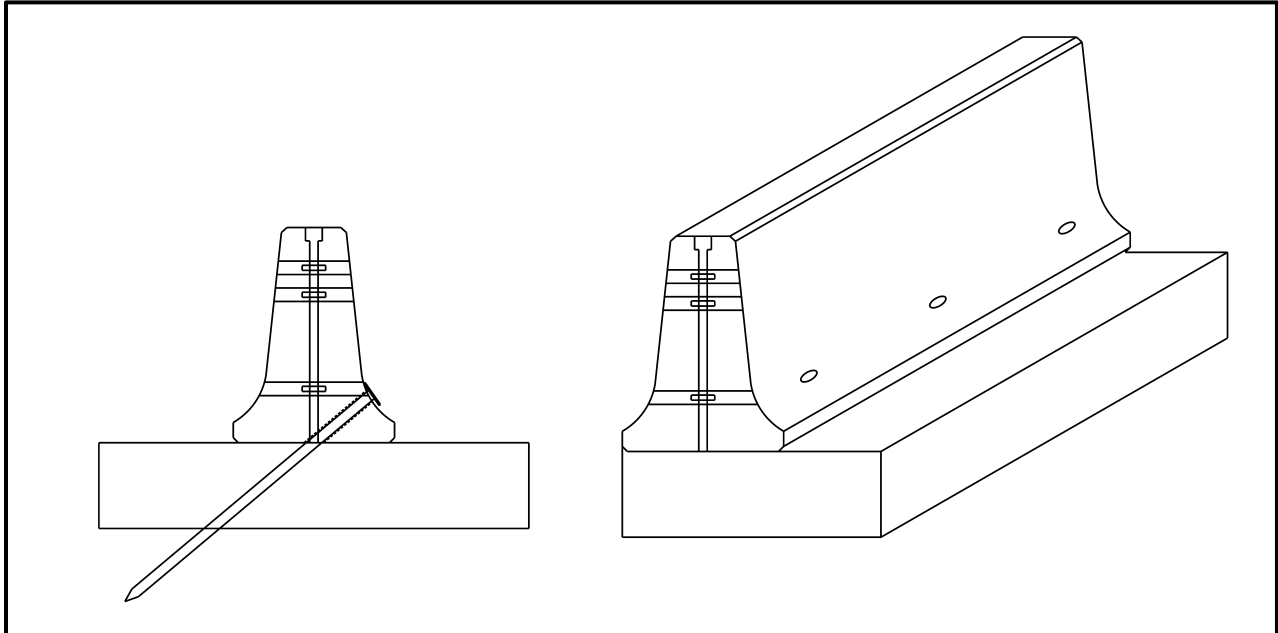

Low Deflection Pinned to Asphalt (MOT-XXX)	
Application Locations:	This application is intended to be used on asphalt pavement surfaces and adjacent to constrained work zones. The asphalt pavement must be at least 4" in depth in order to function as intended.
MASH Test Level Approval:	TL-3
System Components:	<p>The system consists of the following components:</p> <ul style="list-style-type: none"> • The barrier segments are 12'-6" long and have three anchors per barrier segment. • The temporary barrier segments are connected with a pin and loop connection. • The barrier segments are 24" wide. • The system is anchored to the road with 48" long pins anchored at a 40° angle relative to the road surface. This pin extends approximately 18" behind the back toe of the barrier into the work zone.
System Deflection:	<p>The tested dynamic deflection was as follows:</p> <ul style="list-style-type: none"> • Permanent Set: 17.0" • Dynamic Deflection: 17.8" • Working Width: 29.9"
MDOT SHA Required Offset to Work Zone:	18" measured from the back toe of the barrier.

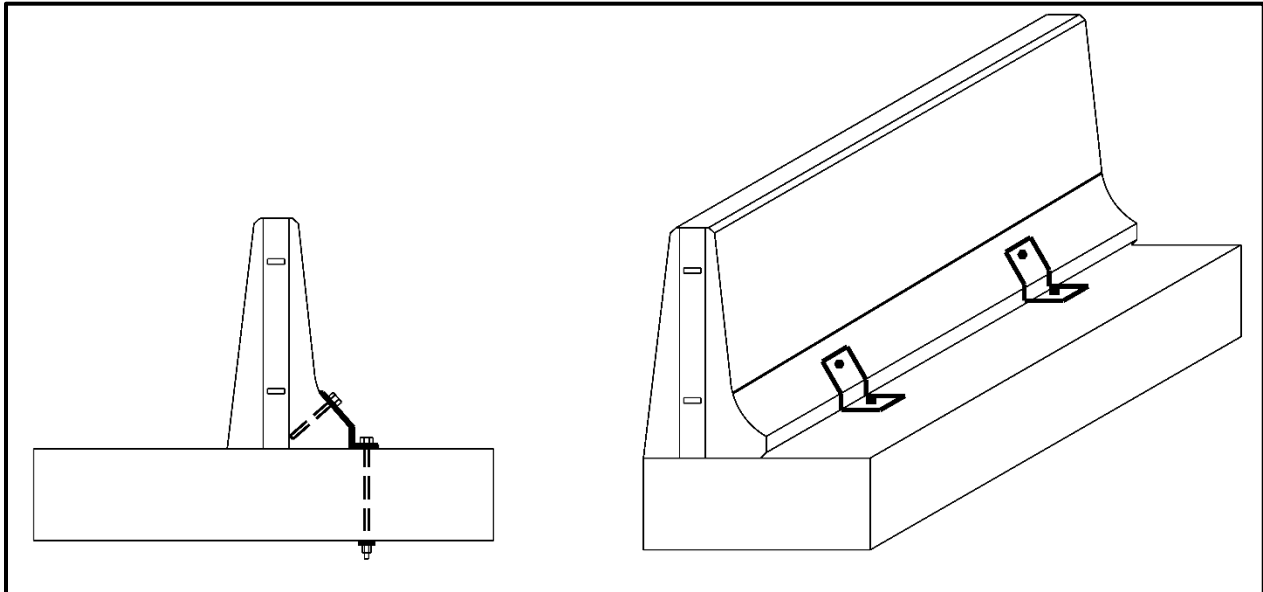

Low Deflection Pinned to Concrete Bridge Deck (MOT-101)	
Application Locations:	This application is intended to be used on concrete pavement surfaces or bridge decks adjacent to constrained work zones.
MASH Test Level Approval:	TL-3 (Based on past performance for MDOT SHA. Crash testing to be performed.)
System Components:	<p>The system consists of the following components:</p> <ul style="list-style-type: none"> • The barrier segments are 12'-0" long and have two anchors per barrier segment. • The temporary barrier segments are connected with a pin and loop connection. • The single face barrier segments are 17" wide while the double face barrier segments are 24" wide. • An angle is welded to a plate which is fit around the toe of the barrier and the road surface. A bolt is anchored into the barrier segment as well as bolted through the road.
System Deflection:	Unknown. This system has not been crashed test for MASH compliance to date. Based on past performance, it is assumed the system will deflect 12" during an impact.
MDOT SHA Required Offset to Work Zone:	12" measured from the back toe of the barrier.